

BAR STOOL
TABOURET DE BAR
TABURETE DE BARRA

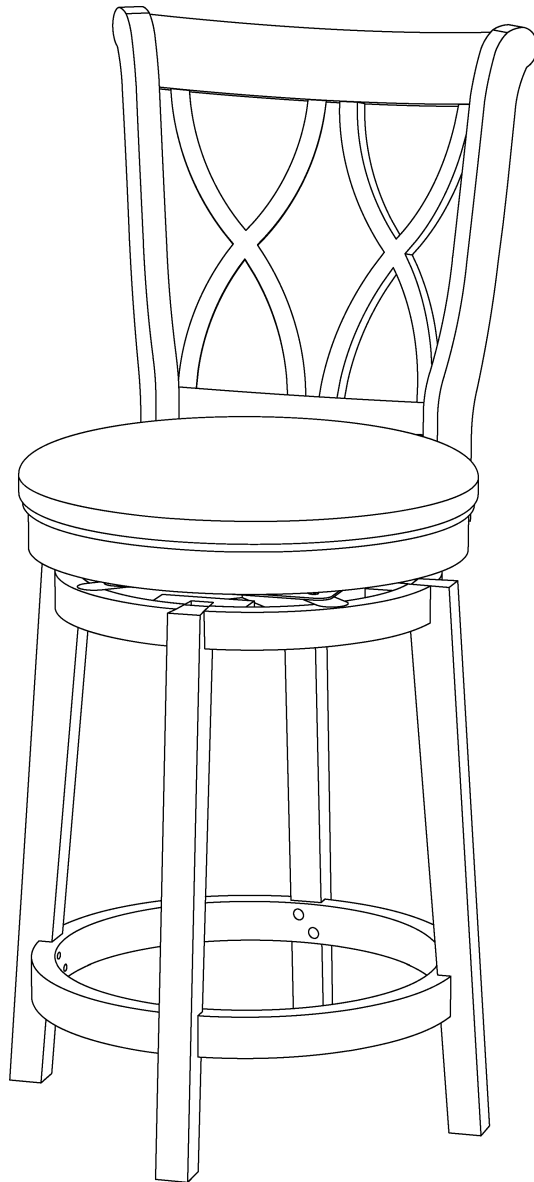

We are here to help!
Before you return it - contact us.

We do our best to insure that your furniture arrives in excellent condition.

If you need assistance with assembly or replacement parts, please call Customer Service, prior to returning the item to the store.

Nous sommes là pour vous aider!
Avant de retourner le produit, veuillez communiquer avec nous.

Nous faisons tout en notre pouvoir pour que vous receviez votre meuble en parfait état.

Si vous avez besoin d'une pièce de rechange ou d'aide pour l'assemblage, veuillez communiquer avec le Service à la clientèle avant de retourner le produit au magasin.

¡Estamos aquí para ayudarle!
Antes de regresar el producto, comuníquese con nosotros.

Hacemos todo lo posible para que su mobiliario se le entregue en excelentes condiciones.

Si necesita ayuda para ensamblar su producto o para obtener piezas de repuesto, llame al Servicio al Clienten antes de devolver el artículo a la tienda.

HARDWARE LIST

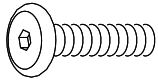

H1 x 04
Ø 1/4"x1-3/16"

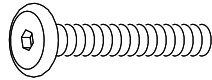

H2 x 12
Ø 1/4"x1-3/4"

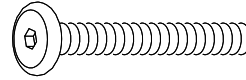

H3 x 04
Ø1/4"x2-3/16"

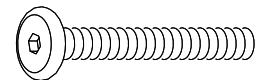

H4 x 04
Ø1/4"x2-3/8"



H5 x 24
Ø1/4"

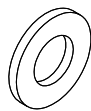

H6 x 24
Ø1/4"x1.5mm

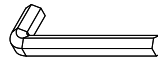

H7 x 01
4mm

PART LIST

PARTS	DESCRIPTION	QTY
A	CHAIR BACK	01
B	CUSHION SEAT WITH FRAME	01
C	UPPER RING W/10" SWIVEL	01
D	CHAIR LEG	04
E	LOWER RING	01

IMPORTANT:

1. Do not tighten bolts completely until all bolts are completely lined up and inserted into holes / nuts.
2. Do not over tighten screws and bolts to avoid stripping.
3. Please use hand tools to assemble this product. Do not use power tools.

IMPORTANT:

1. Ne serrez pas complètement les boulons jusqu'à ce qu'ils soient bien alignés et insérés dans les trous et les écrous.
2. Ne serrez pas excessivement les boulons pour éviter d'endommager les filets.
3. veuillez utiliser des outils manuels pour assembler ce produit. Ne pas utiliser d'outils électriques.



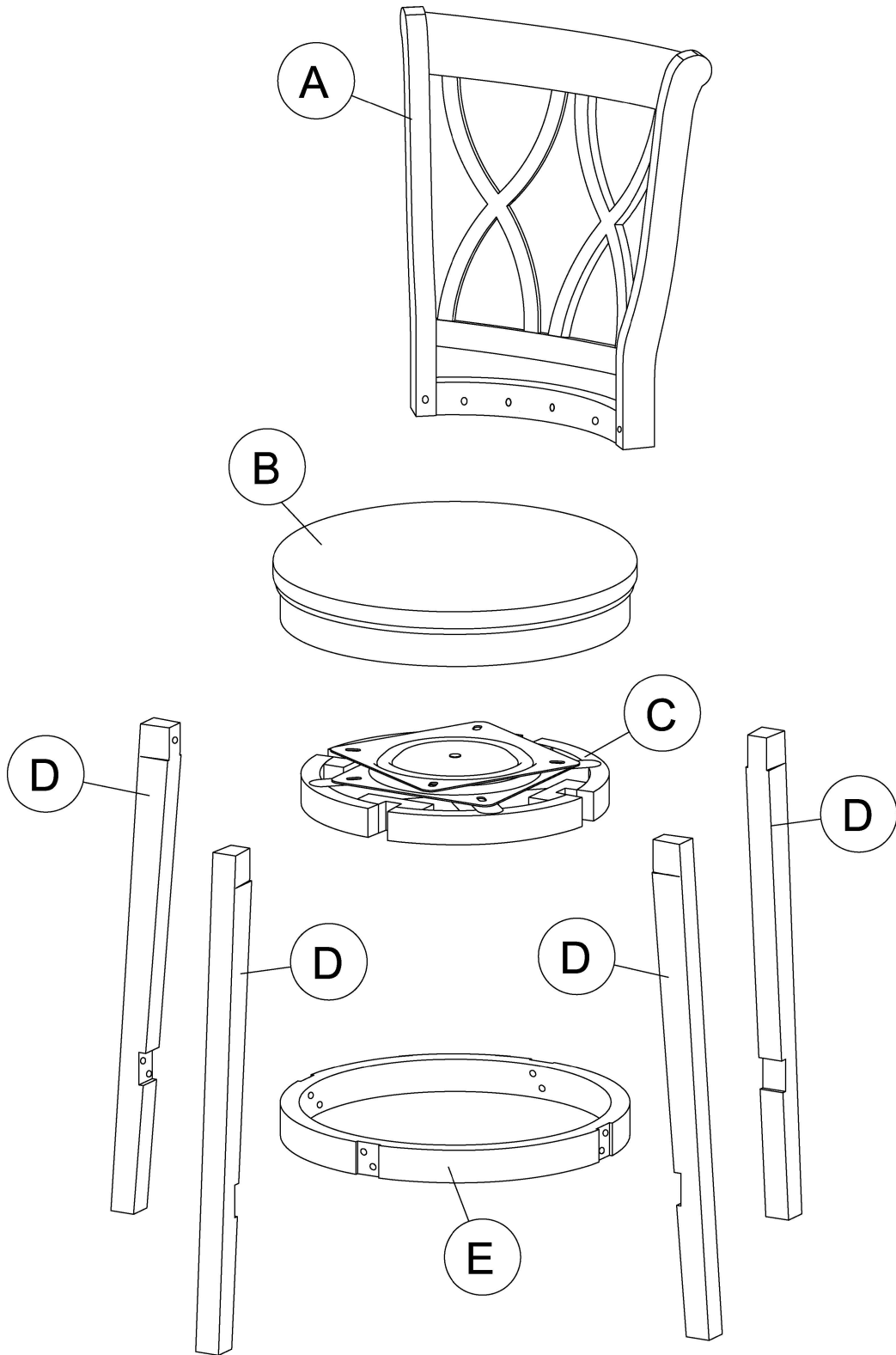

IMPORTANTE:

1. No apriete completamente los pernos hasta que estén bien alineados e insertados en los orificios y las tuercas.
2. No apriete exageradamente los pernos para evitar dañar las roscas.
3. Favor de utilizar herramientas manuales para ensamblar este producto. No utilizar herramientas eléctricas.

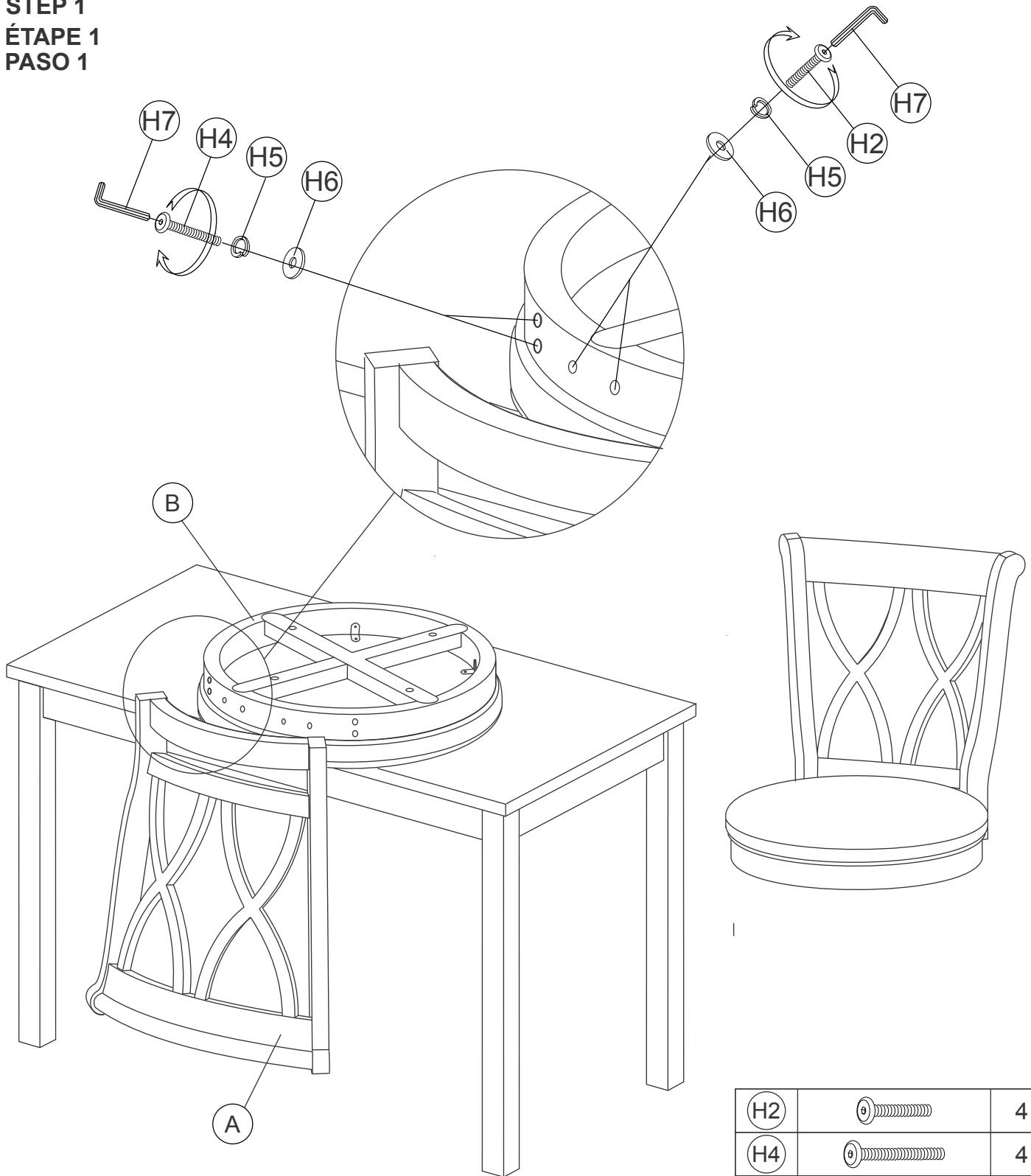

STEP 1
ÉTAPE 1
PASO 1



H2		4
H4		4
H5		8
H6		8
H7		1

STEP 2
ÉTAPE 2
PASO 2

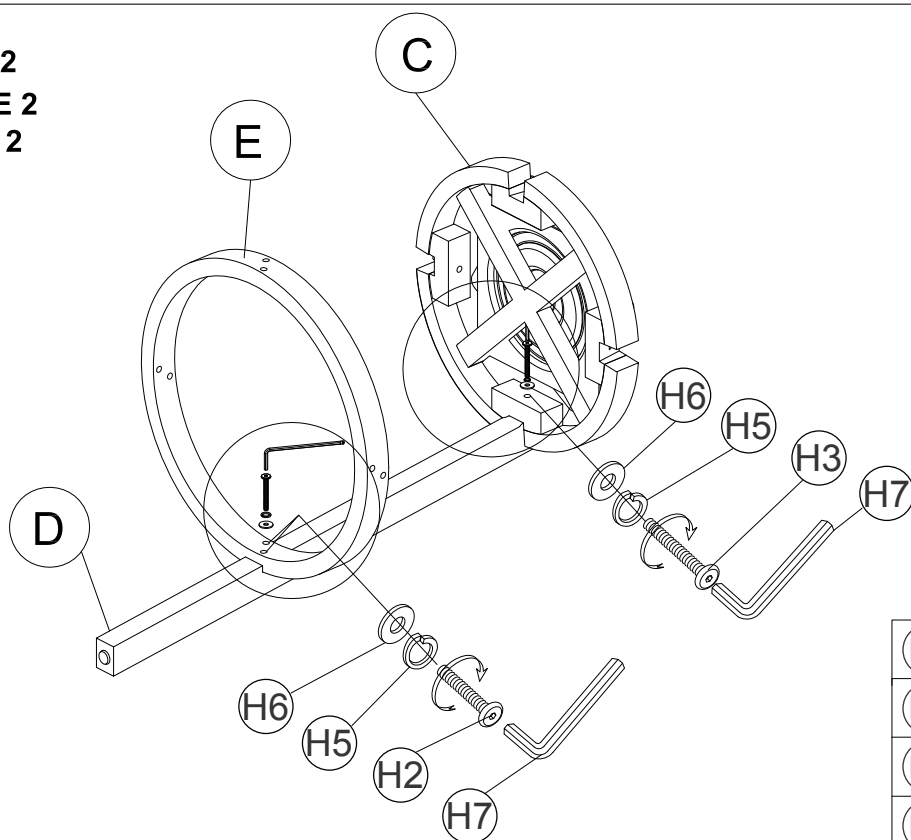

H2		2
H3		1
H5		3
H6		3
H7		1

STEP 3
ÉTAPE 3
PASO 3

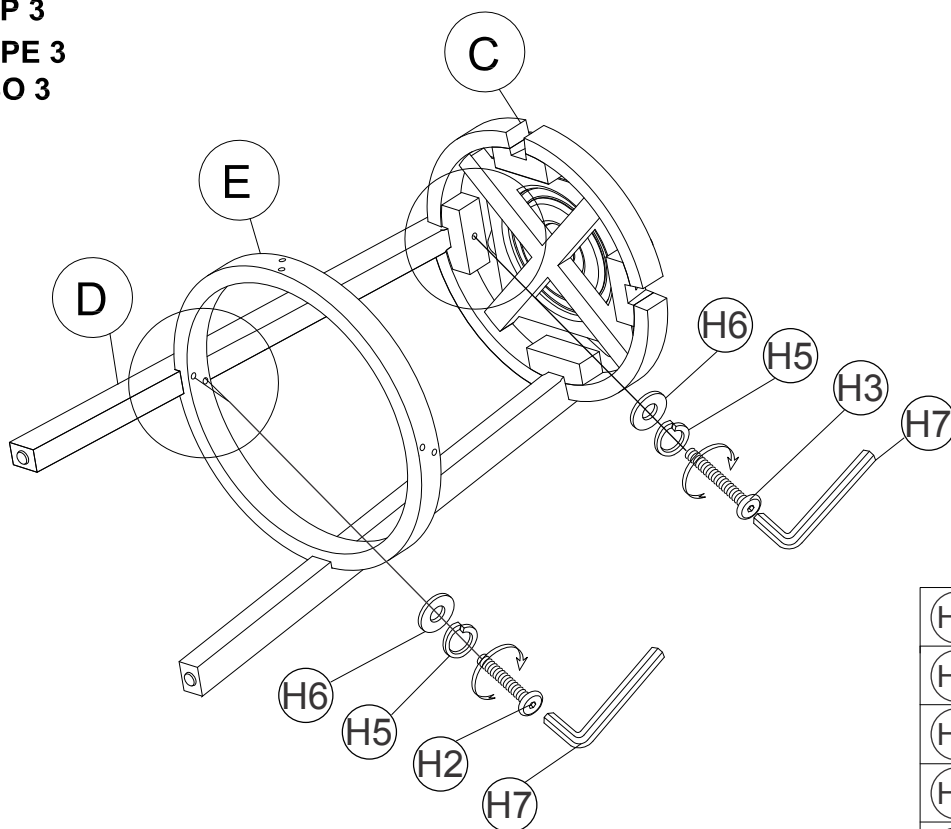

H2		2
H3		1
H5		3
H6		3
H7		1

STEP 4
ÉTAPE 4
PASO 4

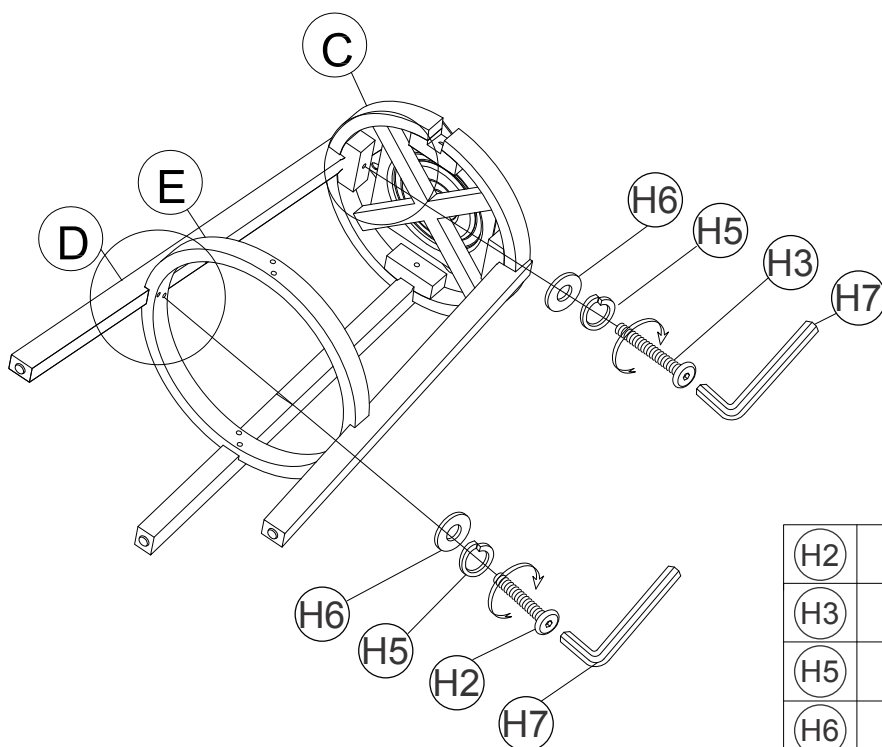

H2		2
H3		1
H5		3
H6		3
H7		1



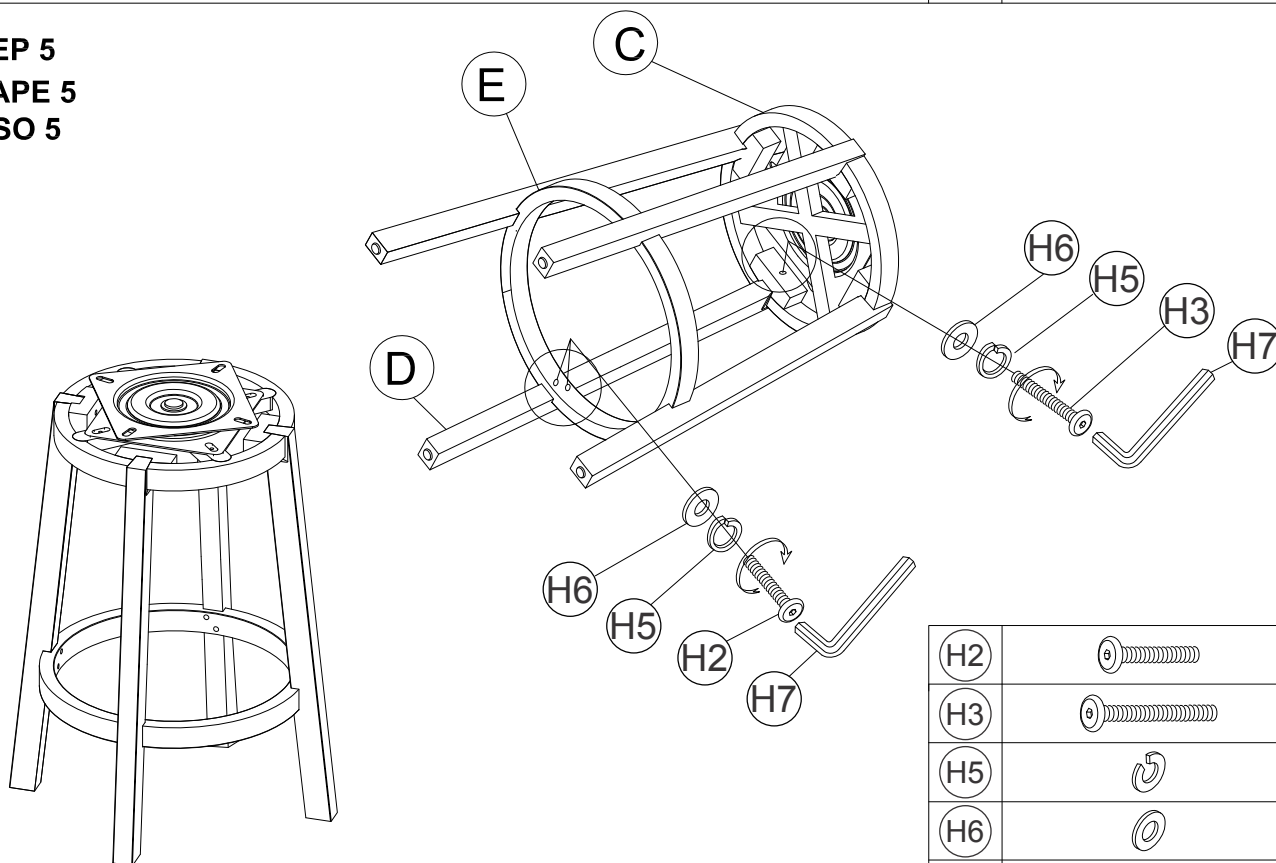

STEP 5
ÉTAPE 5
PASO 5

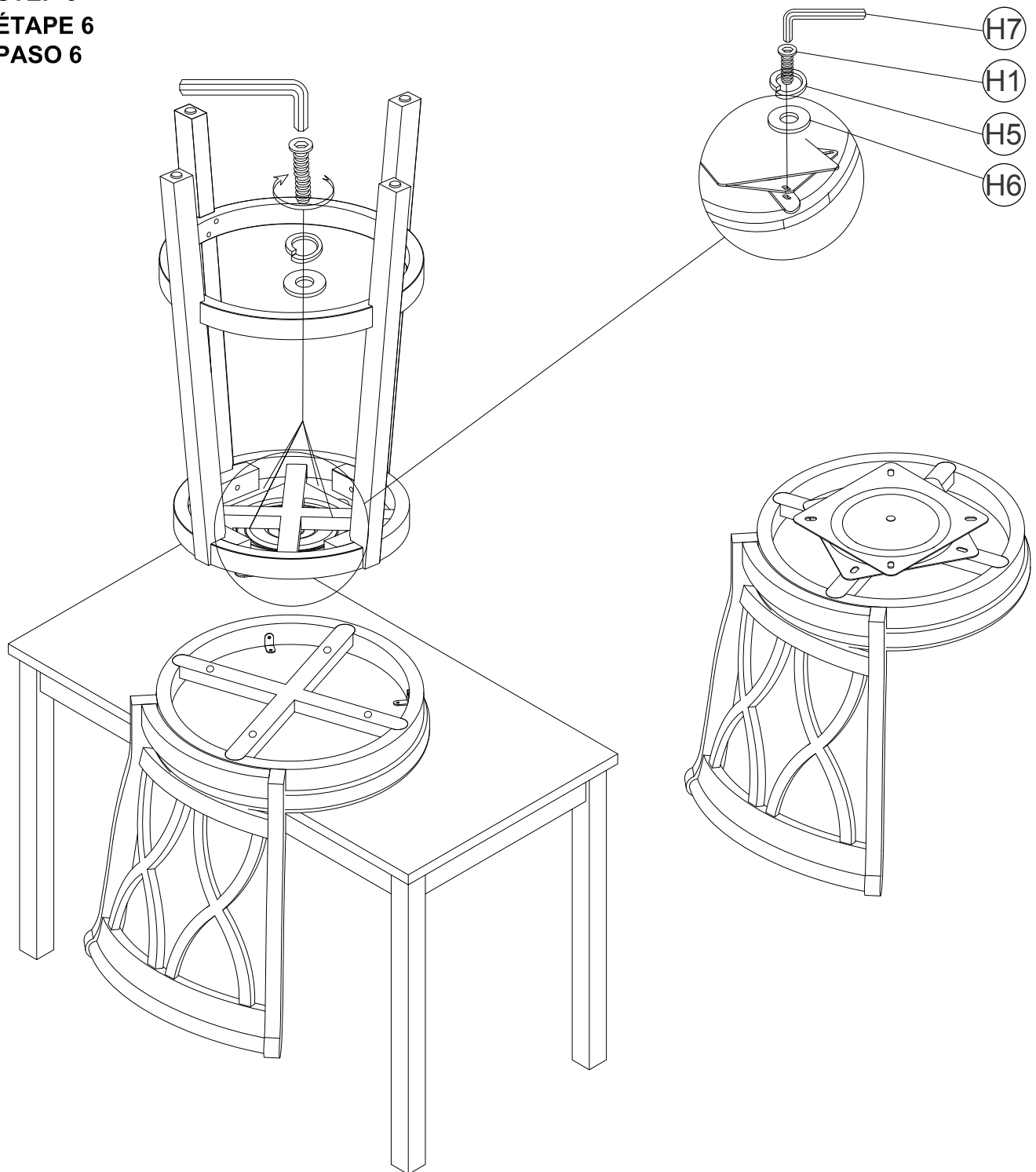

H2		2
H3		1
H5		3
H6		3
H7		1

STEP 6
ÉTAPE 6
PASO 6



(H1)		4
(H5)		4
(H6)		4
(H7)		1

STEP 7
ÉTAPE 7
PASO 7

WEIGHT LIMIT 275 LBS
POIDS MAXIMAL 275 LBS
LÍMITE DE PESO 275 LBS

