

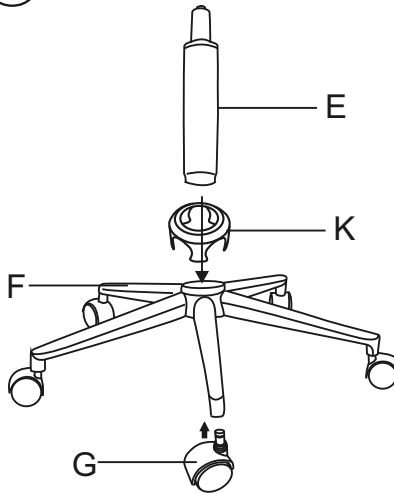

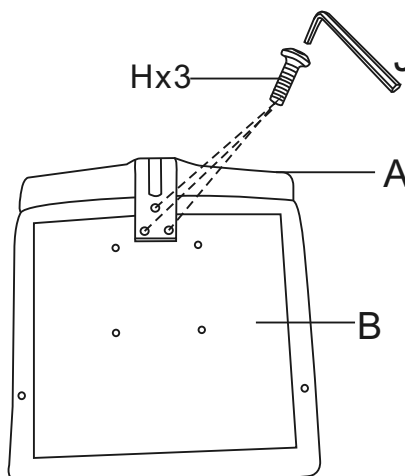

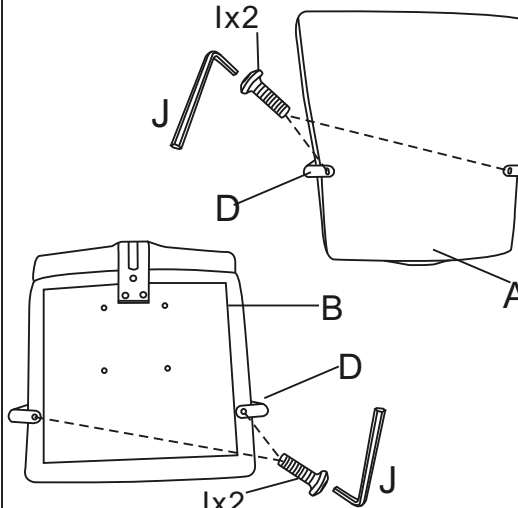

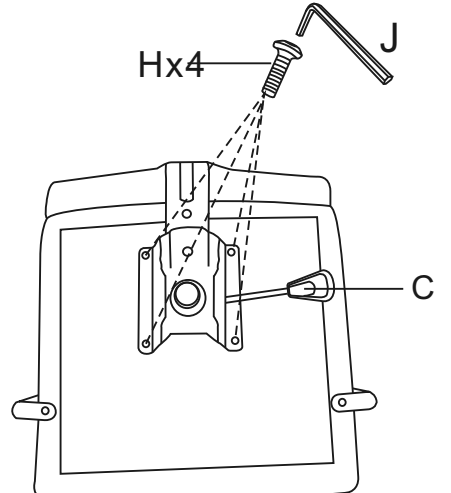

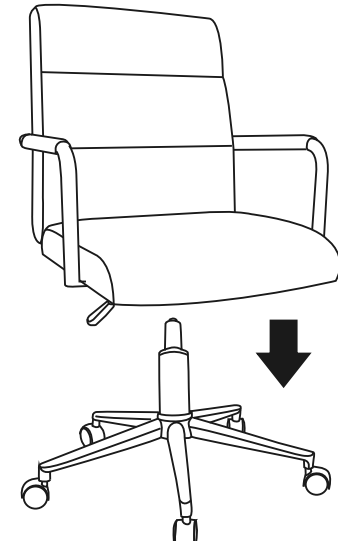
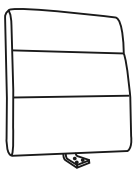

ASSEMBLY INSTRUCTION

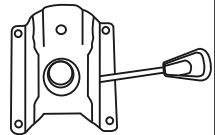
▽ PARTSxQTY

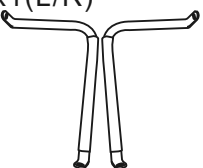
▽ ASSEMBLY PROGRAM

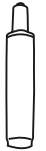
<p>①</p> 	<p>②</p> 	<p>③ please keep screws 80% tight first of all.</p> 
<p>④ please put the legs into flat platform, then after adjustment, keep screws 100% tight finally.</p> 	<p>⑤</p> 	

<p>AX1</p> 	<p>Gx5</p> 
<p>Bx1</p> 	<p>Hx7</p>  <p>M6x20mm</p>
<p>Cx1</p> 	<p>Ix4</p>  <p>M6x25mm</p>
<p>Dx1(L/R)</p> 	<p>Jx1</p> 
<p>Ex1</p> 	<p>Kx1</p> 
<p>Fx1</p> 