

# ASSEMBLY INSTRUCTIONS

---

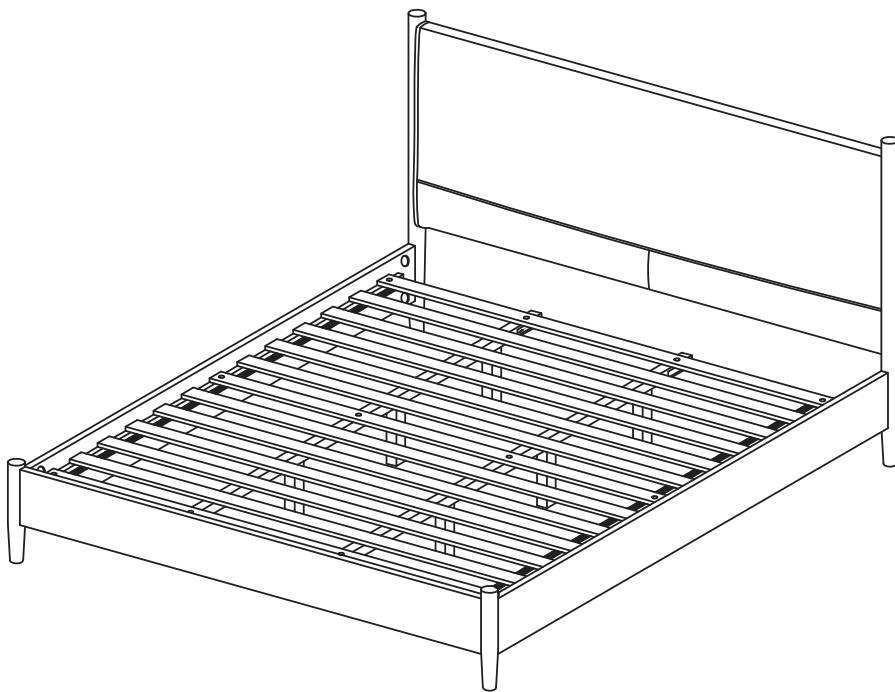

## TOOLS REQUIRED



Allen Wrench

(Included)



Phillips  
Screwdriver

(Not Included)



2 - Persons  
Recommended

## ASSEMBLY RATING



EASY ————— DIFFICULT

The Assembly Rating is a 5-point system showing the level of effort needed to assemble a specific product.

---

# PRE ASSEMBLY INTRODUCTION

We understand building ready-to-assemble furniture can be a challenging experience for some. To help avoid confusion, we have provided some helpful tips that may speed up the process.



## Teamwork

ALWAYS have at least two people to help with transporting and assembling the product to avoid potential injury and/or damage.

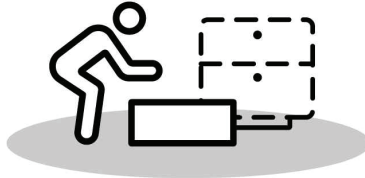
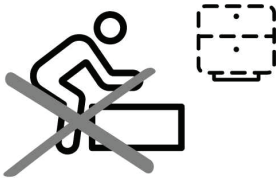

## Suitable Location

Assembling near the area of the intended location is highly recommended.



## Sufficient Space

Make sure you have enough space to move around during the assembly.

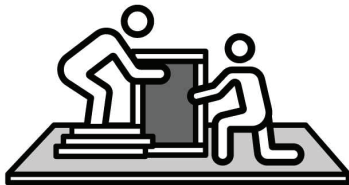

## Avoid Scratches

Use cardboard, blankets or a carpeted area while assembling furniture to prevent scratches.

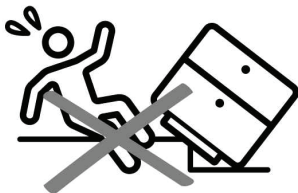

## Flat Surface

Make sure the furniture rests on a flat and level surface with each leg evenly touching the floor.

# ASSEMBLY AND CARE ADVICE



**FAILURE TO FOLLOW THE GUIDELINES BELOW MAY RESULT IN INJURY AND/OR PROPERTY DAMAGE.**



Position each part correctly and insert screws or bolts into their respective holes.



Turn clockwise to tighten and only tighten when step is completed or when instructed to do so.



Use the appropriate hand tools or power tools for assembly. Select steps, such as tightening screws and/or bolts, may require hand tools to avoid causing damage during assembly.



Save the instructions and store any supplied tools for later maintenance.



After two weeks, check and tighten any loose hardware and repeat again every six months thereafter.

**IT IS THE USER'S RESPONSIBILITY TO MAINTAIN THE FURNITURE. THE HARDWARE MAY LOOSEN OVER TIME AND MAY CAUSE THE FURNITURE TO BE WOBBLY AND UNABLE TO SUPPORT ITS INTENDED WEIGHT CAPACITY. THIS MAY LEAD TO COLLAPSE AND MAY CAUSE SERIOUS INJURY.**

# EASTERN KING BED



- Please keep instructions for future reference.
- Check the quantity and irregularity of parts and hardware before you start.

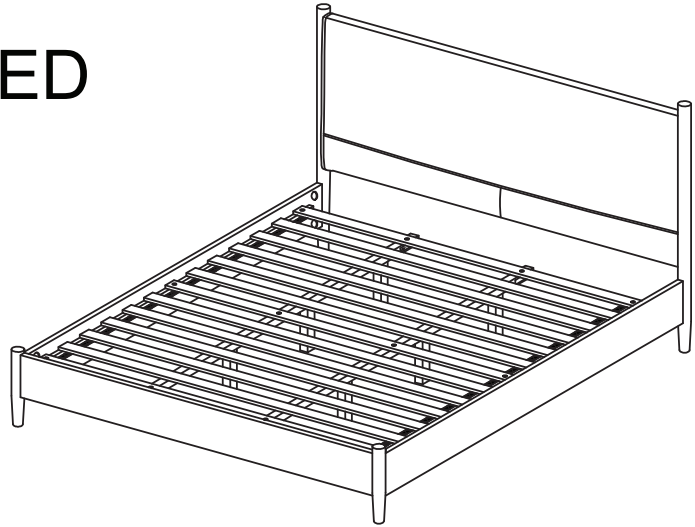

## PARTS

#1 1pc

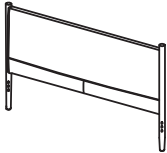

Headboard

#2 1pc



Footboard

#3 2pcs



Side Rail

#4 2pcs

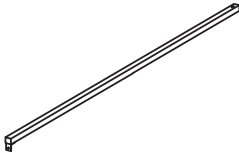

Center Rail

#5 6pcs



Support Leg

#6 1set

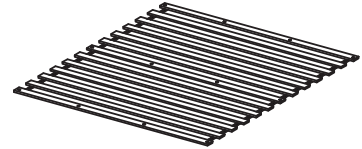

Slat

## HARDWARE

#A 10pcs



Jcbc Bolt M6 x 50mm

#B 8pcs



M6 Bend Washer 3013 (RB)

#C 10pcs



Wood Screw M4 x 38mm

#D 4pcs











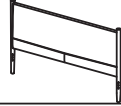

Wood Dowel M8 x 30mm

#E 1pc



M4 Allen Wrench

# POINT 3 CARTONS

Carton	Designation	Part		Hardware
	Headboard (1pc)	#1		
	Footboard (1pc)	#2		 #A x 10pcs  #B x 8pcs  #C x 10pcs  #D x 4pcs  #E x 1pc
	Side Rail (2pcs)	#3		
	Center Rail (2pcs)	#4		
	Support Leg (6pcs)	#5		
	Slat (1Set)	#6		

# ASSEMBLY INSTRUCTIONS

1

Part #3 x2pcs

Hardware #D x4pcs

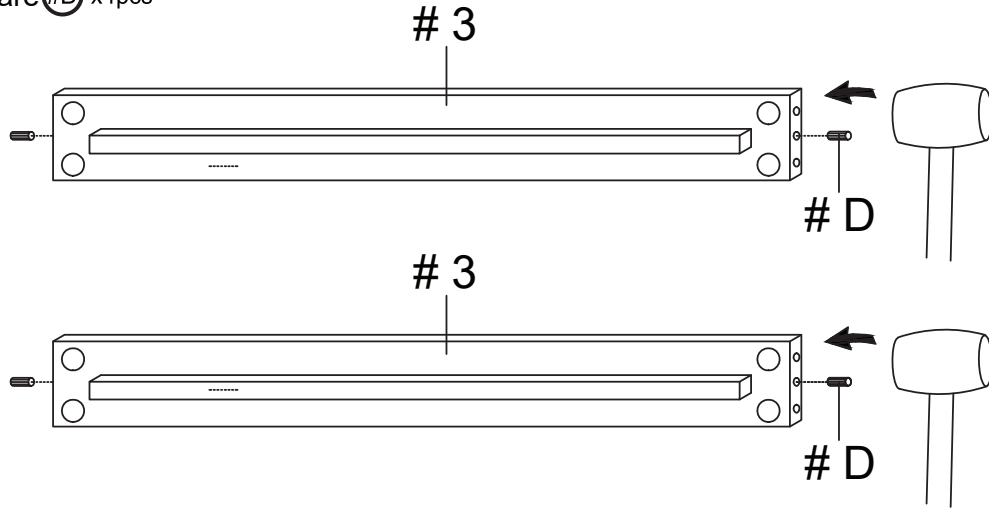

2

Part #2 x1pc

Part #3 x2pcs

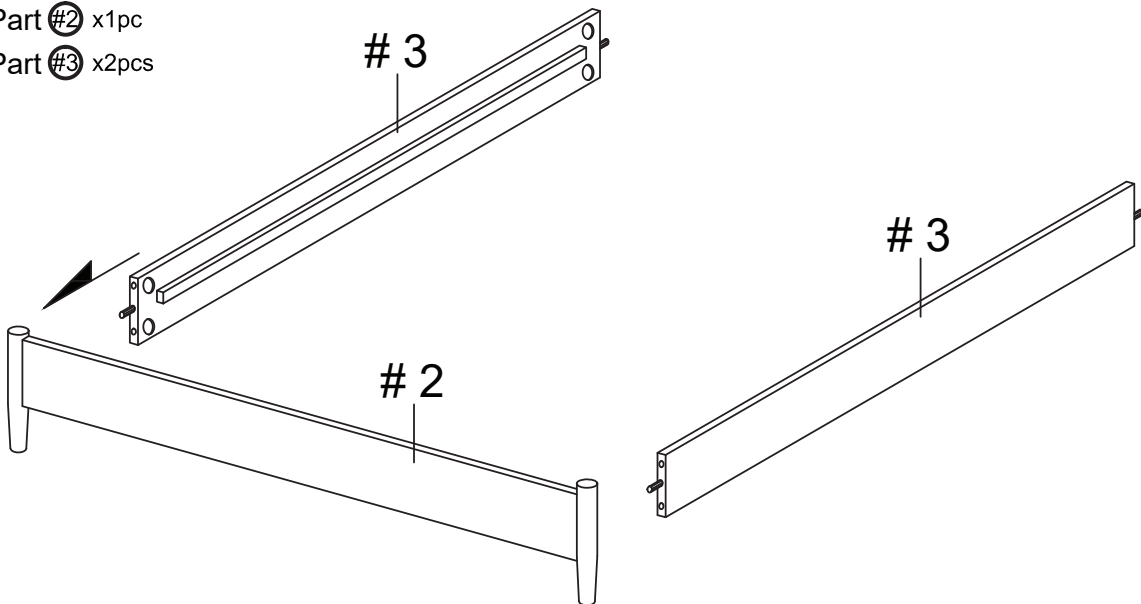

# ASSEMBLY INSTRUCTIONS

## 3

- Part #2 x1pc
- Part #3 x2pcs
- Hardware #A x4pcs
- Hardware #B x4pcs
- Hardware #E x1pc

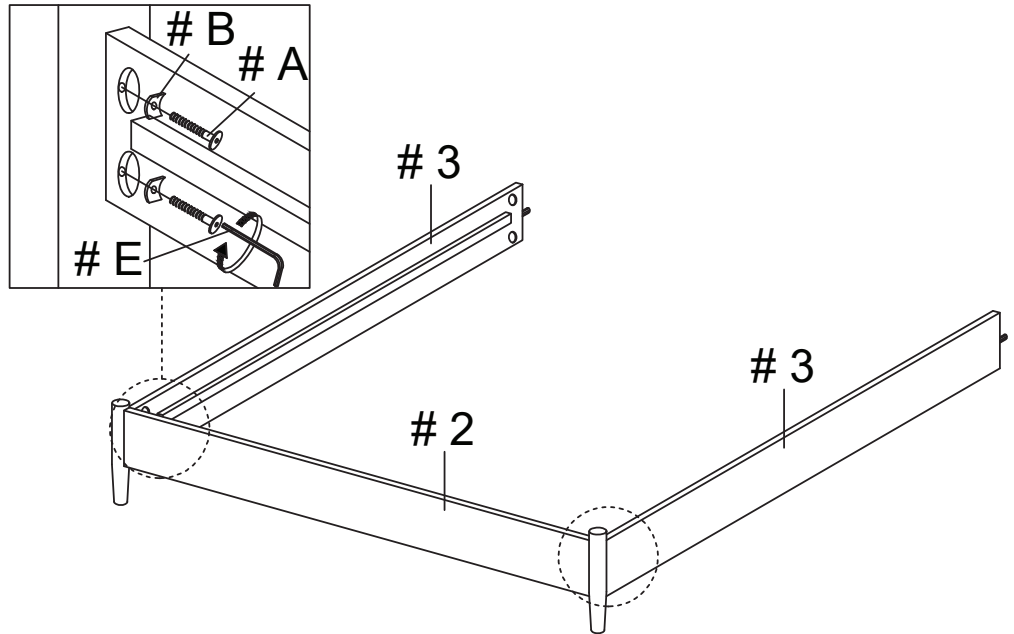

## 4

- Part #1 x1pc
- Part #3 x2pcs
- Hardware #A x4pcs
- Hardware #B x4pcs
- Hardware #E x1pc

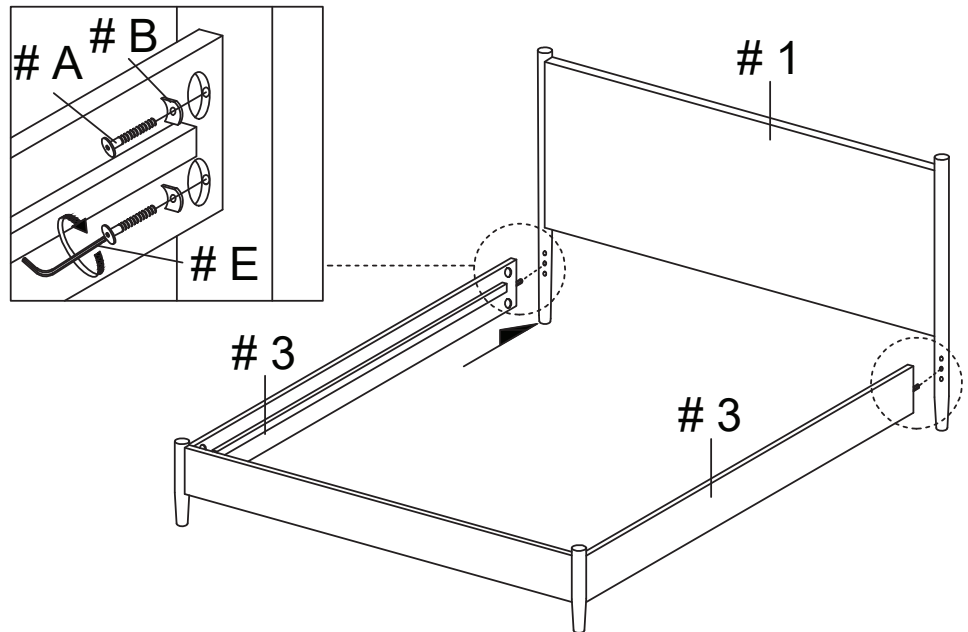

# ASSEMBLY INSTRUCTIONS

5

Part #4 x1pc  
Part #5 x3pcs

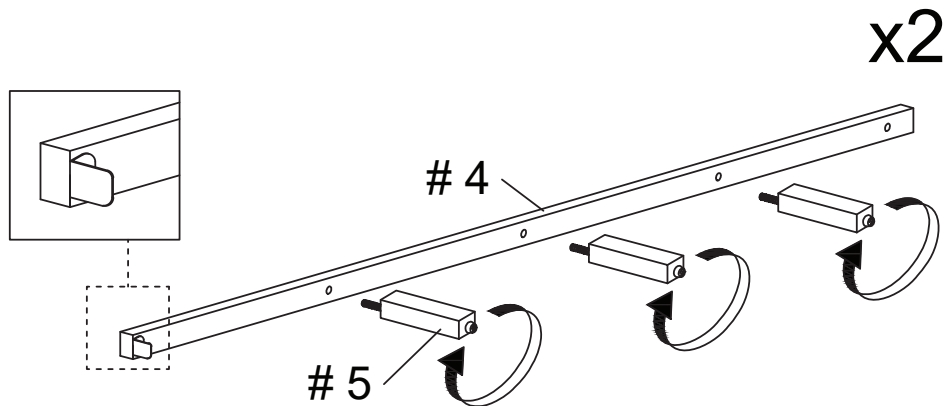

6

Part #2 x1pcs  
Part #4 x1pcs

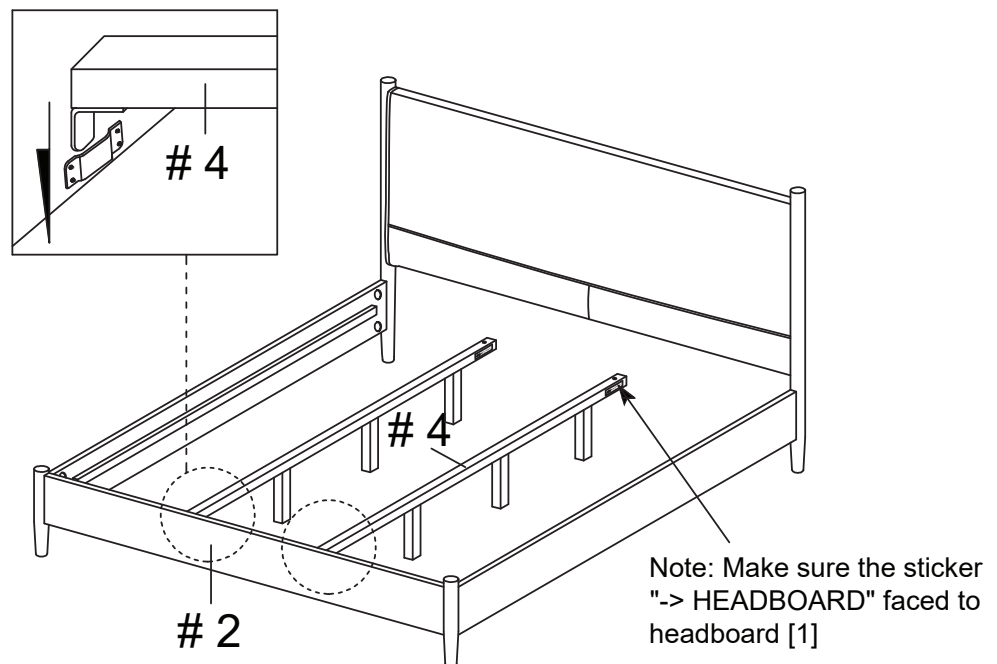

# ASSEMBLY INSTRUCTIONS

## 7

- Part #6 x1set
- Hardware #A x1pc
- Hardware #C x8pcs
- Hardware #E x1pc

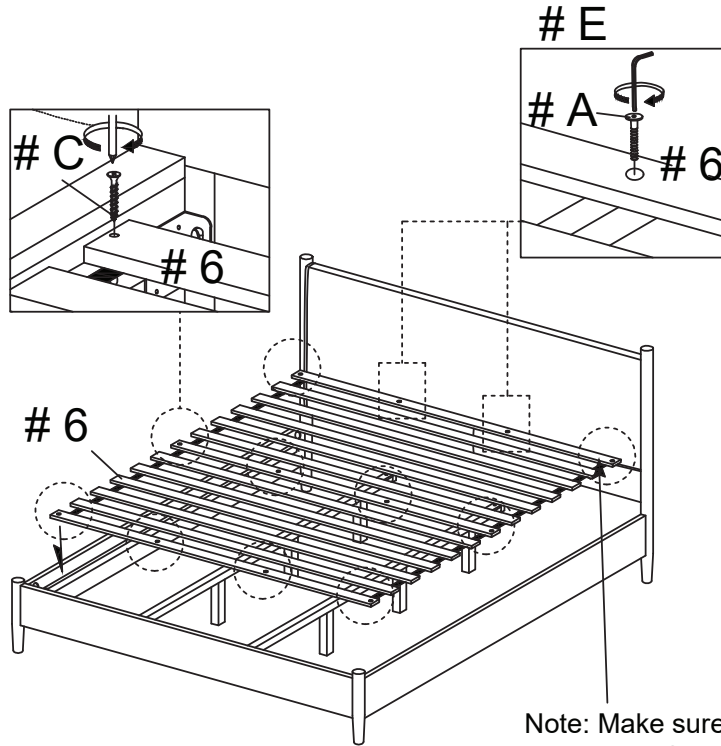

Note: Make sure the sticker  
"-> HEADBOARD" faced to  
headboard [1]

## 8

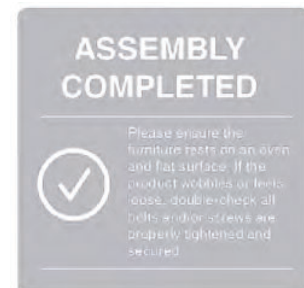
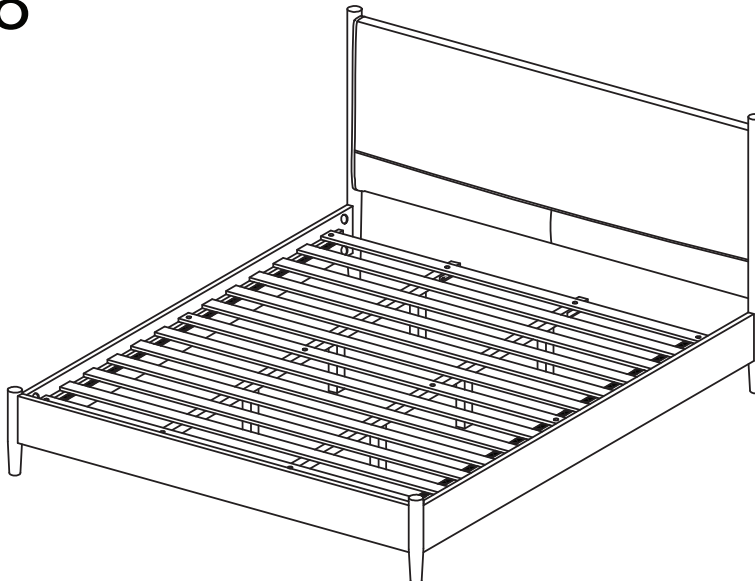

**Keep this handy!**  
Please retain this instruction manual and any order-related information for future reference.