



Vestil Manufacturing Company
 2999 North Wayne Street, P.O. Box 507, Angola, IN 46703
 Telephone: (260) 665-7586 -or- Toll Free (800) 348-0868
 Fax: (260) 665-1339
 Web: www.vestil.com e-mail: info@vestil.com

Balanced Load Lifter: OLF-4-42



Receiving Instructions

After delivery, remove the packaging from the product. Inspect the product closely to determine whether it sustained damage during transport. If damage is discovered, record a complete description of it on the bill of lading. If the product is undamaged, discard the packaging.

NOTE: The end-user is solely responsible for confirming that product design, use, and maintenance comply with laws, regulations, codes, and mandatory standards applied where the product is used.

Technical Service & Replacement Parts

For answers to questions not addressed in these instructions and to order replacement parts, labels, and accessories, call our Technical Service and Parts Department at (260) 665-7586. The department can also be contacted online at <https://www.vestil.com/page-parts-request.php>.

Electronic Copies of Instruction Manuals

Additional copies of this instruction manual may be downloaded from <https://www.vestil.com/page-manuals.php>.

Table of Contents		Page
Signal Words		2
Safety Instructions		2
OLF-4-42 Exploded View, Bill of Materials, & Specifications		3
National Standards		4
Using the Lifter		4 - 5
Record of Satisfactory Condition		5
Load Tests		5
Inspections and Maintenance		5 - 6
Labeling Diagram		6
Limited Warranty		7

SIGNAL WORDS

This manual uses SIGNAL WORDS to direct the reader's attention to important safety-related messages. These messages describe uses of the product that could result in personal injury or property damage. Each signal word corresponds to a specific hazard level.



Identifies a hazardous situation which, if not avoided, WILL result in DEATH or SERIOUS INJURY. Use of this signal word is limited to the most extreme situations.



Identifies a hazardous situation which, if not avoided, COULD result in DEATH or SERIOUS INJURY.



Identifies practices likely to result in product/property damage, such as operation that might damage the product.

SAFETY INSTRUCTIONS

Vestil strives to identify all foreseeable hazards associated with the use of its products. However, material handling is dangerous and no manual can address every conceivable risk. Ultimately, the most effective way to prevent injury is to apply sound judgment whenever using this device.

WARNING

Improper or careless use of this product could result in death or serious personal injuries.

- **Read and understand the entire manual before using, inspecting, or servicing the cylinder caddy.** DO NOT use this device until you read and understand the entire instruction manual. Read the manual to refresh your understanding of proper use and maintenance procedures.
- DO NOT exceed the rated load/capacity of your lifter. Capacity figures are provided on product labeling. See Label 320 in [LABELING DIAGRAM](#) on p. 6.
- Only use the lifter in accordance with the instructions in this manual, applicable provisions of ASME B30.20 Below-the-Hook (BTH) Lifting Devices, and all laws, regulations, codes, etc. that apply to BTH devices. Ensure all operators are trained & qualified as defined in ASME B30.20. Trainees must be supervised by qualified personnel.
- Confirm lifter compatibility with the hoist & crane (e.g. hook size, capacity, rigging) per ASME B30.20.
- DO NOT elevate the lifter if the hoist rope/chain is kinked. Make sure that multiple part lines are not twisted around each other before elevating the lifter.
- Center and evenly distribute the load on its pallet before engaging the pallet with the lifter. The load must not overhang any side of its pallet.
- Adjust the position of the lifting bale to balance the lifter before elevating it. The forks of the lifter must be horizontal when the lifter and load are elevated. If a load cannot be balanced, do not use the lifter to elevate it. Select another lifting device.
- DO NOT modify the product in any way UNLESS you first obtain written approval from Vestil. Unapproved modifications automatically void the [LIMITED WARRANTY](#) (p. 7) and might make the product unsafe to use.
- Avoid load (and lifter) swinging by making sure the hoist rope/chain is vertical before elevating the load.
- Slowly and carefully raise, lower, and move the lifter when it is loaded and when it is not loaded. DO NOT start or stop suddenly. Sudden change could cause the load to slide on the forks.
- DO NOT contact any obstructions with either the load or the lifter. Make sure the path of travel is clear before elevating and moving the lifter.
- NEVER lift people or carry loads over people.
- DO NOT use the lifter for side pulls or for sliding loads.
- DO NOT climb on the lifter or ride on it or the load, or allow others to climb or ride on the lifter or load.
- DO NOT leave the lifter unattended while it is elevated. Land the load and store the lifter before leaving it.
- Guide the lifter by grasping both operator handles. Keep clear of the lifter while moving it. In particular, keep feet out from underneath the lifter at all times. Make sure that clothing cannot become entangled in the load or with the lifter.
- DO NOT remove or deface labels applied to the unit. DO NOT use this device UNLESS each label is in place, undamaged, and easily readable from a reasonable distance. See [LABELING DIAGRAM](#) on p. 6.
- Inspect the product as instructed in [INSPECTIONS AND MAINTENANCE](#) on p. 5-6.
- DO NOT use this lifter if it is damaged, malfunctioning, or missing parts.
- DO NOT elevate the lifter more than necessary to move it. Keep it as close to the ground as possible.
- DO NOT use the lifter if it is tagged "Out of service" or is otherwise designated as malfunctioning.

OLF-4-42 EXPLODED VIEW AND BILL OF MATERIALS 38-006-006

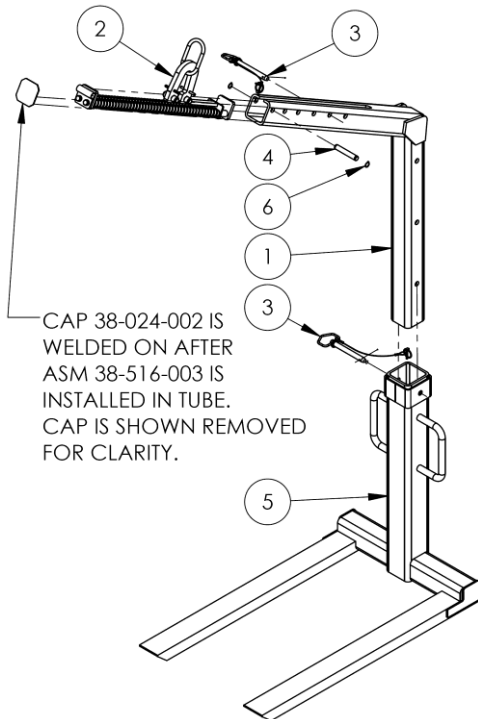

ITEM	PART NO.	DESCRIPTION	QTY.
1	38-514-003	WELDMENT, FRAME HOIST TUBE	1
2	38-516-003	BRACKET, SPRING BALANCE SUB- ASSEMBLY	1
3	99-112-057	PIN HEIGHT ADJUSTMENT	2
4	38-112-002	PIN, HOIST	1
5	38-514-006	WELDMENT, FRAME, BASE SUB-ASSEMBLY	1
6	38-117-001	RETAINER RING, EXTERNAL FOR Ø3/4 SHAFT	2

SPECIFICATIONS

Documents that provide specifications for OLF-series lifters are available online to anyone who visits Vestil's website. Specifications include dimensions, net weight, and capacity information. To access the appropriate specifications document, navigate to this webpage: <https://www.vestil.com/product.php?FID=575>. Click the "Specifications" tab. Scroll the page to the entry for the model ladder you purchased, and click the button in the "PDF" column that looks like a pencil inside a blue-bordered box. A PDF file will open. This file is the specifications document. Print a copy of the document and keep it with your copy of this manual. The following specifications document is up-to-date as of the date this manual was written (see header).

FIXED OVERHEAD LOAD LIFTER - OLF-4-42

APPROX WEIGHT: 453.39 lbs.
DOES NOT INCLUDE WEIGHT OF POWER OR PACKAGING!!!

*** ANY ADDITIONS, DELETIONS, OR OMISSIONS MUST BE CORRECTED ON THIS DRAWING AS THIS DRAWING WILL BE CONSIDERED ALL INCLUSIVE ***
ALL GRAPHICS PROVIDED ARE FOR REFERENCE ONLY. IF CERTAIN DIMENSIONS ARE CRITICAL PLEASE VERIFY THOSE DIMENSIONS WITH YOUR SALESPERSON

STANDARD FEATURES

MODEL NUMBER IS OLF-4-42
MAX CAPACITY IS 4,000 LBS
ADJUSTABLE CLEARANCE HEIGHT IS 38 3/4", 50 1/2", AND 62 1/4"
OVERALL HEIGHT ADJUSTS TO 62 9/16", 74 5/16", AND 86 1/16"
FORKS ARE FIXED/ NON ADJUSTABLE
FORK SIZE IS 2" H X 4" W
USABLE FORK LENGTH IS 43 1/8"
OVERALL WIDTH IS 27 1/2"
OVERALL LENGTH IS 48 1/8"
DURABLE LIQUID PAINT BLUE FINISH

SPECIAL FEATURES

NONE

BAIL SLIDES UP AND IS STOPPED BY ADJUSTMENT PIN WHEN LIFTING A LOAD

SHOWN AT MAX HEIGHT

ADJUSTABLE BAIL FULLY RETRACTED BY SPRING

120°

ADJUSTABLE CLEARANCE HEIGHT

43 1/8"

48 1/8"

27 1/2"

4"

19"

BAIL POSITION ADJUSTMENT PIN

HEIGHT ADJUSTMENT PIN

OVERALL HEIGHT

2"

DIMENSION TOLERANCE +/- 1/4"

I, THE UNDERSIGNED, AGREE THAT THE PRODUCT AS REPRESENTED SATISFIES DESIGN AND DIMENSION REQUIREMENTS. I ALSO ACKNOWLEDGE MY DUTY TO CONFIRM PRODUCT AND INSTALLATION COMPLIANCE WITH ALL APPLICABLE FEDERAL, STATE AND LOCAL REGULATIONS AND STANDARDS.

ANY MODIFIED UNITS ARE NON-RETURNABLE

[] As drawn [] As marked

Signed: _____ Date: _____

Printed Name: _____

LEAD TIME WILL START UPON RECEIPT OF SIGNED APPROVAL DRAWING

FOR INTERNAL USE ONLY PROJECT SIGN OFF	DISTRIBUTOR'S NAME:
SALES	VESTIL MANUFACTURING
ENG.	DRAWN BY: _____ DATE: _____
FAB.	REFERENCE: X SCALE: 1:22
POWER	QUOTED LEAD TIME: X QUOTE # X
	F.O.# X W.O.# X SALES: X FILE NAME: 38-007-006

NATIONAL STANDARDS

OLF-series products are Below-the-Hook lifting (BTH) devices designed to facilitate handling of palletized loads. American National Standard ASME B30.20 (the “Standard”), which can be purchased online at <https://www.asme.org/codes-standards/find-codes-standards/b30-20-hook-lifting-devices> provides inspection, testing, maintenance, and operation instructions for users of BTH devices. Acquire a copy of the Standard. Apply all mandatory provisions of Chapter 20-1: *Structural and Mechanical Lifting Devices*. Contact local occupational safety and health specialists to determine whether there are laws, ordinances, codes, etc. (“authorities”) in addition to the Standard that apply to BTH pallet handlers in the location where the handler will be used. If content in this manual conflicts with provisions in authorities or the Standard, apply the provisions from the authorities or Standard. Contact **TECHNICAL SERVICE** to report conflicts.

USING THE LIFTER

This lifter is a below-the-hook lifting device, design category B (used for loads and variations which are severe and not accurately defined), service class 1 (20,001 to 100,000 load cycles). It should only be operated by qualified personnel. ASME B30.20 defines *qualified person* as “a person who, by the possession of a recognized degree in an applicable field or certificate of professional standing, or who, by extensive knowledge, training, and experience, has successfully demonstrated the ability to solve or resolve problems relating to the subject matter at hand.” Qualified persons include designated persons, trainees under the direct supervision of a designated person, maintenance personnel, test personnel, and inspectors.

ADJUSTING THE LIFTER

Height of OLF-series lifters is adjustable. Adjust the height by removing the height adjustment pin (99-112-057). Pull the inner frame tube up. Align the pin holes in the inner and outer frame tubes; then reinstall the height adjustment pin.

LOADING THE LIFTER

Make sure that loads are centered and evenly distributed on their pallets. Make sure that loads are securely bound to their pallets before lifting them. If loose items fall off of the pallet while the lift is underway, people could be injured. The center of gravity of the load also changes if load items fall off of a pallet. Shifting center of gravity could cause the lifter to tip and the rest of the load could be lost.

1. Attach the hoist hook to the connection link.
2. Stand behind the lifter. Grasp both operator handles. Fully insert the forks into the fork channels of the pallet.
3. Slowly raise the lifter. Check load balance and stability. The forks should be level front-to-back and side-to-side. If the lifter tilts forward or backward, the position of the lifting bale must be adjusted. Lower the lifter to the ground. Then,
 - a. Remove the bale adjustment pin.
 - b. Slide the bale along the lifting arm. Reinstall the pin.
 - i. Lifter tilts forward (fork tips down): Shift the bale towards the free end of the lifting arm.
 - ii. Lifter tilts backward: Shift the bale towards the back of the lifting arm. Minimize swinging! Make sure that the hoist is centered above the bale, i.e. hoist chain/rope is vertical. If the hoist chain/rope is not vertical, the lifter will swing as it is elevated.

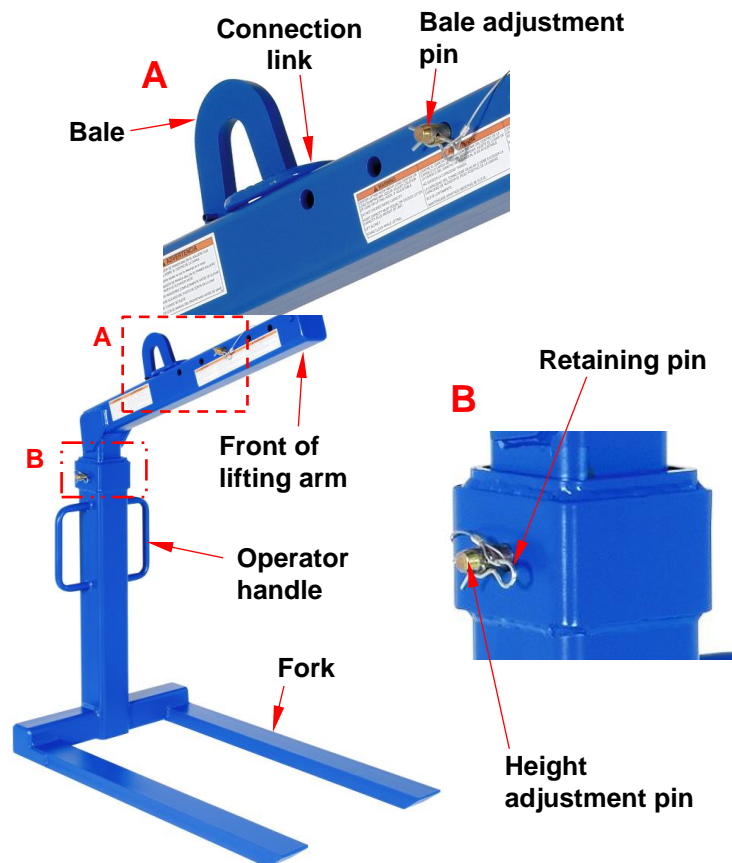

CONTINUED ON P. 5

LOADING THE LIFTER (CONTINUED FROM P. 4)

4. Slowly raise the lifter. Watch the device as it elevates. If the lifter begins to tilt forwards or backwards, return the lifter to the ground and adjust bale position as described in step 3. Raise the lifter again to determine whether it is balanced. If balance has been achieved, proceed to the next step. Otherwise, try again to balance the lifter. If the lifter cannot be balanced, use another lifting device to handle the load.
5. Stand behind the lifter. Grasp both operator handles and gradually begin pushing the lifter in the necessary direction. Avoid sudden starts and stops.
6. Lower the lifter onto even, level ground. Make sure that the pallet and load are stable and entirely supported by the ground.
7. Raise the lifter just enough to carefully withdraw the forks from the pallet. Before leaving the lifter, lower it to the ground and disconnect the hoist chain/rope from the bale.

RECORD OF SATISFACTORY CONDITION (THE “RECORD”)

Record the condition of the lifter before putting it into regular service. Thoroughly photograph the unit from multiple angles. Include close range photos of all labeling, the forks, bale, connecting link, and bale pin, height adjustment pin, and all welds. Measure the length and width of the bale opening and connecting link. Record your measurements. Write a description of the overall condition of the lifter. Collate the photographs and writings into a single file. Mark the file appropriately to identify it. The file is a record of the lifter in satisfactory condition. Compare the results of all inspections to this *RECORD* to determine whether the unit is in satisfactory condition. If the lifter is not in satisfactory condition, repair it before returning it to service. Purely cosmetic changes, like damaged paint/powdercoat, do not constitute changes from satisfactory condition. However, touchup paint should be applied to all affected areas as soon as cosmetic damage occurs to prevent rusting and corrosion. If left unaddressed, rust/corrosion will degrade the condition of the lifter and could make it unsafe to use.

LOAD TESTS

After creating a *RECORD OF SATISFACTORY CONDITION* and before using the lifter for the first time, a qualified person should conduct a load test. The test load should be 125% of the rated load, i.e. $4000\text{lb.} \times 1.25 = 5000\text{lb.}$ (2272.7kg). Elevate the lifter a few inches above the ground. After a couple minutes, return it to the ground and unload it. Perform a *Monthly Inspection* as described in *INSPECTIONS AND MAINTENANCE* on p. 5-6. The (qualified) person performing the test must compose a written report confirming the load rating of the lifter. The load rating should not be more than 80% of the test load. The lifter must undergo load testing whenever it is repaired. Never modify the lifter without first obtaining written approval from Vestil.

INSPECTIONS & MAINTENANCE

NOTICE

Regular inspections and maintenance are essential. Always inspect and maintain this product in accordance with the instructions in this manual.

Inspections and repairs should be performed by qualified persons. Compare the results of each inspection to the *RECORD OF SATISFACTORY CONDITION*. Do not use the lifter unless all parts are in satisfactory condition. Replace parts that are not in satisfactory condition before returning the lifter to service. Only use manufacturer-approved replacement parts to restore the unit to satisfactory condition. **DON'T GUESS! If you have any questions about the condition of your lifter, contact the *TECHNICAL SERVICE* department.** The phone number is provided on the cover page of this manual. Never make temporary repairs of damaged or missing parts.

Every lift – The operator must inspect the lifter before every lift. Closely inspect the bale mechanisms. Check the connecting link, bale loop, and bale pin for cracks, elongation, warps, and other forms of damage. Confirm that the bale mechanism is securely pinned in place. Remove debris from the surfaces of the forks.

Monthly Inspections – At least once per month a qualified person must perform the following inspections. Written reports should be prepared for every monthly inspection including inspections following *LOAD TESTS*.

1. **Frame elements:** Examine all frame elements (inner frame tube; outer frame tube; lifting arm) for deformation, cracks, severe wear, corrosion/rusting, and metal fatigue. If rusting is purely superficial,

- remove it with a steel bristle brush or steel wool. Clean the affected area and apply touchup paint. If rusting, rot, or thinning has weakened the material, contact **TECHNICAL SERVICE** for advice.
- Pins and fasteners:** Examine all pins (bale pin; height adjustment pin). Pins should be straight. Examine retaining clips used to secure pins in place.
 - Bale assembly:** Measure the length and width of the bale opening and connecting link. Make sure the measurements match the measurements in the **RECORD**.
 - Forks:** Thoroughly examine both forks. Look for cracks and severe wear. Confirm that each fork is solidly welded to the frame.
 - Labels:** Check all labels. Labels are shown in the **LABELING DIAGRAM** (below). Replace labels that are missing, damaged, or not easily readable.

LABELING DIAGRAM

Label content and location are subject to change so your product might not be labeled exactly as shown. Compare the diagram below with the **RECORD**. If you have any questions about labeling, contact **TECHNICAL SERVICE**. Replace all labels that are damaged, missing, or not easily readable (e.g. faded). To order replacement labels, contact the technical service and parts department online at <https://www.vestil.com/page-parts-request.php>. Alternatively, request replacement parts and/or service by calling (260) 665-7586 and asking the operator to connect you to **TECHNICAL SERVICE**.

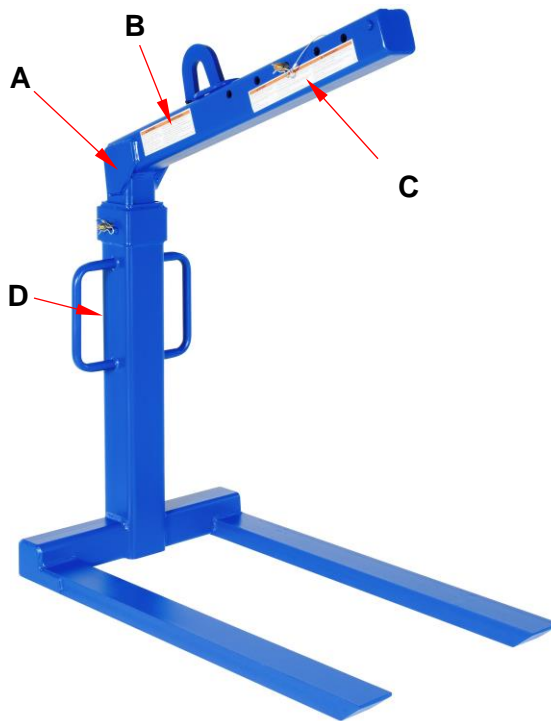

A: Label 991



B: Label 675

▲ WARNING	▲ ADVERTENCIA
<ul style="list-style-type: none"> • DO NOT exceed rated capacity • DO NOT use if damaged, malfunctioning, or missing parts • DO NOT lift people OR lift loads over people • DO NOT raise load higher than necessary • DO NOT leave a suspended load unattended • DO NOT use lifter unless you read and understand the owner's manual • DO NOT alter OR modify lifter • DO NOT remove OR obscure any label • STAY CLEAR of suspended loads • Secure load before using this device 	<ul style="list-style-type: none"> • NO exceda la capacidad tasada • NO USE is las partes estan dañadas, no funcionan correctamente o faltan partes. • NO eleve al personal o eleve cargas sobre el personal • NO eleve la carga mas alto de lo necesario • NO deje desatendida una carga que este suspendida • NO use el elevador a no ser que haya leído y entendido las instrucciones del manual del propietario • NO altere o modifique el elevador • NO quite u oscurezca ninguna etiqueta • MANTENGASE alejado de las cargas suspendidas • Asegure la carga antes de usar este dispositivo

C: Label 531

▲ WARNING	▲ ADVERTENCIA
PLACE BAIL STOP PIN IN HOLE THAT WILL STOP BAIL OVER CENTER OF LOAD. Failure to do this may result in load dumping. PLACE BAIL STOP PIN IN FIRST HOLE WHEN MOVING EMPTY LIFTER. FULLY INSERT PINS BEFORE LIFTING. KEEP CLEAR OF PINCH POINT ON TOP. STAND CLEAR WHILE LIFTING. CONSULT OWNERS MANUAL BEFORE USE.	PONGA EL PASADOR DE PARADA BAIL EN EL AGUJERO QUE PARA EL BAIL SOBRE EL CENTRO DE LA CARGA. Si no se hace podria resultar en que la descarga de la carga. PONGA EL PASADOR DE PARADA BAIL EN EL PRIMER AGUJERO CUANDO SE MUEVA EL ELEVADOR VACIO. INSERTE LOS PASADORES COMPLETAMENTE ANTES DE ELEVAR. MANTENGASE ALEJADO DEL PUNTO DE CORTE EN LA CIMA. APARTESE CUANDO SE ELEVE. CONSULTE CON EL MANUAL DEL PROPIETARIO ANTES DE USAR.

D: Label 320

MODEL NUMBER/NUMERO MODELO _____	
RATED LOAD _____	LBS.
CARGA TASADA _____	KGS.
WEIGHT OF LIFTER _____	LBS.
PESO DE LA UNIDAD _____	KGS.
SERIAL NUMBER/NUMERO DE SERIE: _____	
BTH-1 Design Category/Diseño BTH-1 Categoría: _____	B
BTH-1 Service Category/Servicio BTH-1 Categoría: _____	F
VESTIL MANUFACTURING COMPANY	
Angola, Indiana USA • Phone (260) 665-7586	
sales@vestil.com • www.vestil.com	
	320 rev 04/20



LIMITED WARRANTY

Vestil Manufacturing Company (“Vestil”) warrants this product to be free of defects in material and workmanship during the warranty period. Our warranty obligation is to provide a replacement for a defective, original part covered by the warranty after we receive a proper request from the Warrantee (you) for warranty service.

Who may request service?

Only a warrantee may request service. You are a warrantee if you purchased the product from Vestil or from an authorized distributor AND Vestil has been fully paid.

Definition of “original part”?

An original part is a part used to make the product as shipped to the Warrantee.

What is a “proper request”?

A request for warranty service is proper if Vestil receives: 1) a photocopy of the Customer Invoice that displays the shipping date; AND 2) a written request for warranty service including your name and phone number. Send requests by one of the following methods:

<u>US Mail</u>	<u>Fax</u>	<u>Email</u>
Vestil Manufacturing Company 2999 North Wayne Street, PO Box 507 Angola, IN 46703	(260) 665-1339 <u>Phone</u> (260) 665-7586	info@vestil.com Enter “Warranty service request” in subject field.

In the written request, list the parts believed to be defective and include the address where replacements should be delivered. After Vestil receives your request for warranty service, an authorized representative will contact you to determine whether your claim is covered by the warranty. Before providing warranty service, Vestil will require you to send the entire product, or just the defective part (or parts), to its facility in Angola, IN.

What is covered under the warranty?

The warranty covers defects in the following original, dynamic parts: motors, hydraulic pumps, motor controllers, and cylinders. It also covers defects in original parts that wear under normal usage conditions (“wearing parts”), such as bearings, hoses, wheels, seals, brushes, and batteries.

How long is the warranty period?

The warranty period for original dynamic components is 90 days. For wearing parts, the warranty period is 90 days. Both warranty periods begin on the date Vestil ships the product to the Warrantee. If the product was purchased from an authorized distributor, the periods begin when the distributor ships the product. Vestil may, at its sole discretion, extend a warranty period for products shipped from authorized distributors by up to 30 days to account for shipping time.

If a defective part is covered by the warranty, what will Vestil do to correct the problem?

Vestil will provide an appropriate replacement for any *covered* part. An authorized representative of Vestil will contact you to discuss your claim.

What is not covered by the warranty?

The Warrantee (you) are responsible for paying labor costs and freight costs to return the product to Vestil for warranty service.

Events that automatically void this Limited Warranty.

- Misuse;
- Negligent assembly, installation, operation or repair;
- Installation/use in corrosive environments;
- Inadequate or improper maintenance;
- Damage sustained during shipping;
- Collisions or other accidents that damage the product;
- Unauthorized modifications: Do not modify the product IN ANY WAY without first receiving written authorization from Vestil.

Do any other warranties apply to the product?

Vestil Manufacturing Co. makes no other express warranties. All implied warranties are disclaimed to the extent allowed by law. Any implied warranty not disclaimed is limited in scope to the terms of this Limited Warranty. Vestil makes no warranty or representation that this product complies with any state or local design, performance, or safety code or standard. Noncompliance with any such code or standard is not a defect in material or workmanship.