

Bed Frame

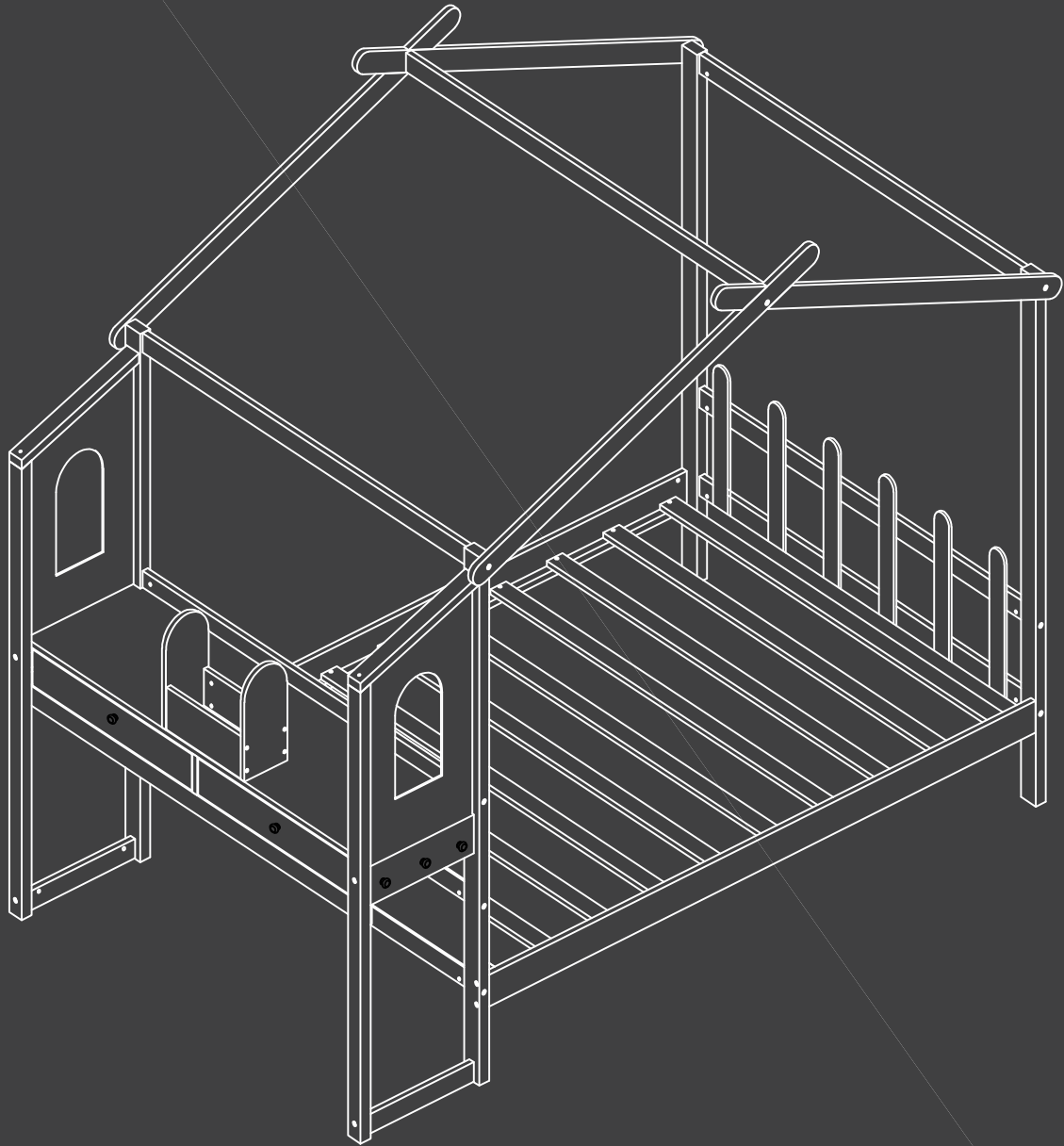

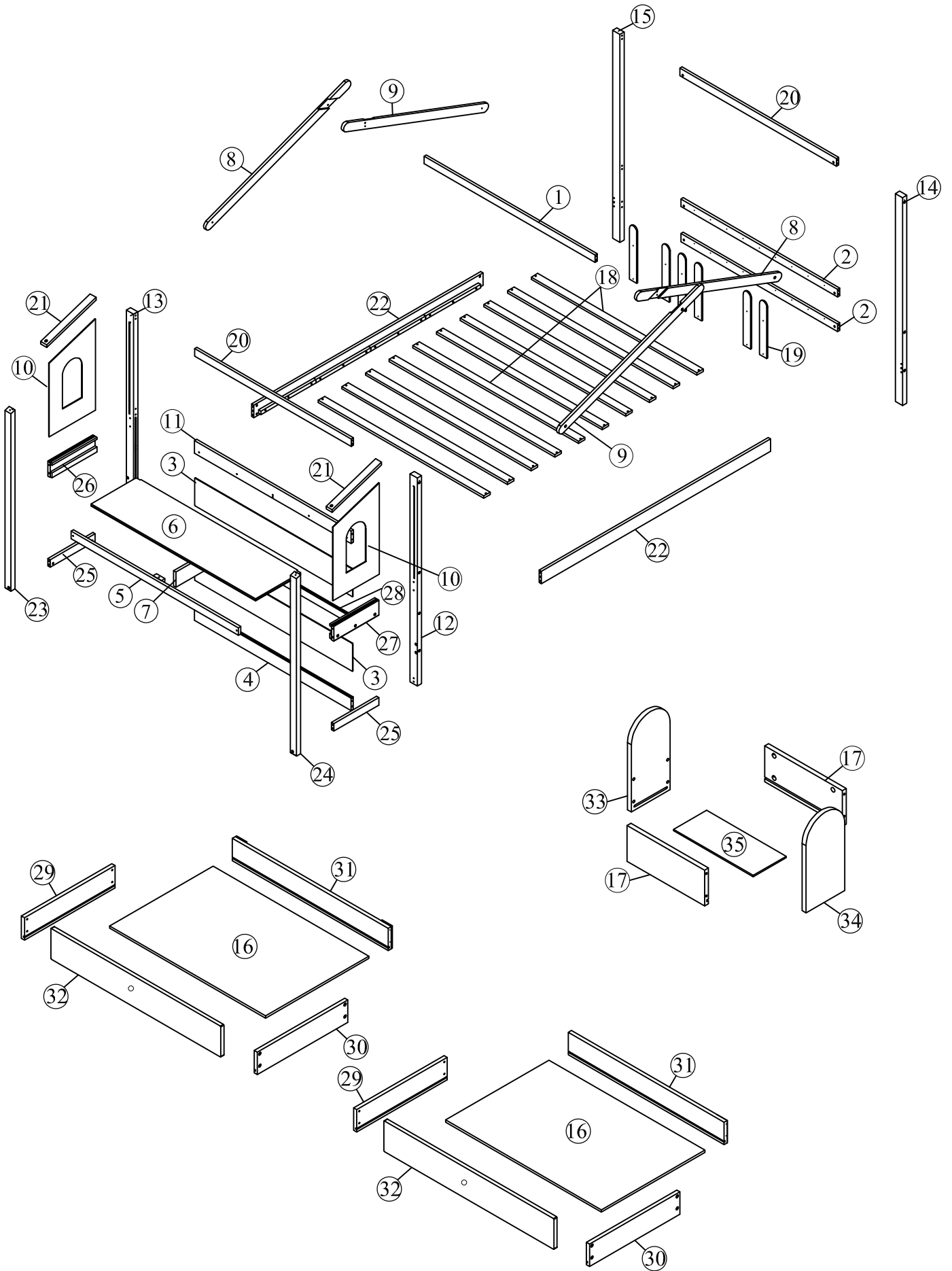



Instruction Manual

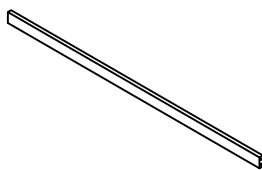
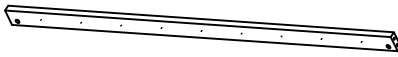
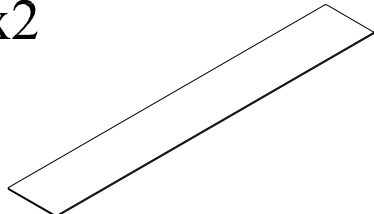
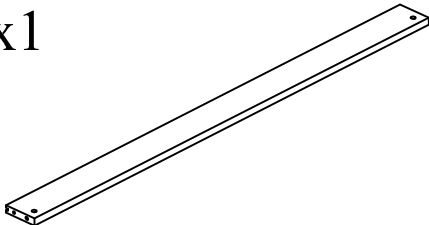
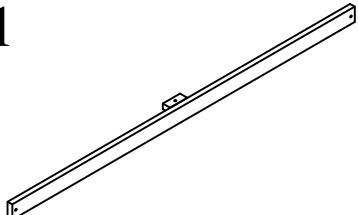
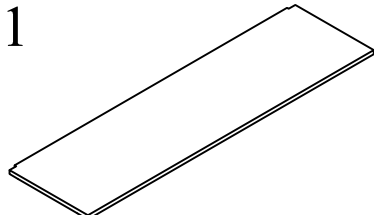
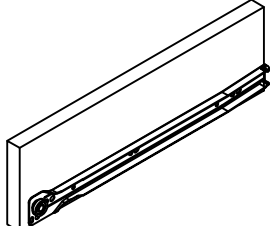

Detail:

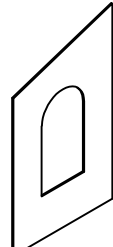

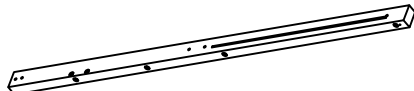
Part List (BOX 1)

① x1 	② x2 
③ x2 	④ x1 
⑤ x1 	⑥ x1 
⑦ x1 	⑧ x2 
⑨ x2 	⑩ x2 
⑪ x1 	⑫ x1 
⑬ x1 	⑭ x1 

Part List (BOX 1)





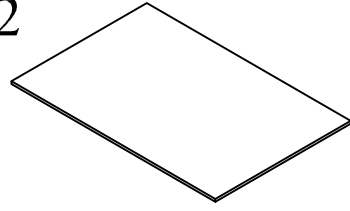

15 x1

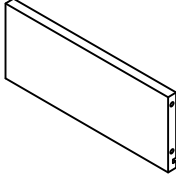
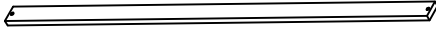

16 x2

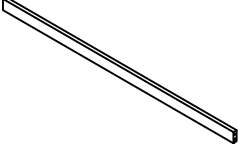
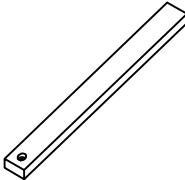

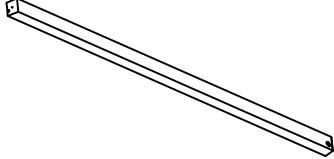
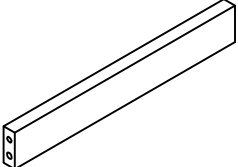
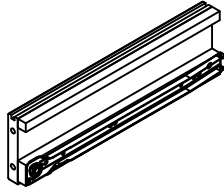
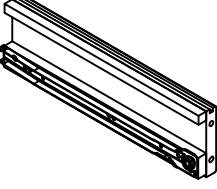

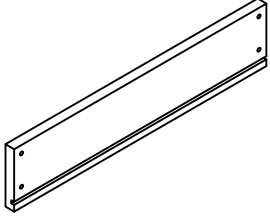
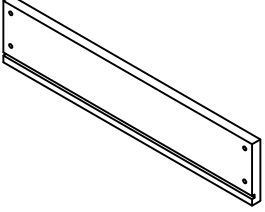



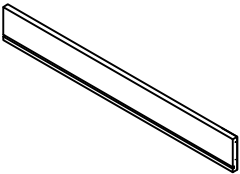
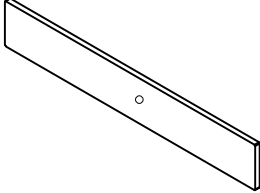
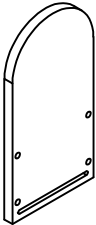
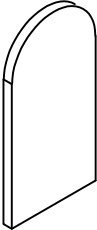
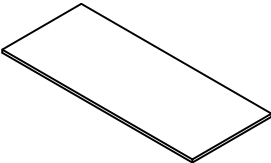



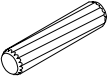
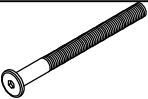



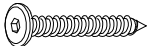

Part List (BOX 2)

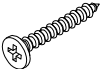
<p>①7 x2</p> 	<p>①8 x10</p> 
<p>①9 x6</p> 	<p>②0 x2</p> 
<p>②1 x2</p> 	<p>②2 x2</p> 
<p>②3 x1</p> 	<p>②4 x1</p> 
<p>②5 x2</p> 	<p>②6 x1</p> 
<p>②7 x1</p> 	<p>②8 x1</p> 
<p>②9 x2</p> 	<p>③0 x2</p> 

Part List (BOX 2)

<p>③1 x2</p> 	<p>③2 x2</p> 
<p>③3 x1</p> 	<p>③4 x1</p> 
<p>③5 x1</p> 	

Hardware List (BOX1)

No.	OUTLOOK	DESC	QTY
(A)		Dowel Ø8*30mm	32pcs
(B)		Bolts M6*100mm	14pcs
(C)		Bolts M6*80mm	16pcs
(D)		Bolts M6*60mm	4pcs
(E)		Bolts M6*30mm	1pc
(F)		Bolts M6*45mm	4pcs
(G)		Bolts M6*30mm	7pcs
(H)		Pat L	2pcs
(I)		Cross dowel M6*13mm	34pcs
(J)		Cross dowel Ø10*10mm	16pcs
(K)		Flat head screw #8*60mm	16pcs
(L)		Flat head screw #8*30mm	20pcs
(M)		Flat head screw #8*25mm	8pcs
(N)		Flat head screw #7*12mm	4pcs
(O)		Round head screw #8*20mm	12pcs
(P)		Allen key 60*22*4mm	1pc
(Q)		Handle	2pcs
(X)		Handle	6pcs

ASSEMBLY TOOLS REQUIRED (NOT INCLUDED)

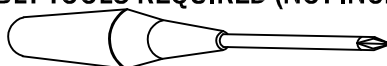



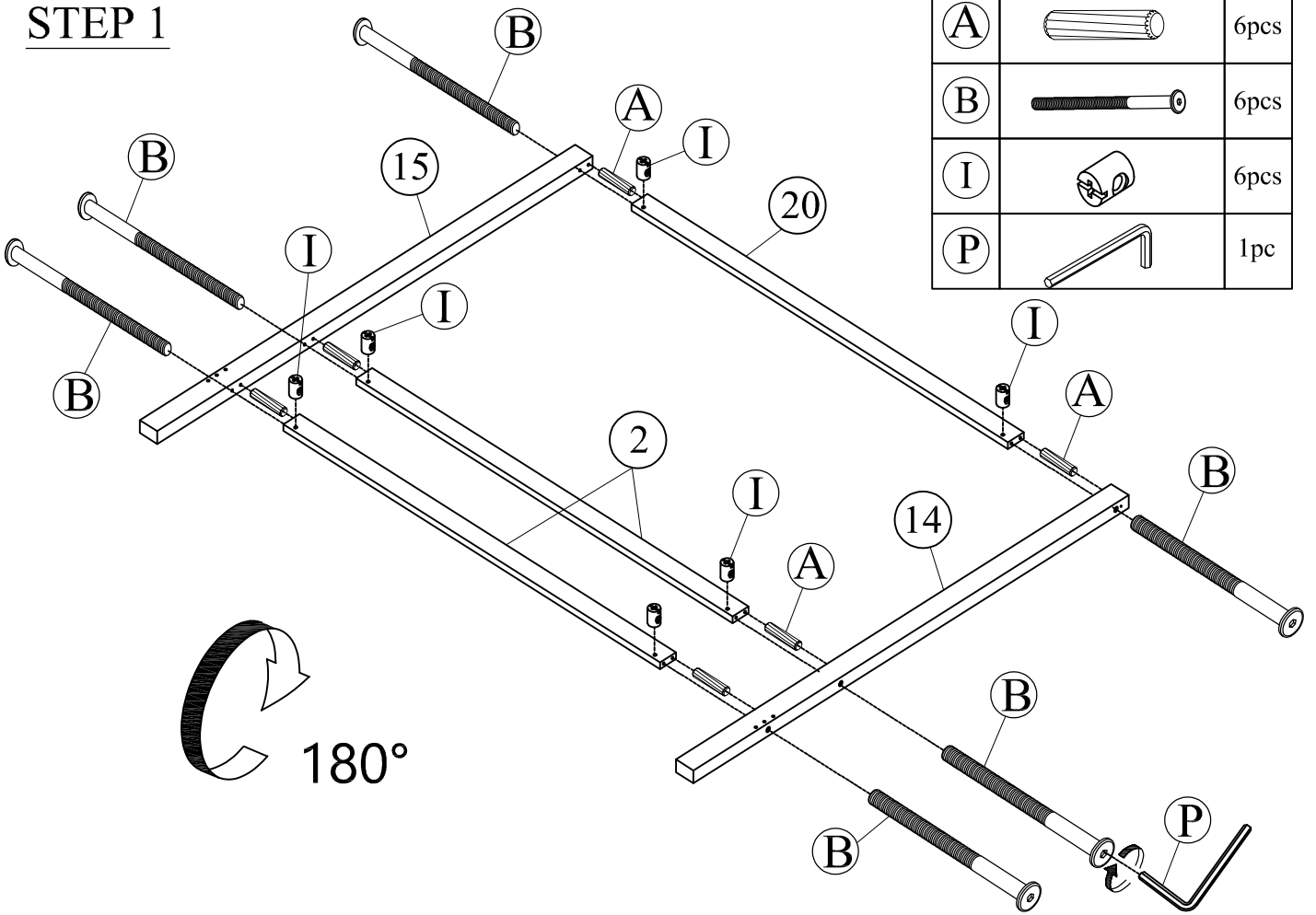

STEP 1

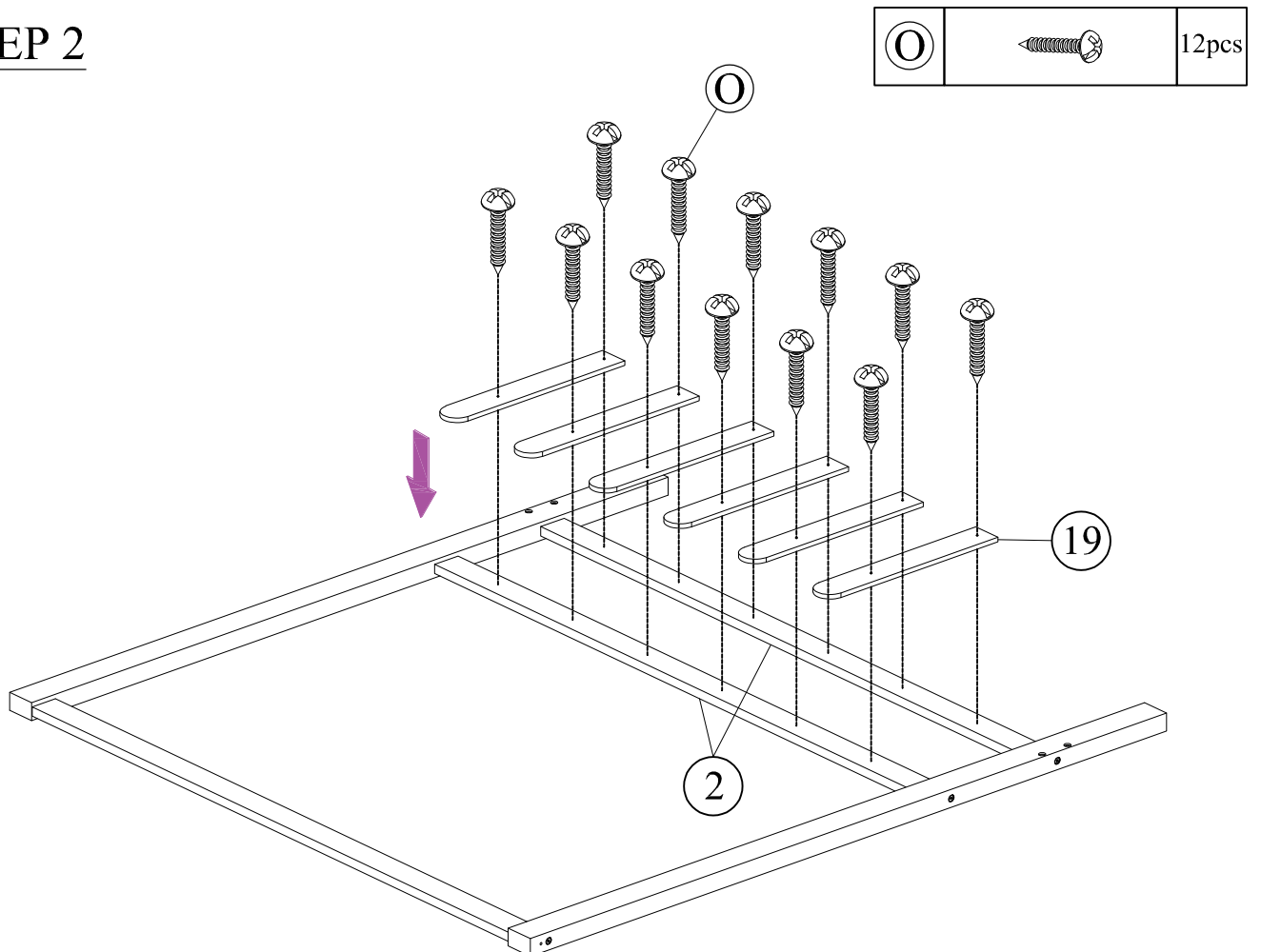

STEP 2



STEP 3

(A)		4pcs
(B)		4pcs
(I)		4pcs
(P)		1pc

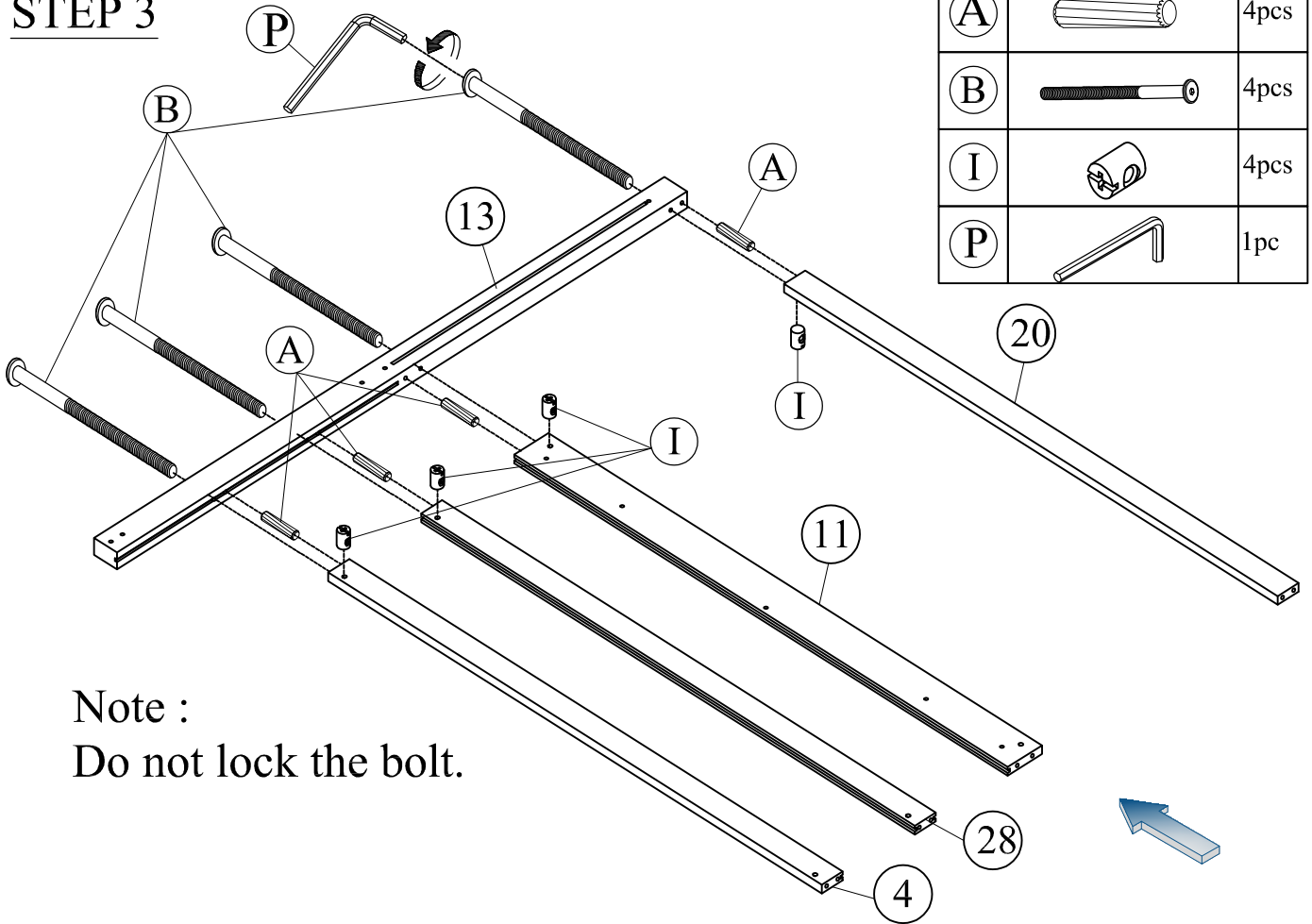

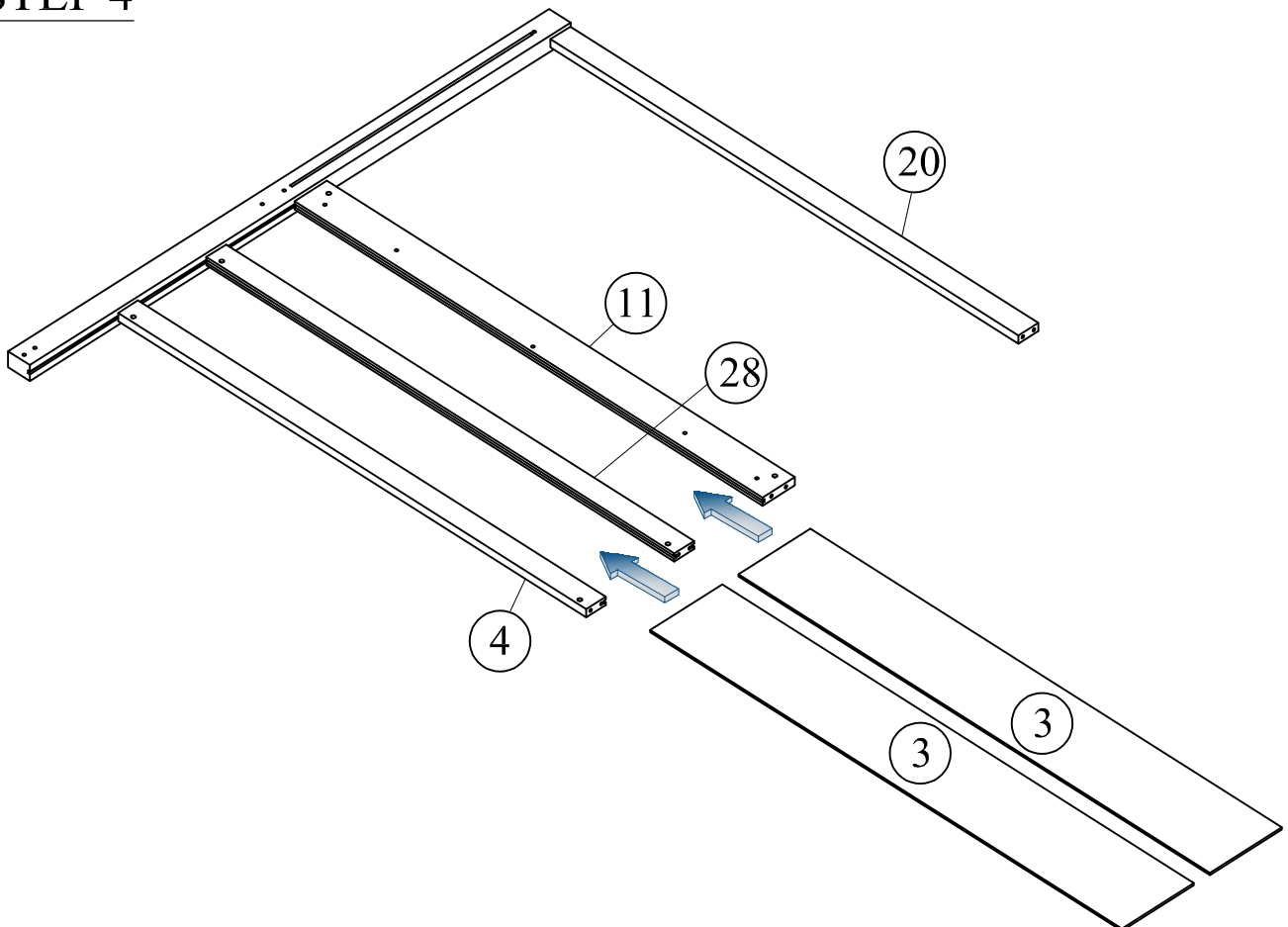

Note :
Do not lock the bolt.

STEP 4





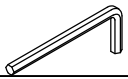

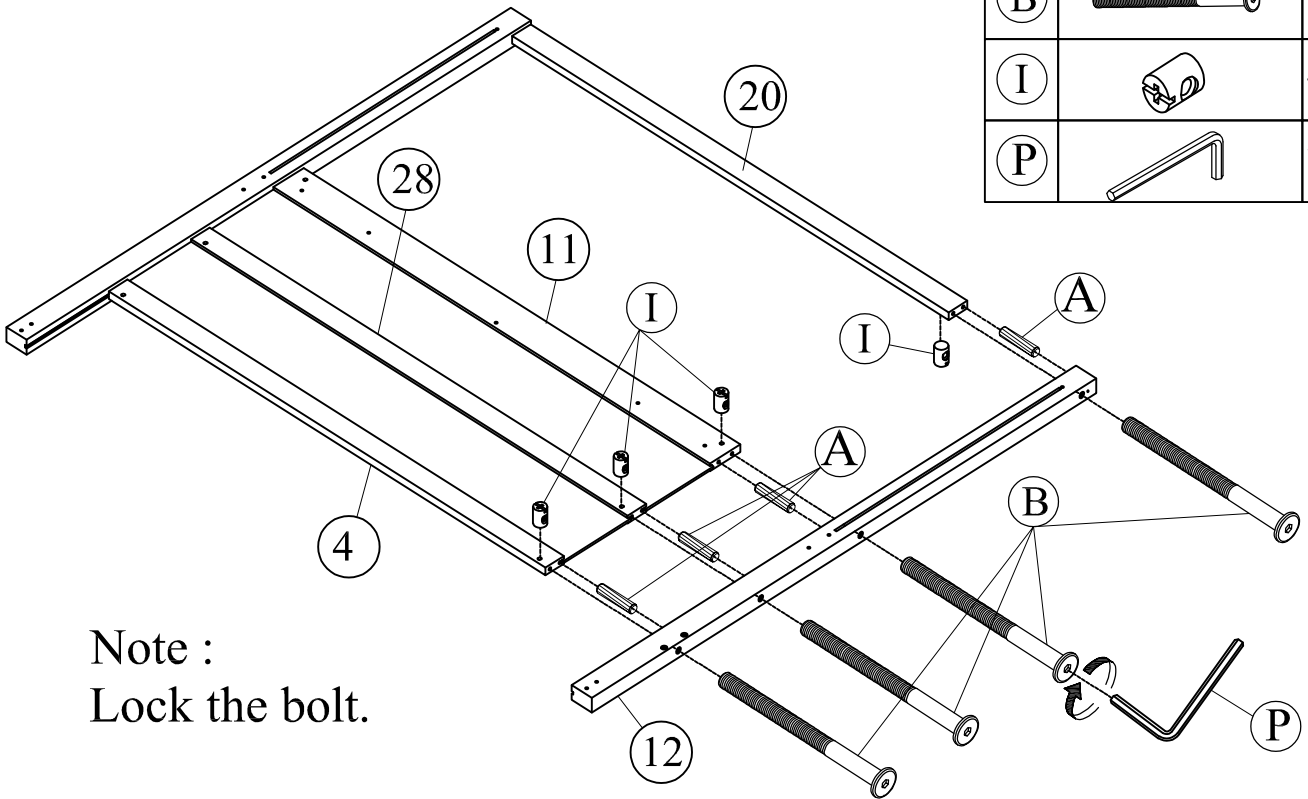
STEP 5

(A)		4pcs
(B)		4pcs
(I)		4pcs
(P)		1pc



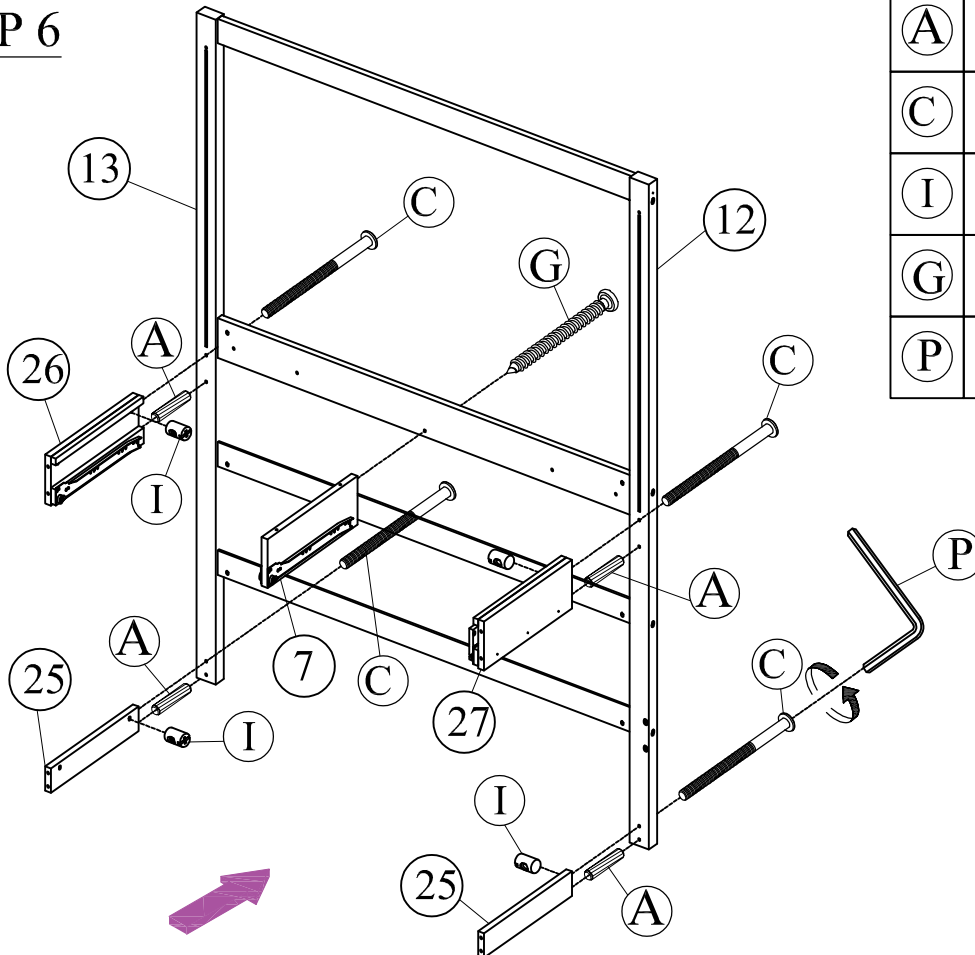

STEP 6

(A)		4pcs
(C)		4pcs
(I)		4pcs
(G)		1pc
(P)		1pc

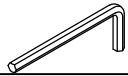

STEP 7

(A)		4pcs
(C)		4pcs
(I)		4pcs
(P)		1pc

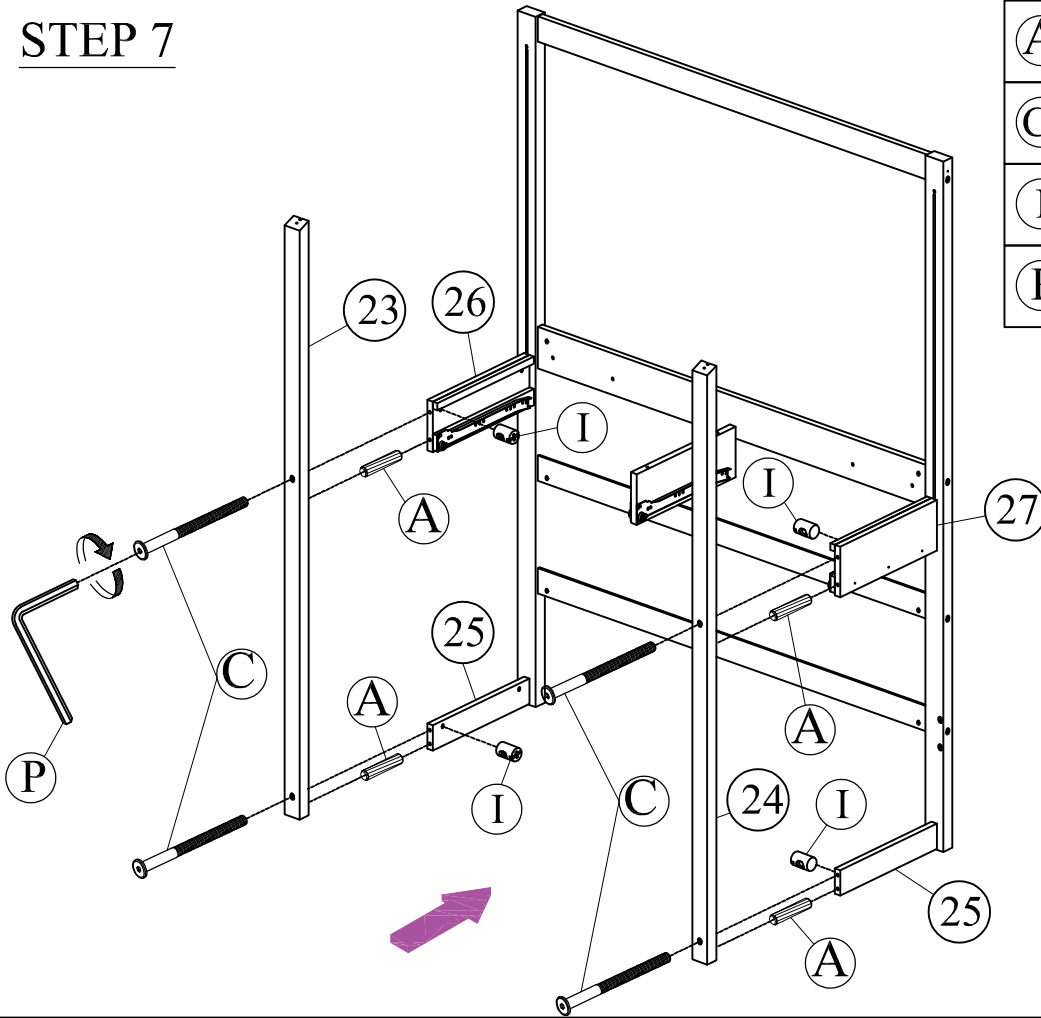

STEP 8

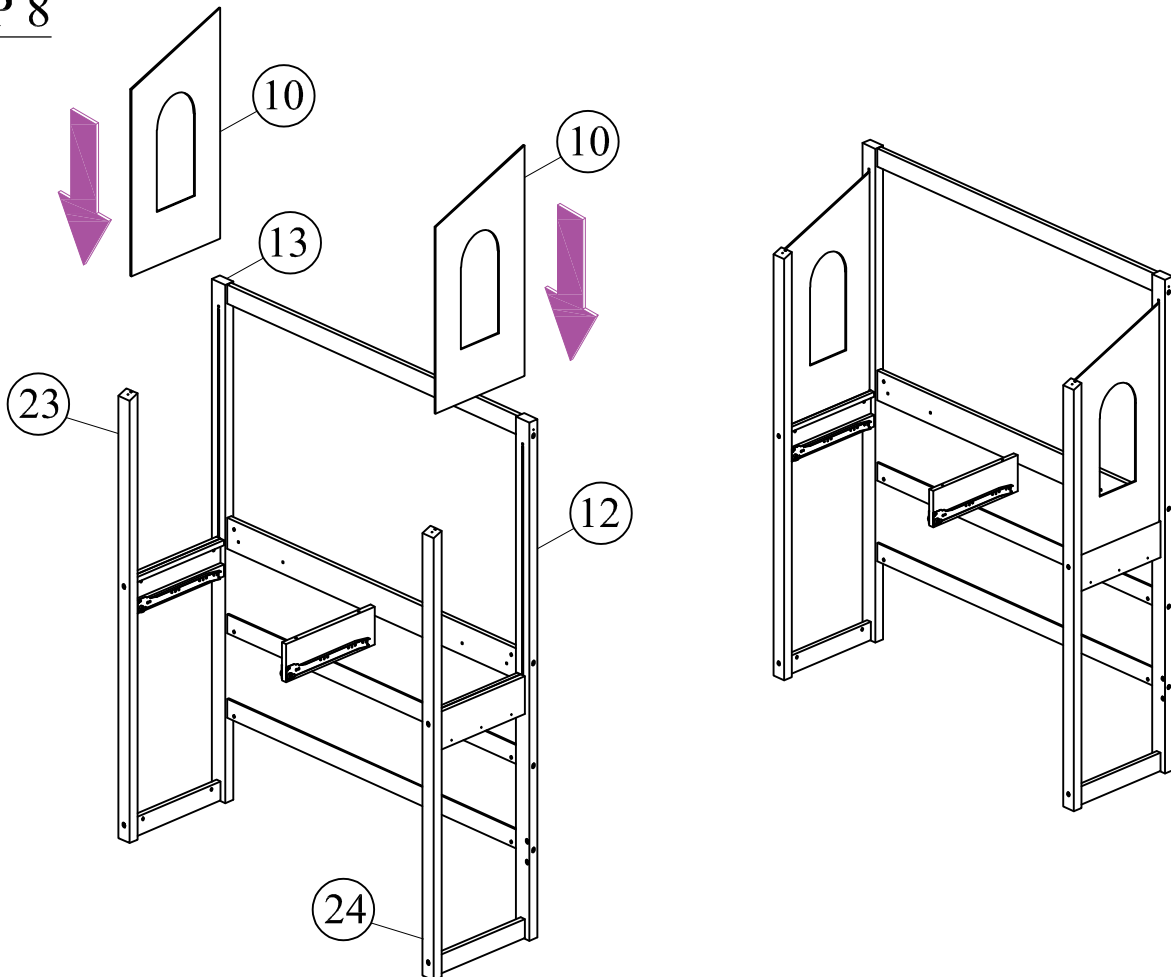

STEP 9

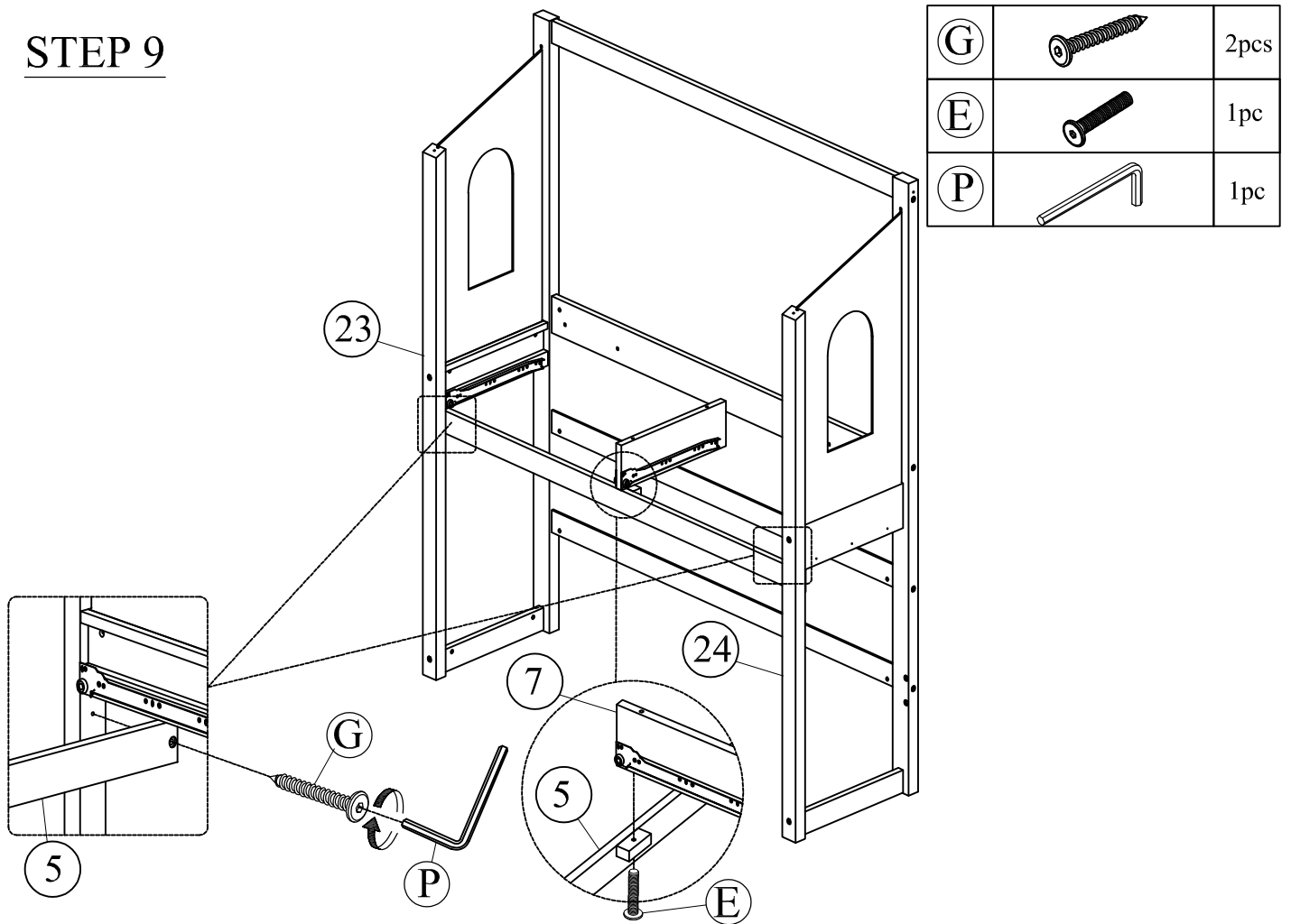

STEP 10

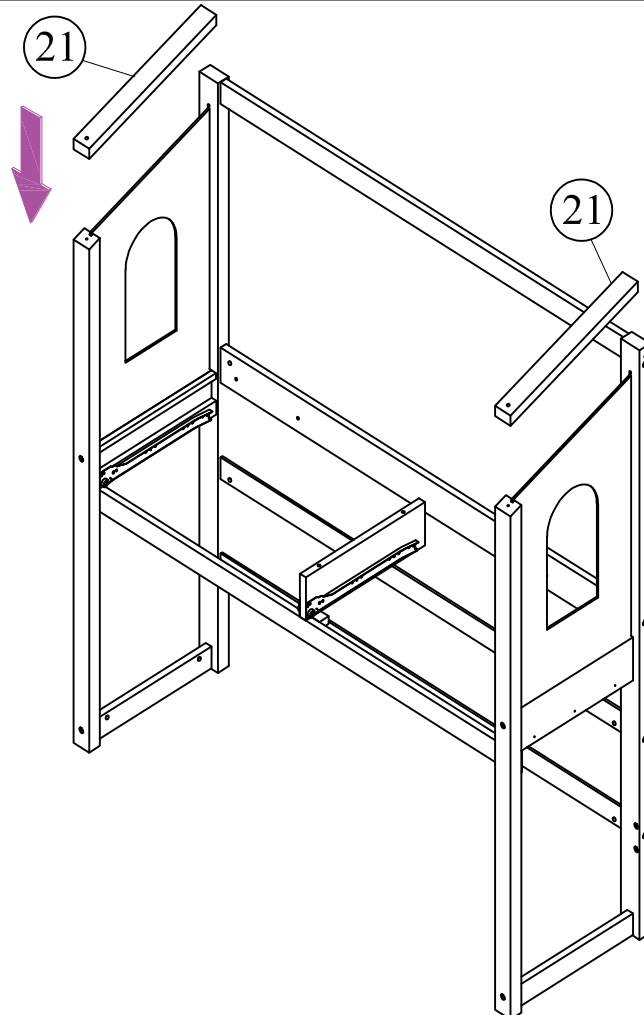

STEP 11

F		4pcs
---	---	------

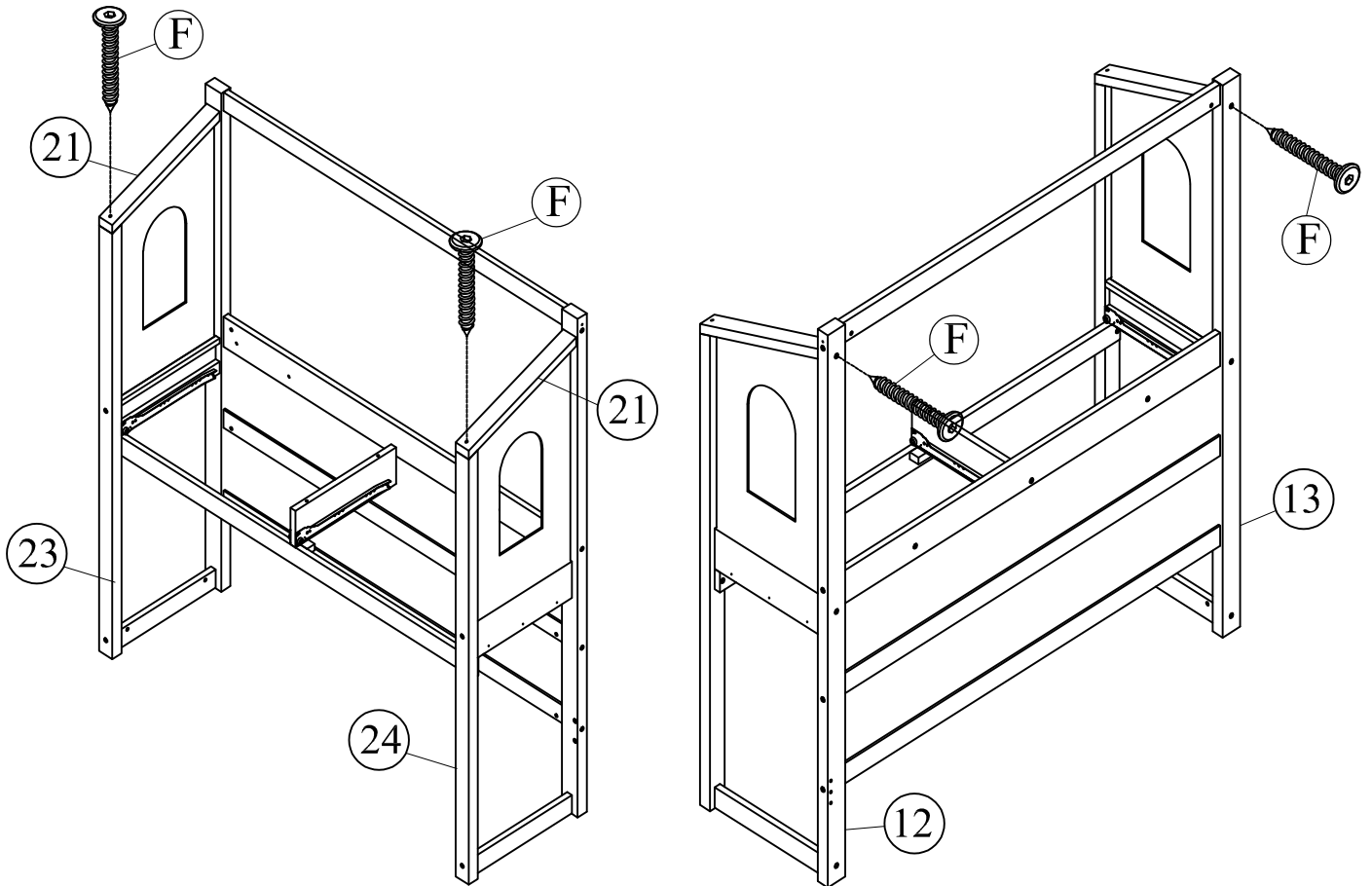

STEP 12

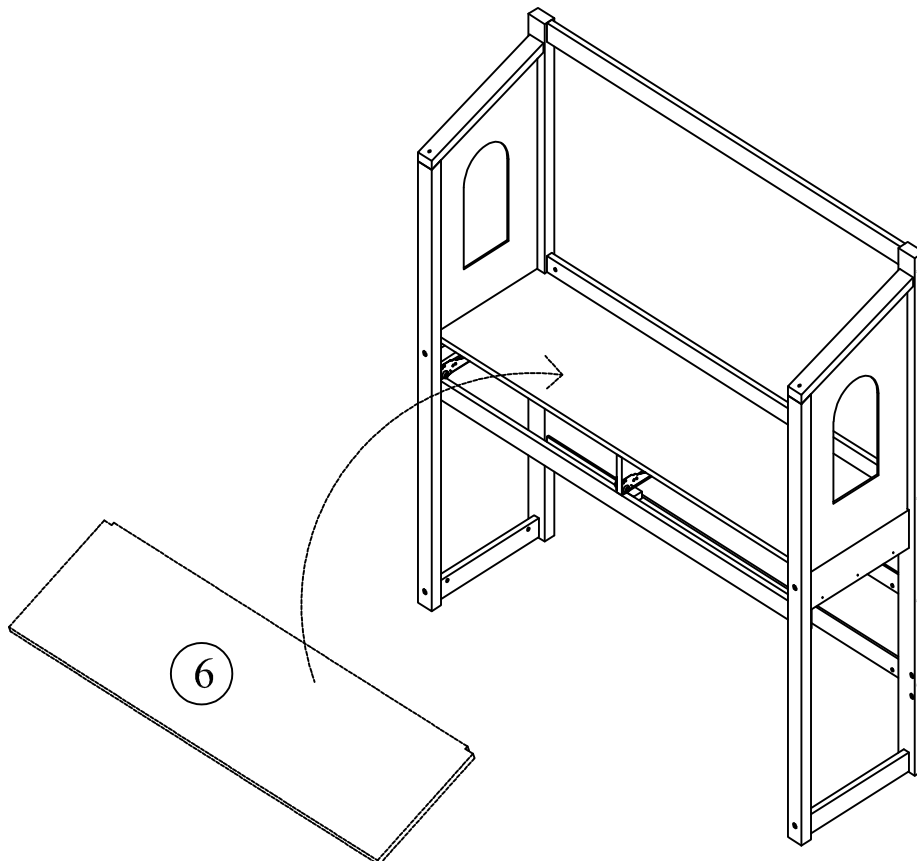

STEP 13

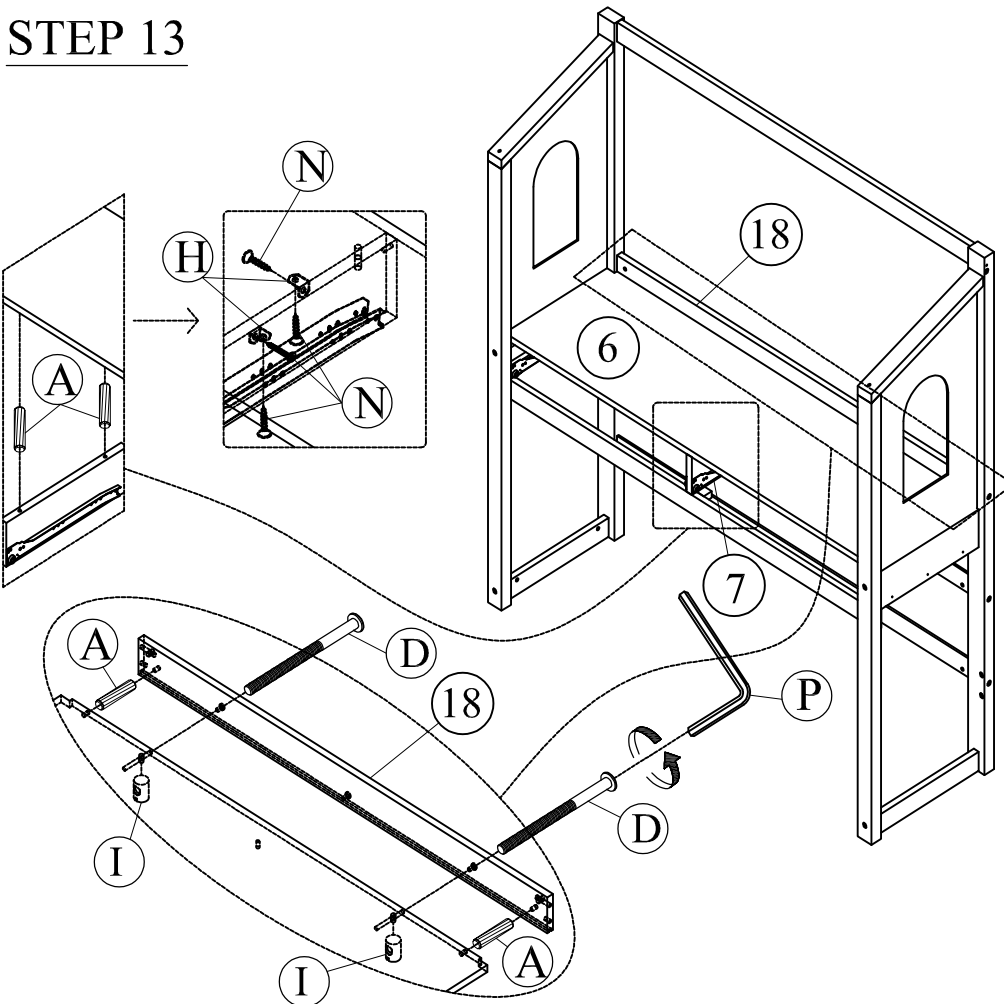

(A)		4pcs
(D)		2pcs
(I)		2pcs
(P)		1pc
(H)		2pcs
(N)		4pcs

STEP 14

(K)		8pcs
(J)		8pcs

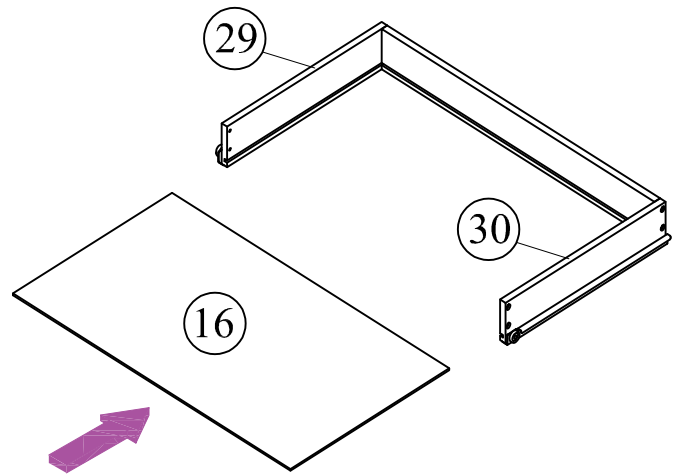
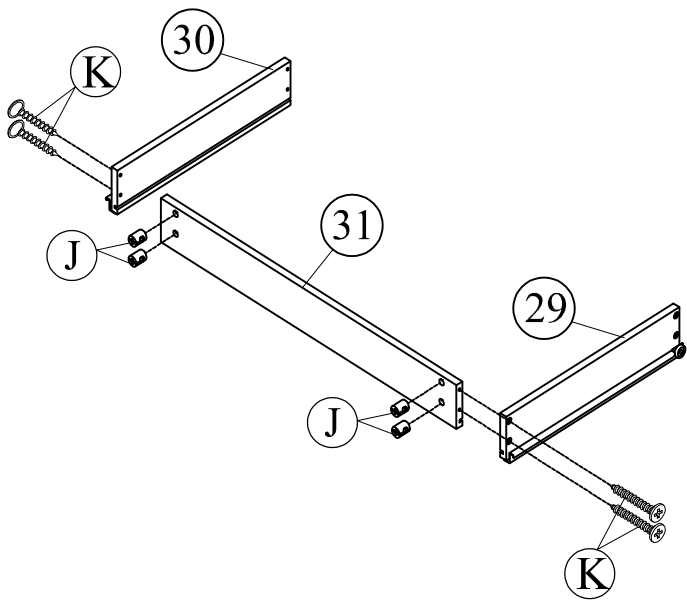

STEP 15



X2

X2

STEP 16

M		8pcs
Q		2pcs

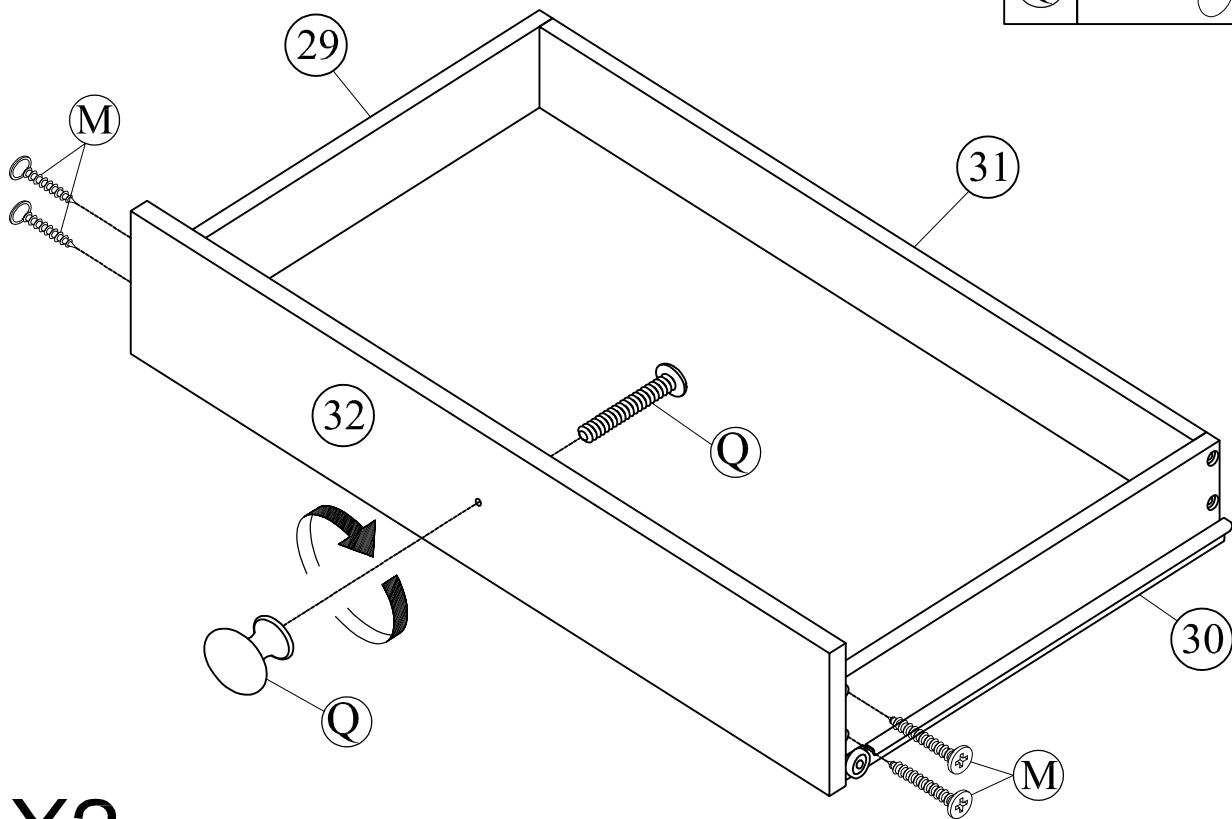



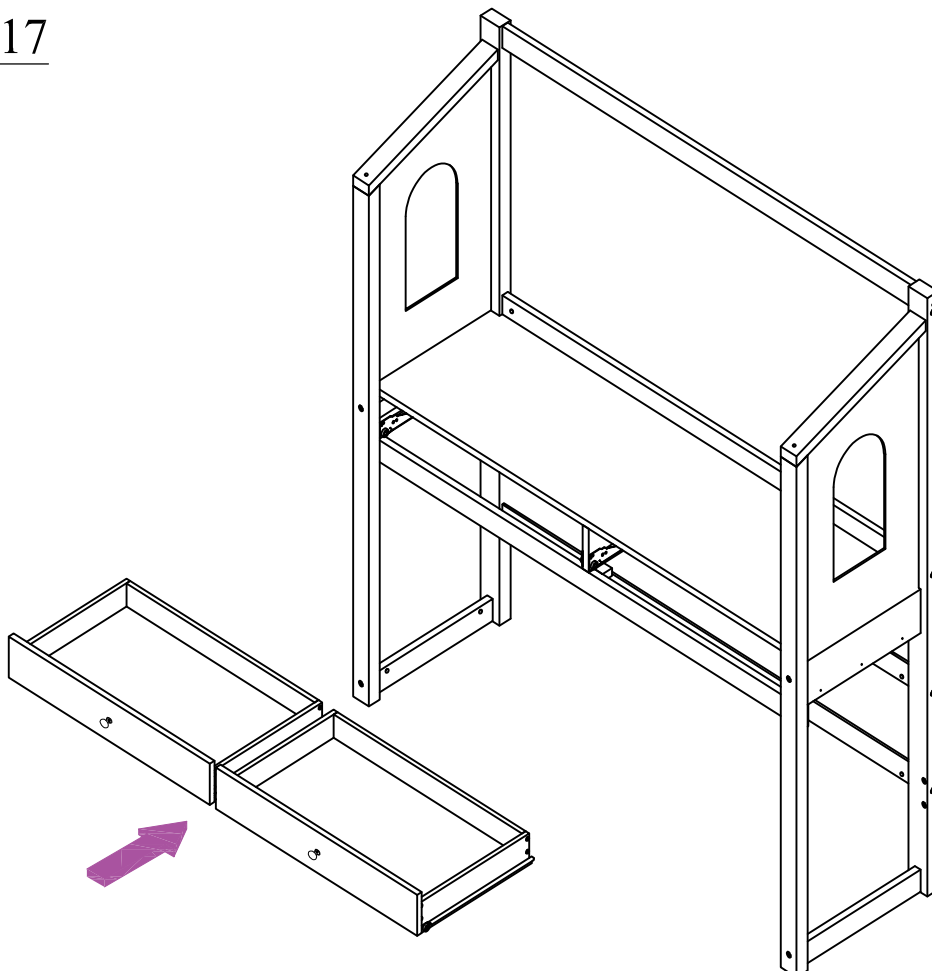

X2

STEP 17



STEP 18

(A)		4pcs
(C)		8pcs
(I)		8pcs
(P)		1pc

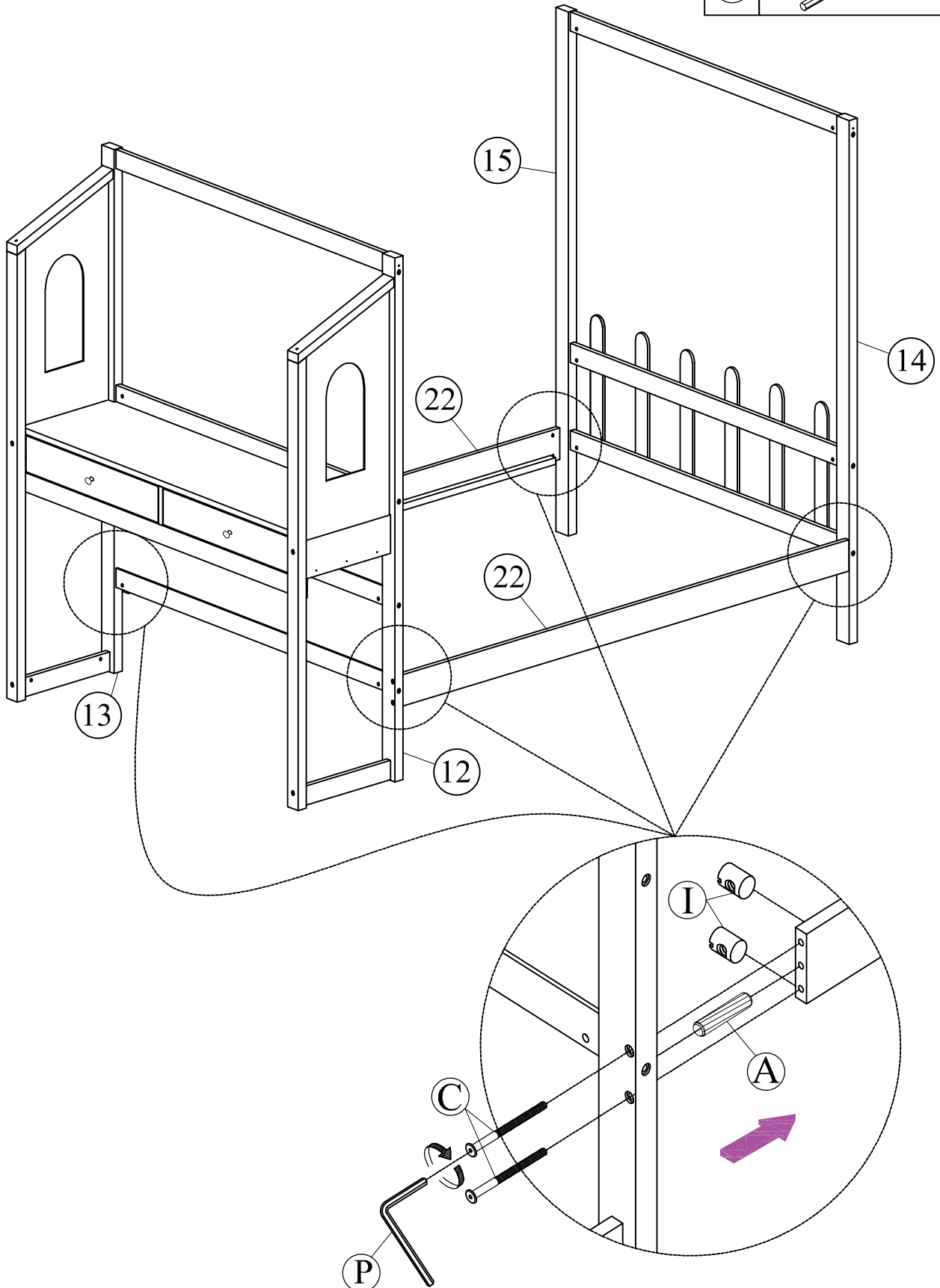





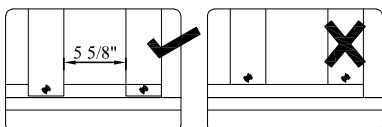
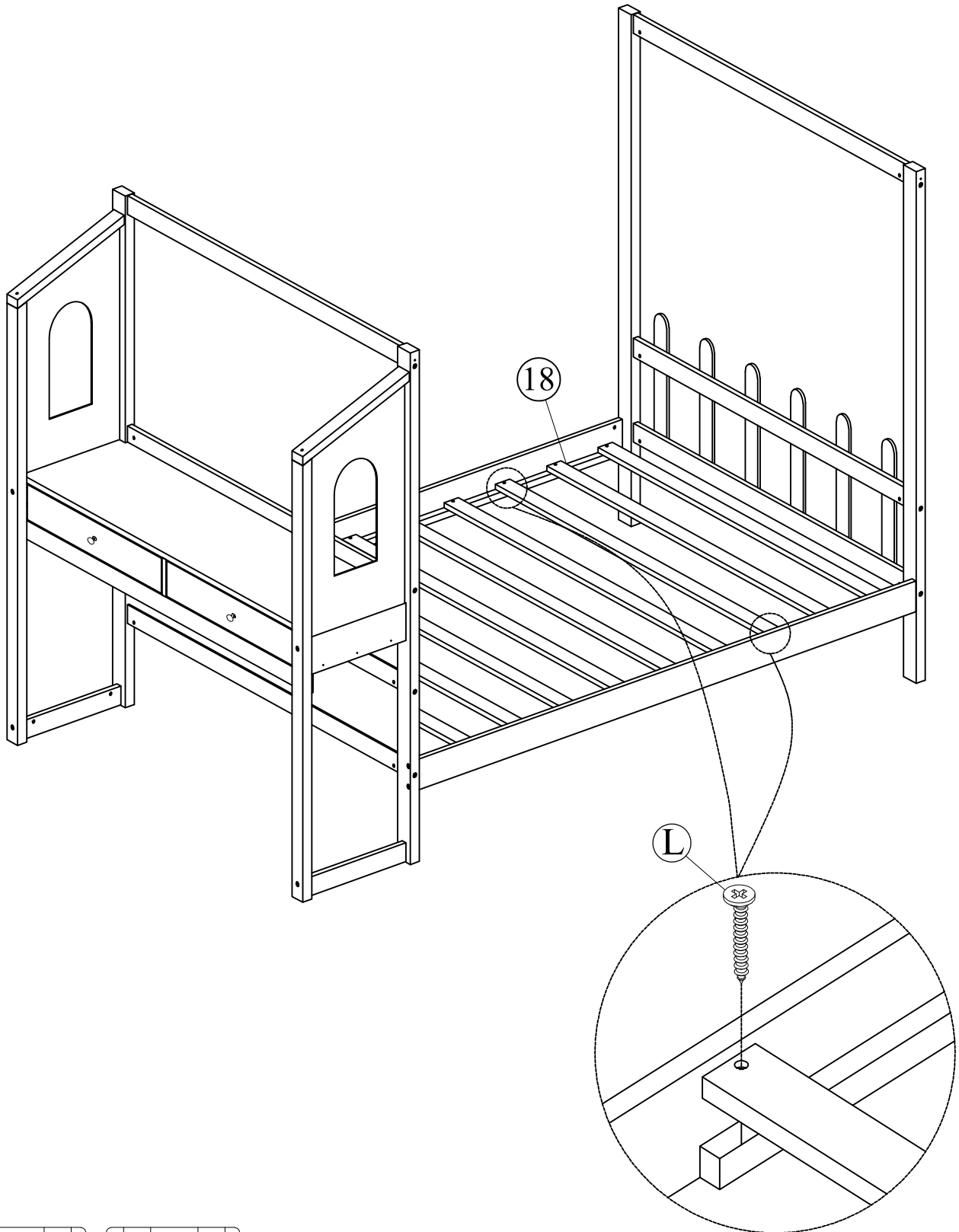

STEP 19

L		20pcs
---	---	-------

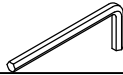

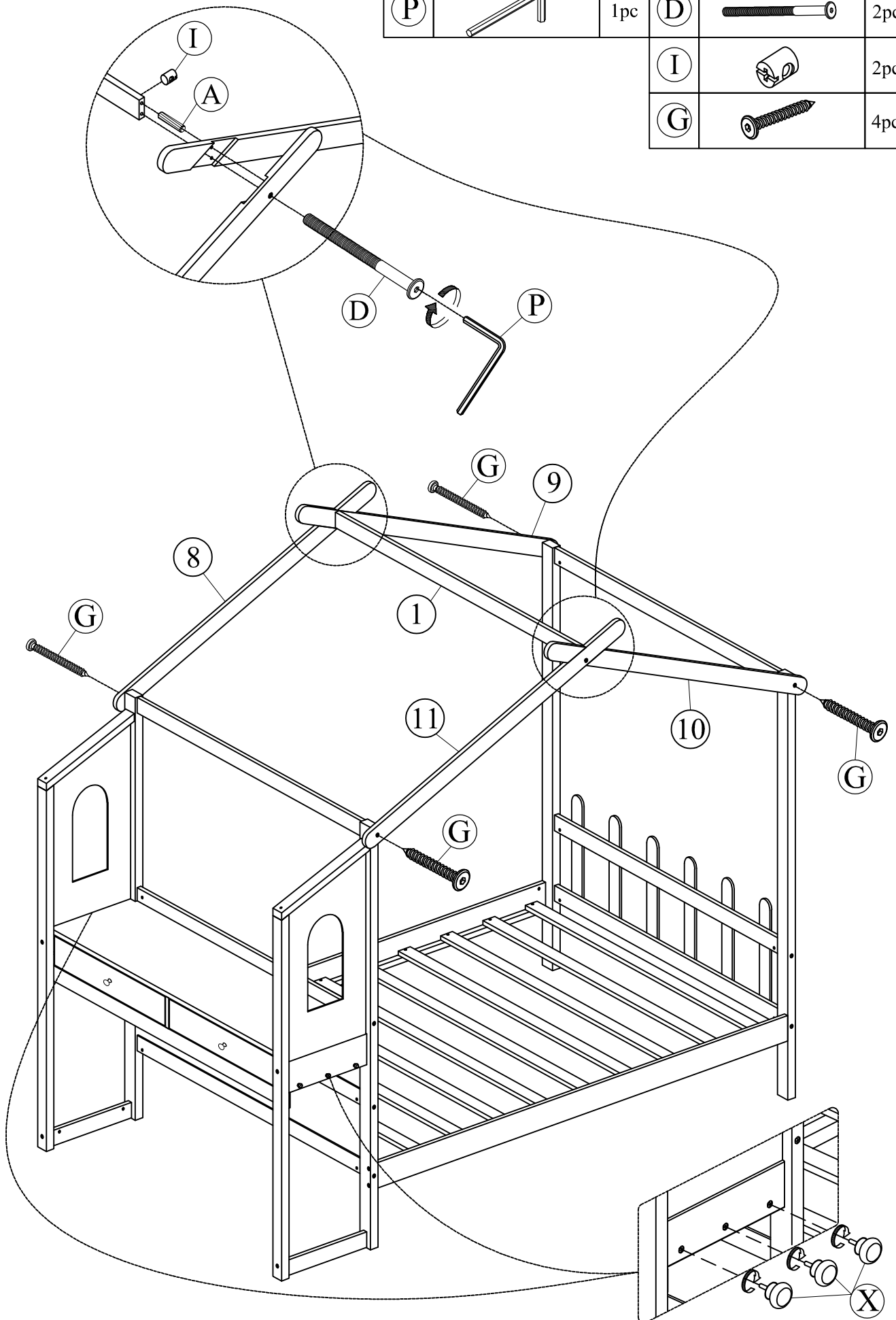

STEP 20

(X)		6pcs	(A)		2pcs
(P)		1pc	(D)		2pcs
			(I)		2pcs
			(G)		4pcs



STEP 21

(K)		8pcs
(J)		8pcs

