

Instruction Manual
Model # E114R

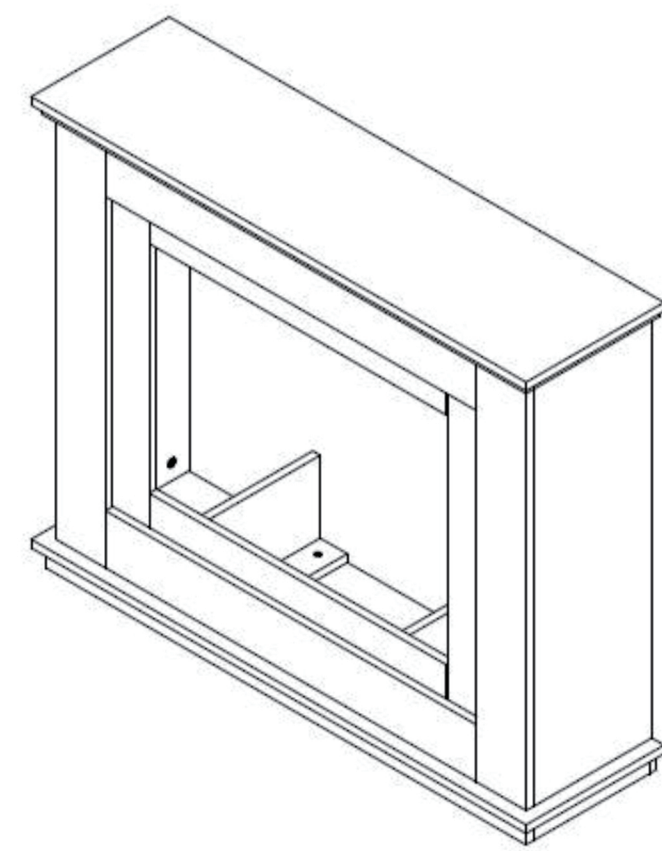

1

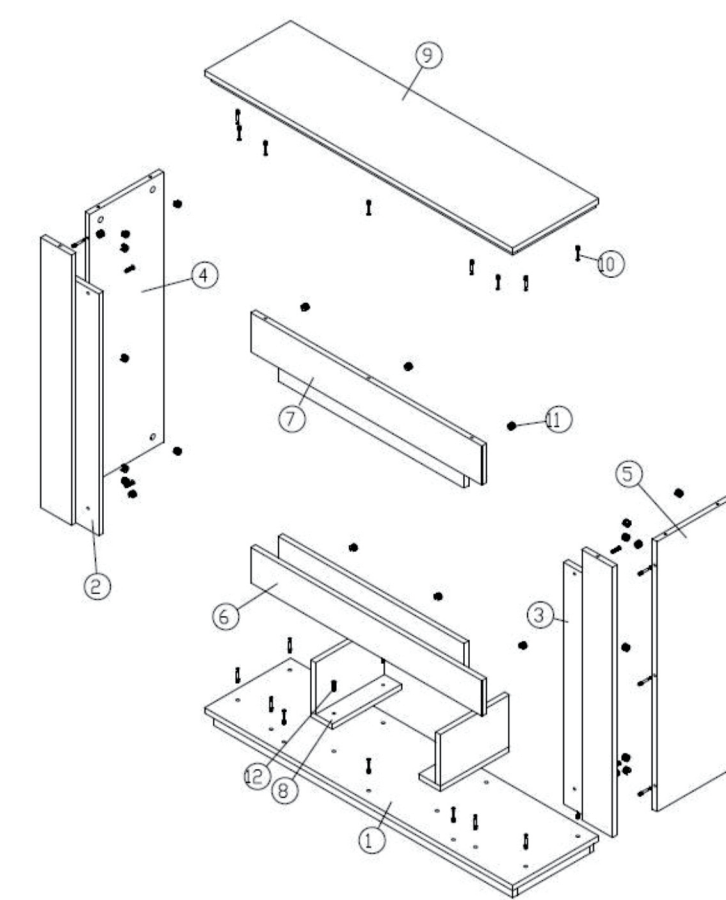





Assembly Parts

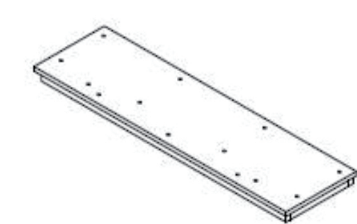
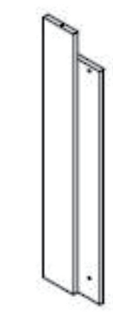
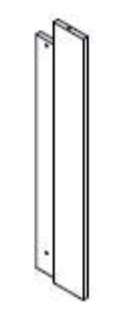

Parts List

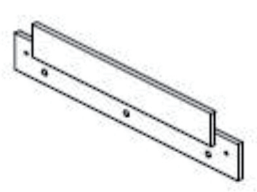
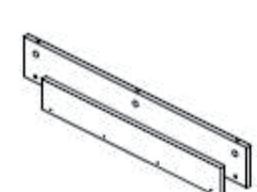
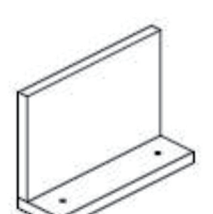
Please check packaging for all parts and hardware before discarding. Unpack and lay parts on clean, padded surface like carpet or blanket. Check that you have all parts indicated. Call customer service if hardware is missing. Before assembly, carefully study the diagrams below and sort your hardware according to the pictures. Using the incorrect hardware will cause damage.

2

① Quantity Of 1  Base	② Quantity Of 1  Left Front Panel	③ Quantity Of 1  Right Front Panel
④ Quantity Of 1  Left Side Panel	⑤ Quantity Of 1  Right Side Panel	⑥ Quantity Of 1  Lower Front Panel
⑦ Quantity Of 1  Upper Front Panel	⑧ Quantity Of 2  Support Panel	⑨ Quantity Of 1  Top Panel
⑩ Quantity Of 24  Cam Bolt	⑪ Quantity Of 24  Cam Lock	⑫ Quantity Of 8  Bolt Dia. 6x25mm

3

Assembly Instructions

Fig.1

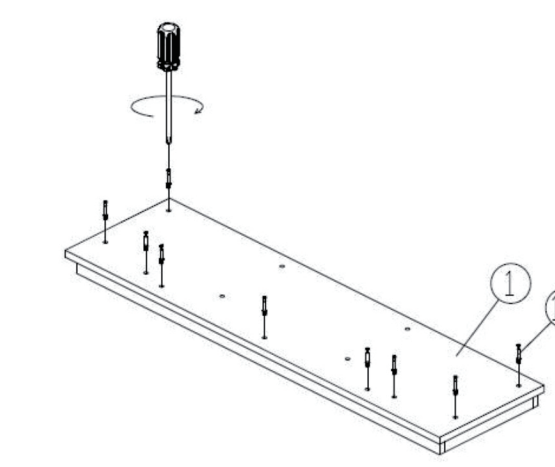

Screw Cam Bolts ⑩ into holes on Base ①.

"Please do not over tighten cam bolts, please stop when you feel tight"

Fig.2

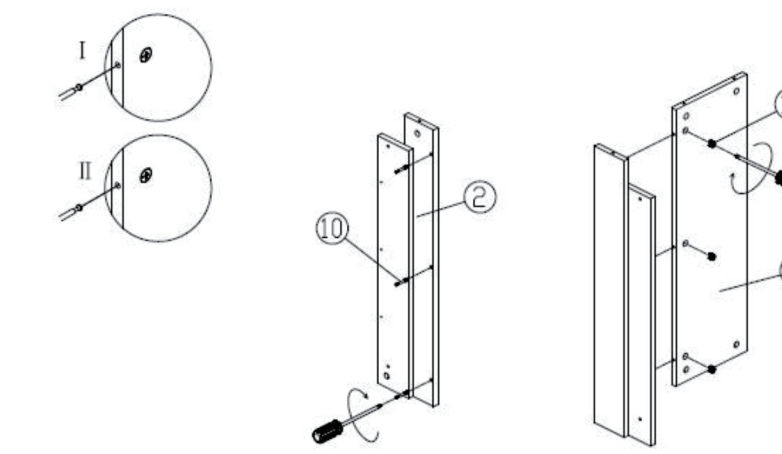

1. Screw Cam Bolts ⑩ into holes on Left Front Panel ②.
2. Insert cam Bolts into holes on Left Side Panel ④.
Tighten by rotating Cam Lock ⑪ clockwise with screwdriver.

4

Fig.3

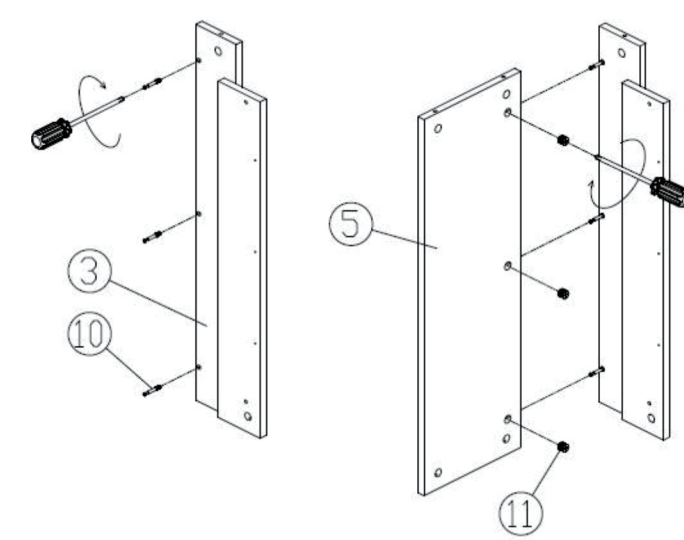

1. Screw Cam Bolts ⑩ into holes on Right Front Panel ③.
2. Insert Cam Bolts into holes on Right Side Panel ⑤.
Tighten by rotating Cam Locks ⑪ clockwise with screwdriver.

Fig.4

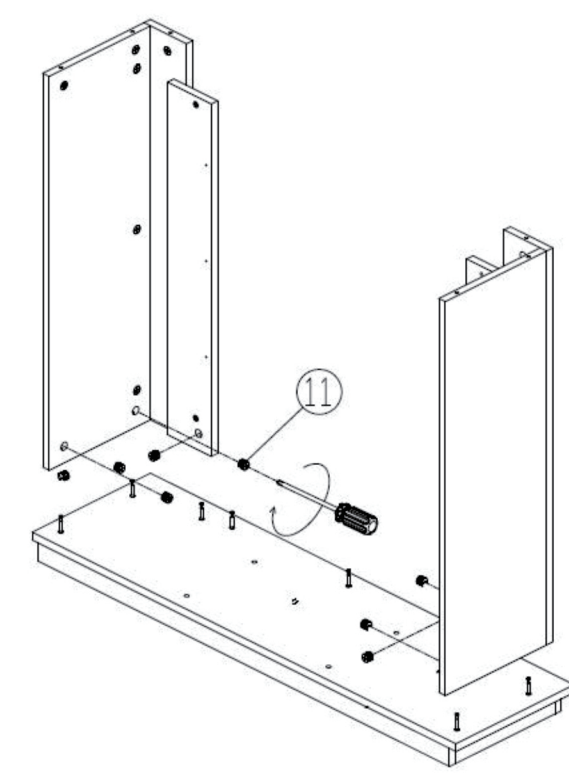

1. Attach assembly unit on Fig.2 and assembly unit on Fig.3 to Base assembly unit on Fig.1 by inserting Cam Bolts into corresponding holes until Base.
2. Tighten by rotating Cam Locks ⑪ clockwise with screwdriver.

5

Fig.5

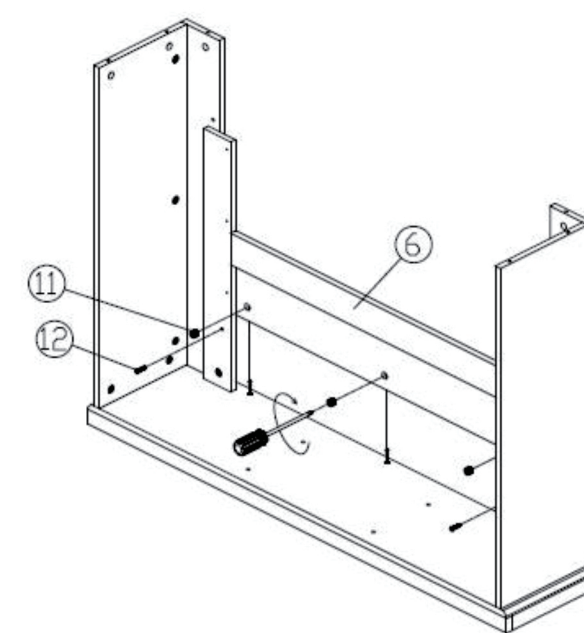

1. Insert Cam bolts into holes on Lower Front Panel ⑥.
Tighten by rotating Cam Locks ⑪ clockwise with screwdriver.
2. Connect Lower Front Panel to Left Front Panel and Right Front Panel by Bolts ⑫.

Fig.6

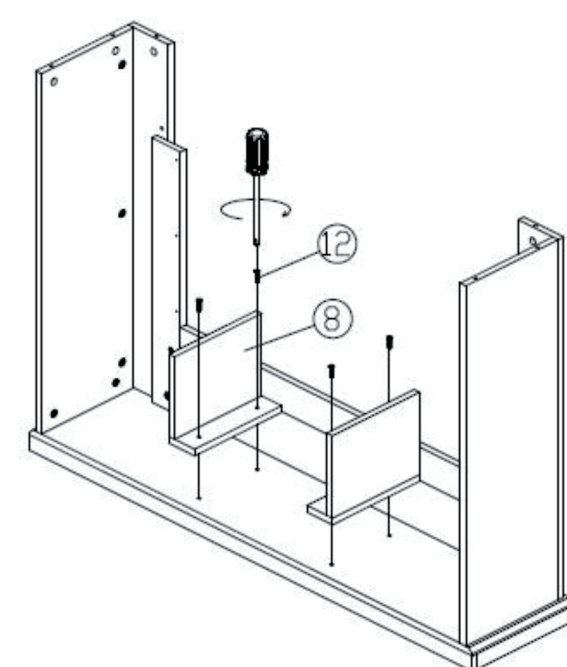

Screw 2 pieces of Support Panels ⑧ into holes on Base by Bolts ⑫.

6

Fig.7

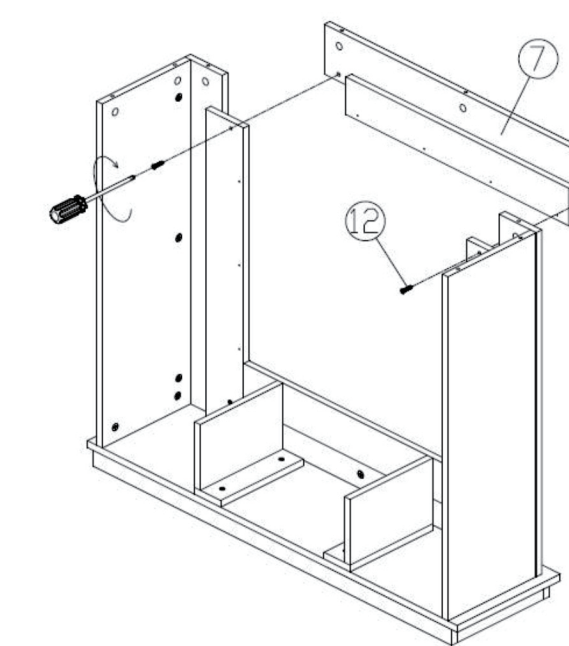

2. Connect Upper Front Panel ⑦ to Left Front Panel and Right Front Panel by bolts ⑫.

Fig.8

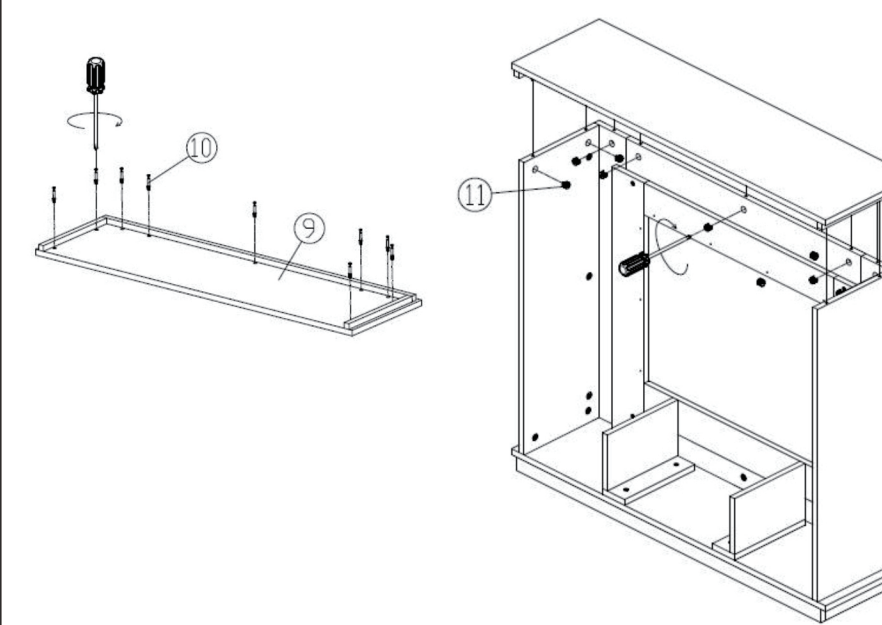

1. Screw Cam Bolts ⑩ into holes on Top Panel ⑨.
2. Insert Cam Bolts into holes on the top edges of the assembly unit on Fig.7.
3. Tighten by rotating Cam Lock ⑪ clockwise with screwdriver.

7