

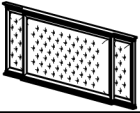

# ASSEMBLY INSTRUCTION





## DESCRIPTION : KING HEADBOARD W/LED LIGHT

Thank you for purchasing this quality product. Be sure to check all packing material carefully for small parts which may have loose inside the carton during shipment. Identify and count all parts and compare with the parts list below.

### PART LIST#

NO	NAME	PART	QTY
A	Headboard		1pc
B	Headboard Post - (L/R)		2pcs

### HARDWARE LIST#

NO	NAME	PART	QTY
1	Allen key		1pc
2	JCBC 40mm		6pcs
3	M6 Spring washer		6pcs
4	M6 Flat washer		6pcs
5	AC/DC Adapter		1pc
<b>HARDWARE LOCATED IN HEADBOARD BOX</b>			

## STEP 1 :

### 3 OPTIONS HEIGHT POSITION OF HEADBOARD

#### #OPTION 1

ADJUST HEADBOARD TO FIT 8" MATTRESS

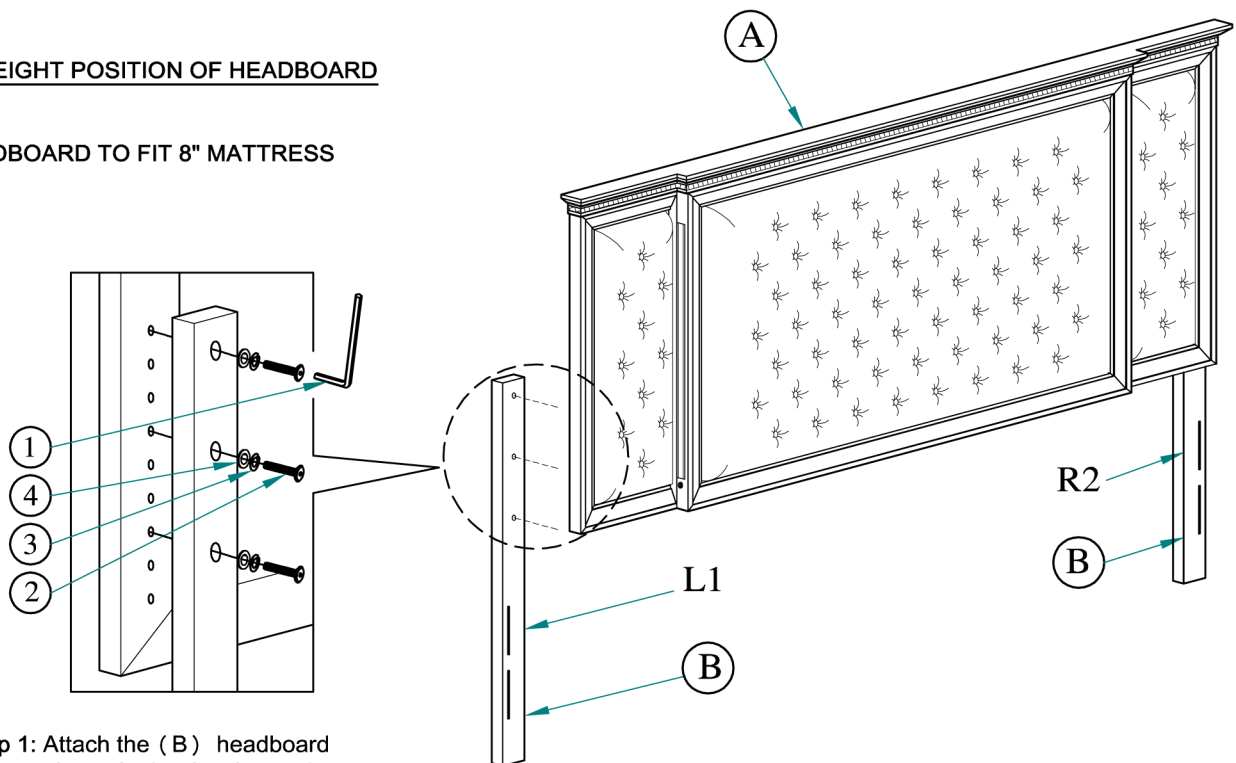

Step 1: Attach the ( B ) headboard post as shown in the drawing and tighten with ( 2 ) JCBC 40mm , ( 3 ) M6 spring washer & ( 4 ) M6 flat washer.

**#OPTION 2  
ADJUST HEADBOARD TO FIT 10" MATTRESS**

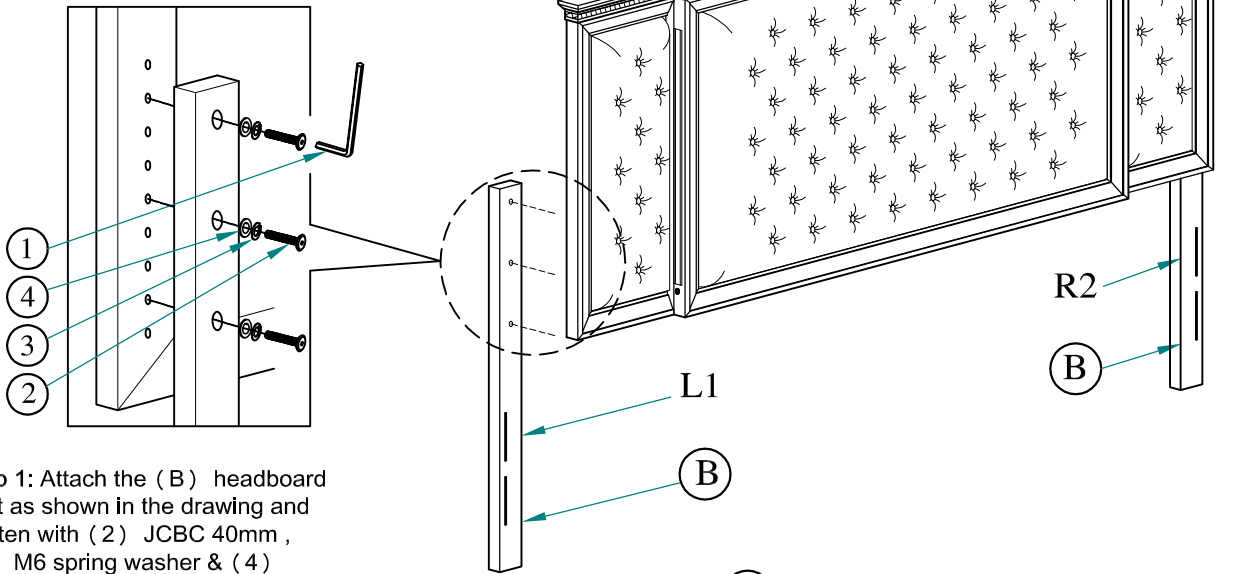

**Step 1:** Attach the (B) headboard post as shown in the drawing and tighten with (2) JCBC 40mm , (3) M6 spring washer & (4) M6 flat washer.

**#OPTION 3  
ADJUST HEADBOARD TO FIT 12" MATTRESS**

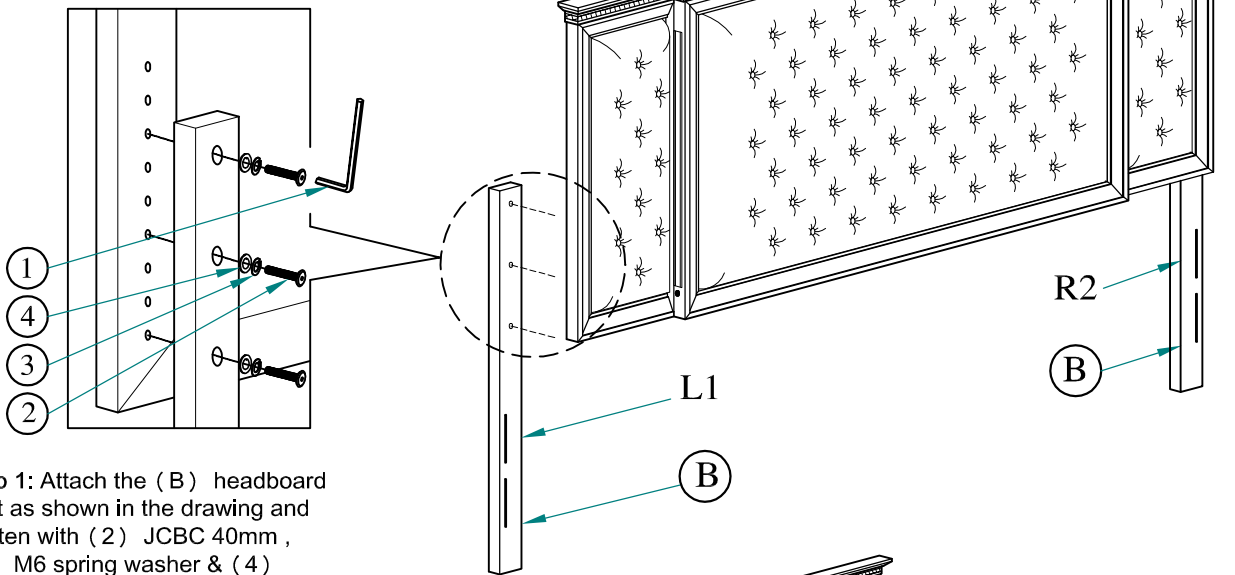

**Step 1:** Attach the (B) headboard post as shown in the drawing and tighten with (2) JCBC 40mm , (3) M6 spring washer & (4) M6 flat washer.

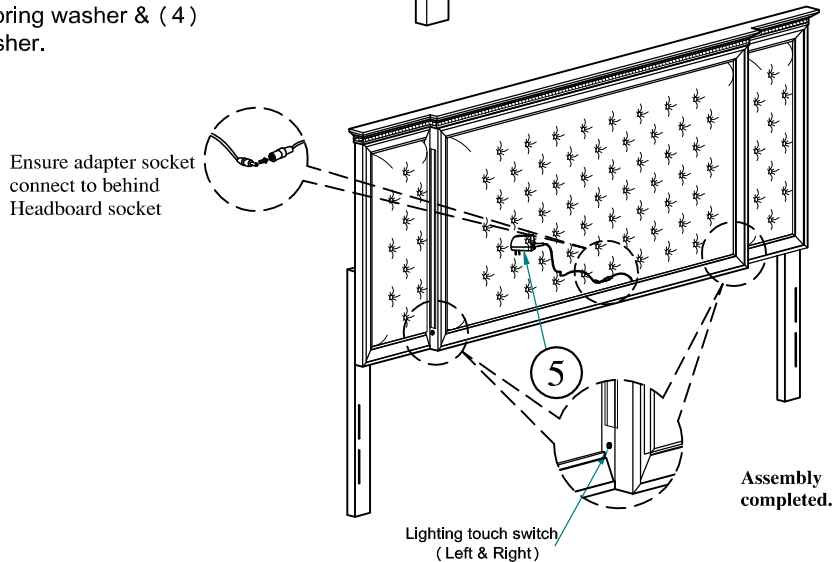

Ensure adapter socket connect to behind Headboard socket

Lighting touch switch (Left & Right)









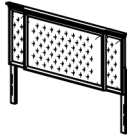

**Assembly completed.**

# ASSEMBLY INSTRUCTION

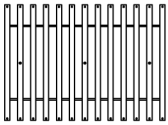

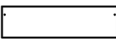

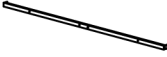



## DESCRIPTION : KING BED WITH 13 SLATS

Thank you for purchasing this quality product. Be sure to check all packing material carefully for small parts which may have loose inside the carton during shipment. Identify and count all parts and compare with the parts list below.

### PART LIST#

NO	NAME	PART	QTY
A	Headboard		1pc
B	Footboard		1pc
C	Side Rail		2pcs
D	Drawer		2pcs
E	Drawer Base Panel		2pcs
F	Roll Slat		13pcs
G	Slat Support Leg		3pcs
H	Drawer Support Leg		1pc
I	Slat Cover Panel		1pc
J	Center Vertical Slat		1pc
K	Drawer Support Rail		1pc
L	Bun Foot		2pcs

### HARDWARE LIST#

NO	NAME	PART	QTY
1	Allen key		1pc
2	JCBC 16mm		2pcs
3	JCBC 35mm		9pcs
4	JCBC 60mm		3pcs
5	M6 Spring washer		14pcs
6	M6 Flat washer		11pcs
7	Screw 32mm		26pcs
8	Screw 16mm		2pcs
9	Adjustable Leveller		4pcs
<b>HARDWARE LOCATED IN FOOTBOARD BOX</b>			

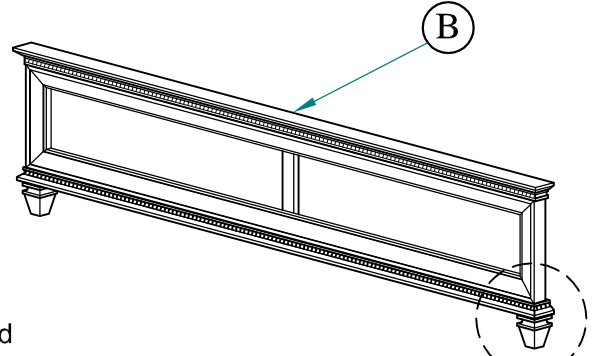

Step 1:  
Secure the (L) Bun Foot to  
the bottom of (B) Footboard  
as a diagram shown.

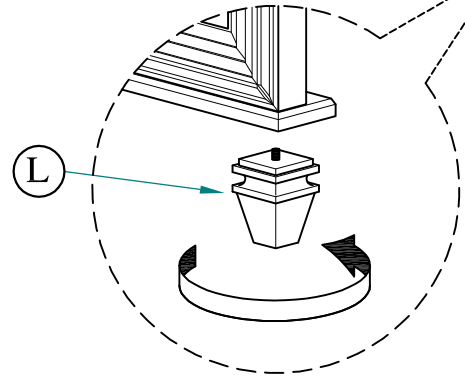
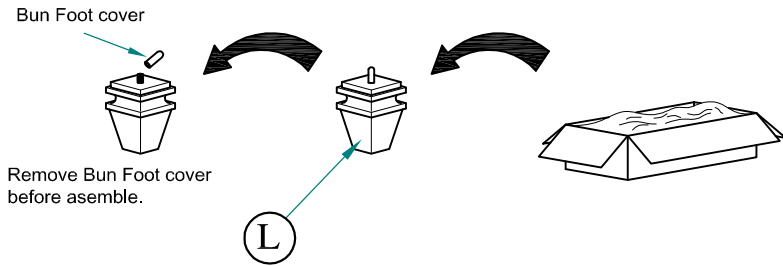

Step 2 :  
Attach the (C) Side Rail to the  
(A) Headboard & (B) Footboard.

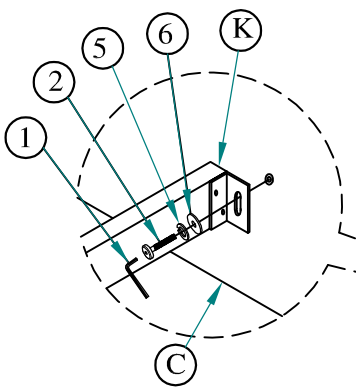
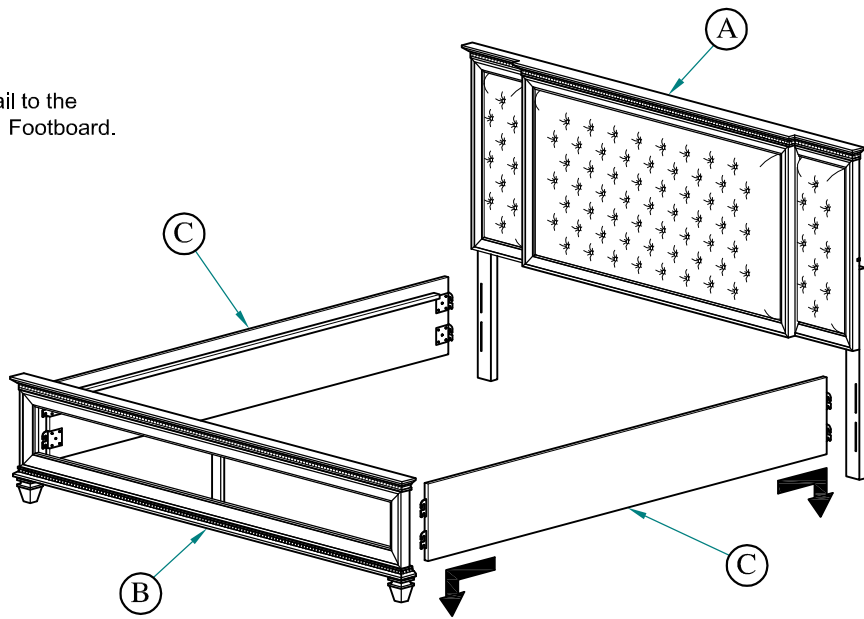

Step 3 :  
Attach the (K) Drawer Support Rail  
to the (C) Side Rail as a diagram  
shown tighten with (2) JCBC 16mm,  
(5) M6 Spring Washer & (6) M6 Flat Washer.

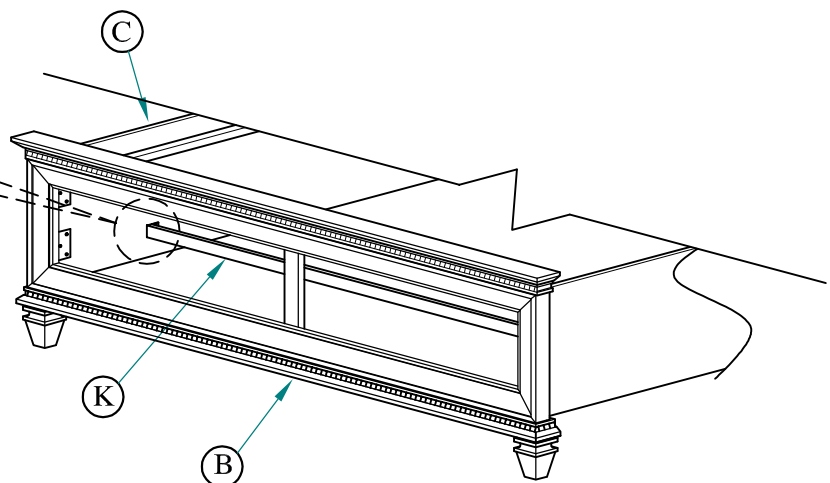

Step to remove the drawer :

1. Pull the drawer
2. Using both hands,
  - Left hands side - pull up switch
  - Right hands side - pull down switch
3. Then remove the drawer from the drawer base panel

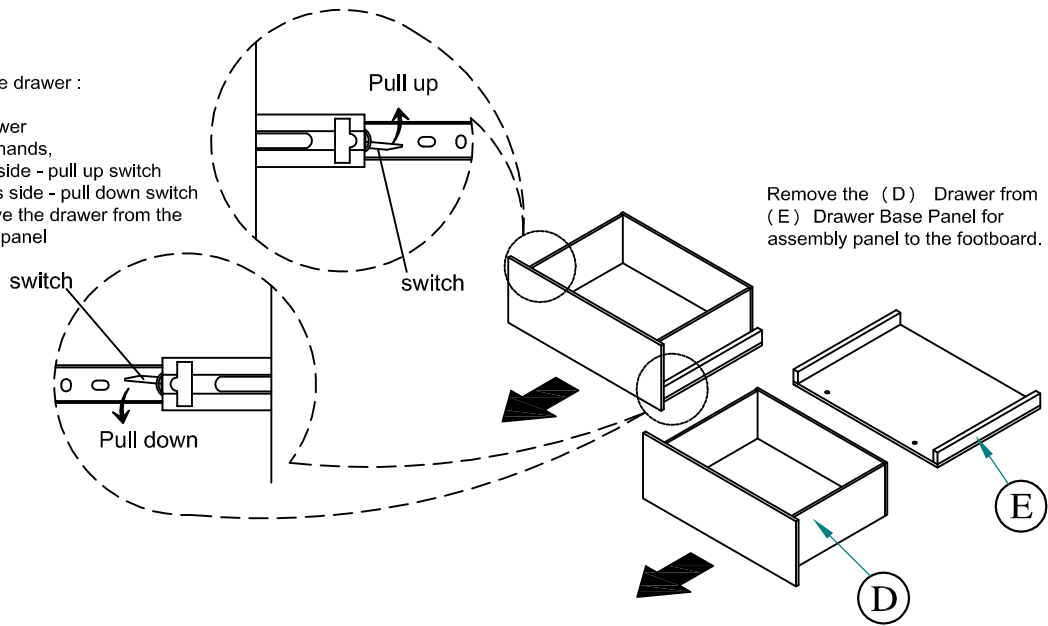

Remove the (D) Drawer from (E) Drawer Base Panel for assembly panel to the footboard.

**Step 4 :**

Attach (E) Drawer Base Panel to the (B) Footboard as diagram shown and tighten using (3) JCBC 35mm, (5) M6 Spring Washer & (6) M6 Flat Washer.

**Step 5 :**

Tighten the (E) Drawer Base Panel to the (K) Drawer Support Rail Panel as diagram shown using the (3) JCBC 35mm, (5) M6 Spring Washer & (6) M6 Flat Washer.

**Step 6 :**

Attach (H) Drawer Support Leg to the (K) Drawer Support Rail using (3) JCBC 35mm, (5) M6 Spring Washer & (6) M6 Flat Washer. Attach the (9) Adjustable Leveller and adjust it to level the bed with the floor.

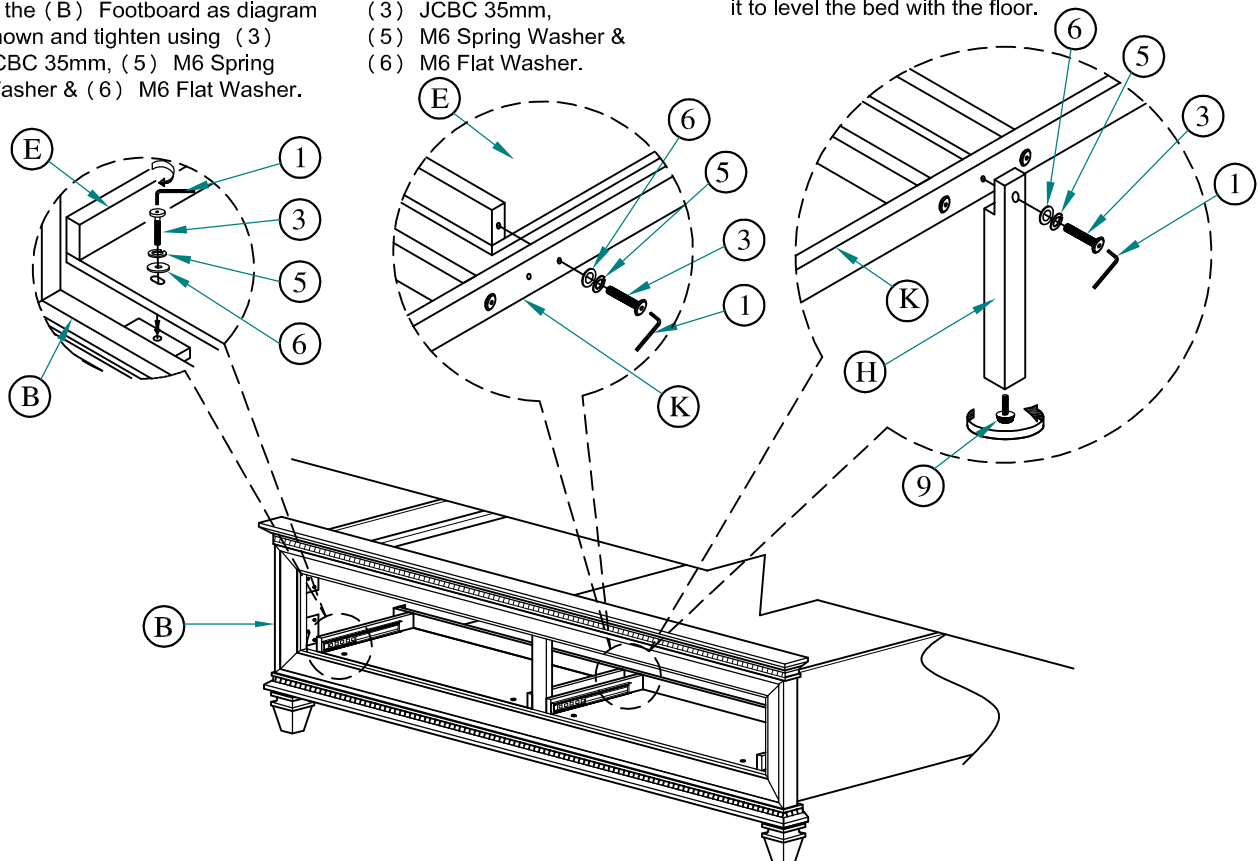

Step to install the drawer on the drawer base panel :

\*\*\*Prefer 2 person to install the drawer

1. Adjust the ball bearing plate to the front as a diagram shows.
2. Then attach the drawer to the drawer base panel and install with carefully.

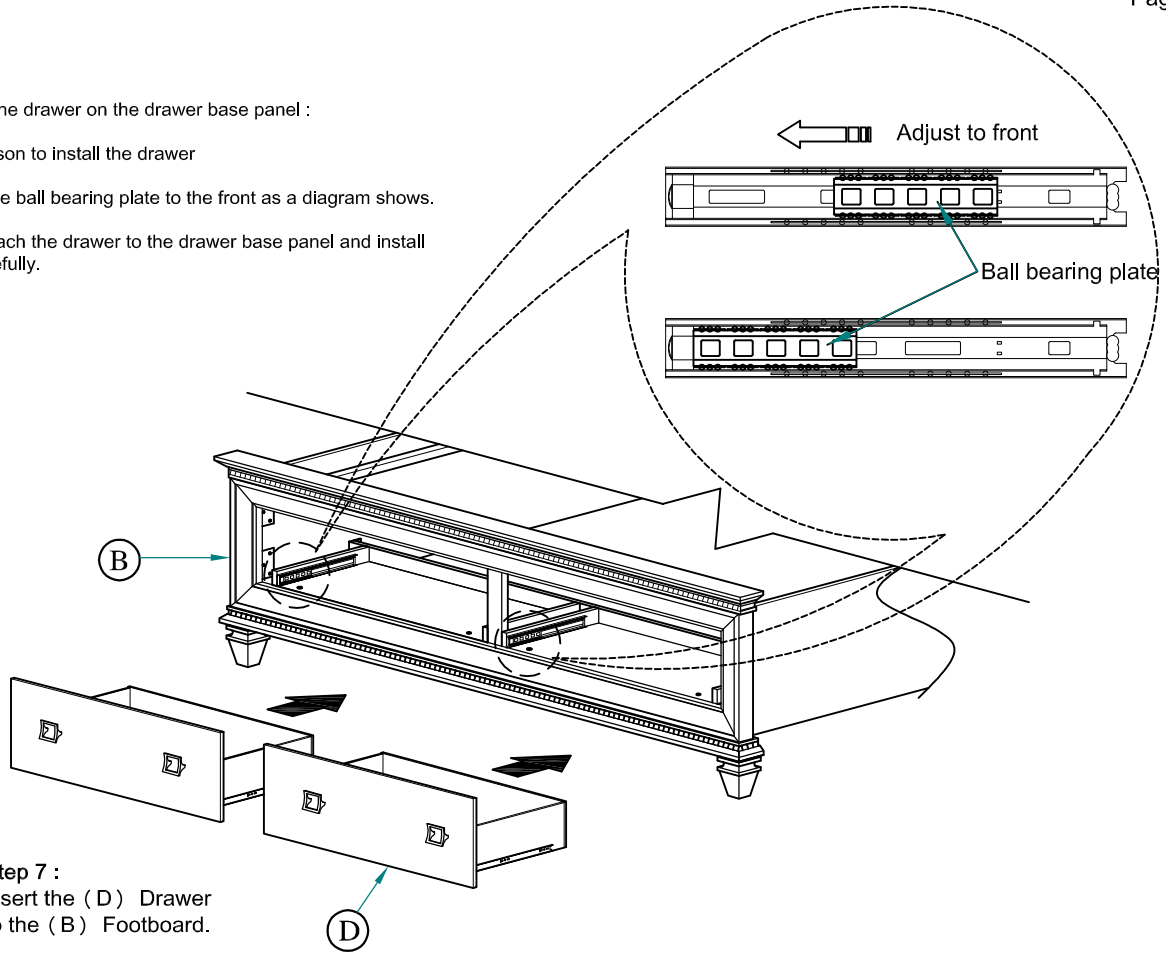

**Step 8 :**

Secure the (F) Roll Slat using the (7) Screw 32mm provided.

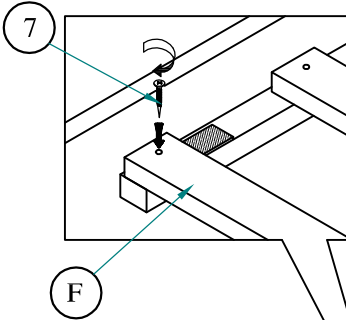

**Step 9 :**

Attach (G) Slat Support Leg & (J) Center Vertical Slat to the bottom of (F) Roll Slat using (4) JCBC 60mm & (5) M6 Spring Washer. Attach the (9) Adjustable leveller and adjust it to level the bed with the floor.

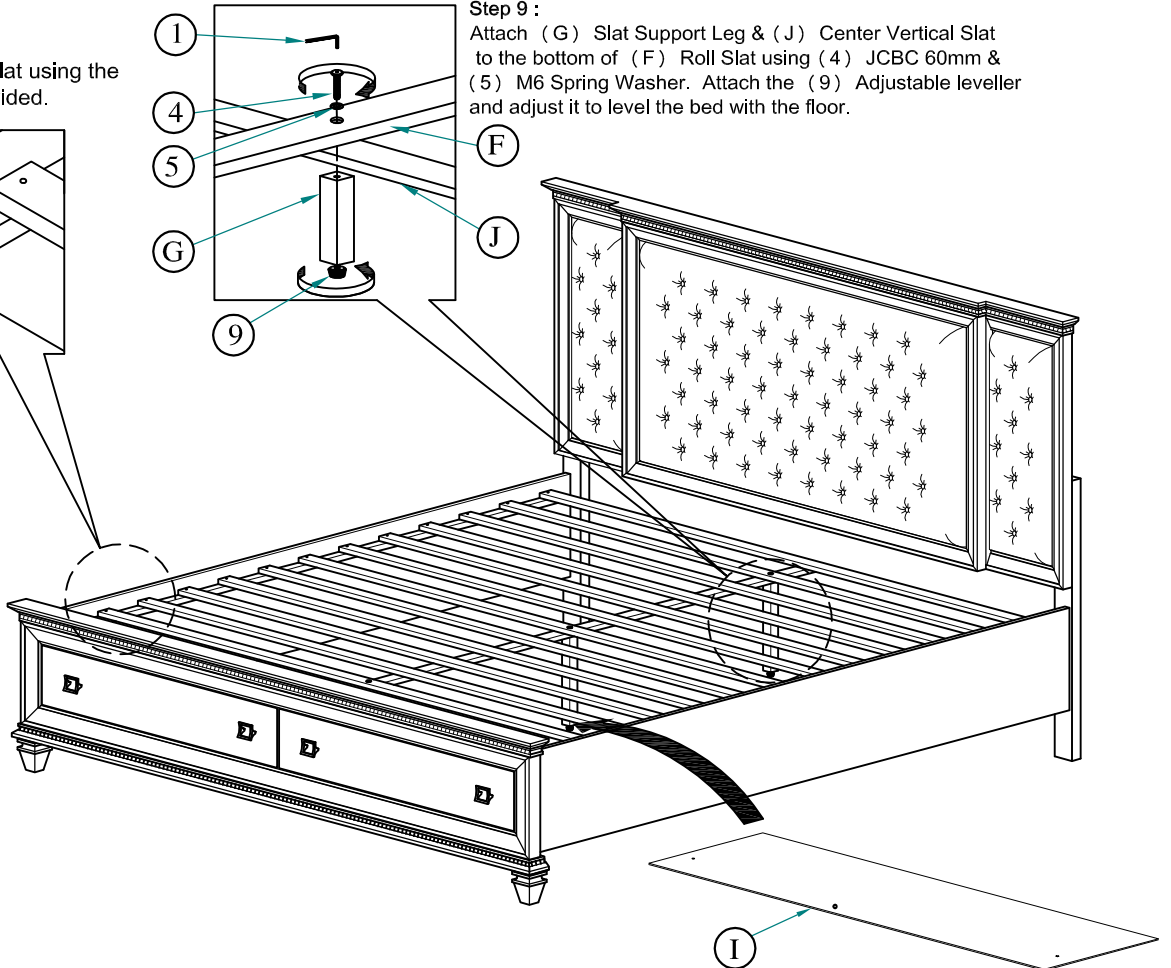

**STEP 10 :**

Attach the (1) Slat Cover Panel to the top of slat close to the footboard and screw using the (8) Screw 16mm provided.

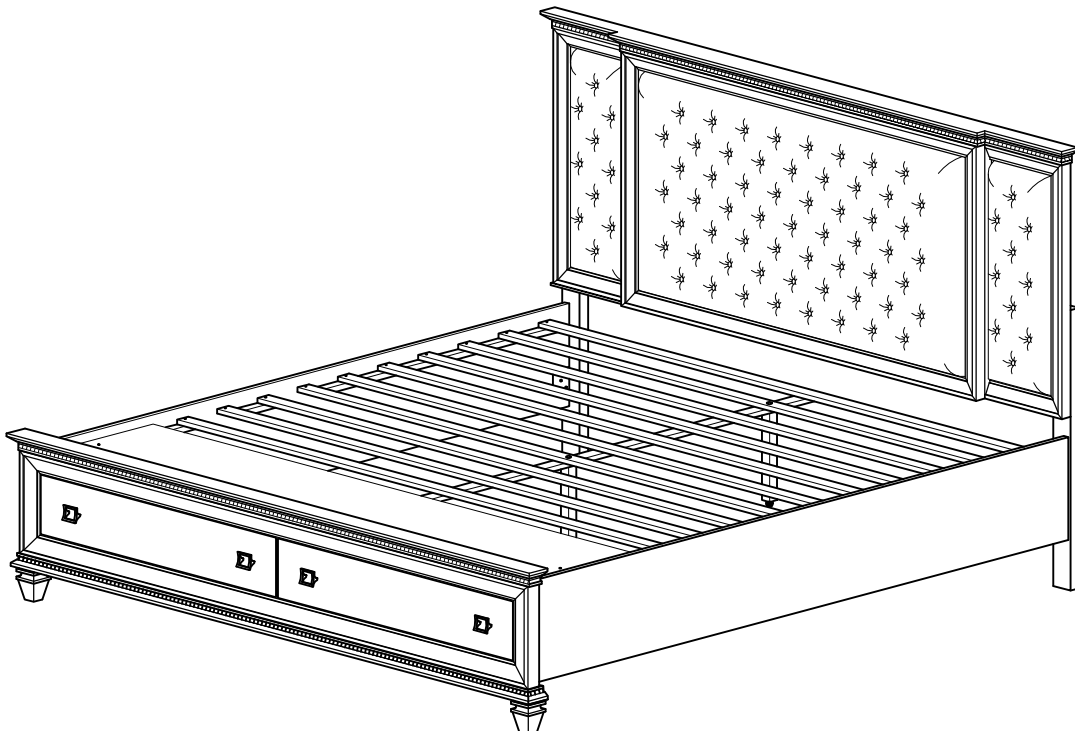
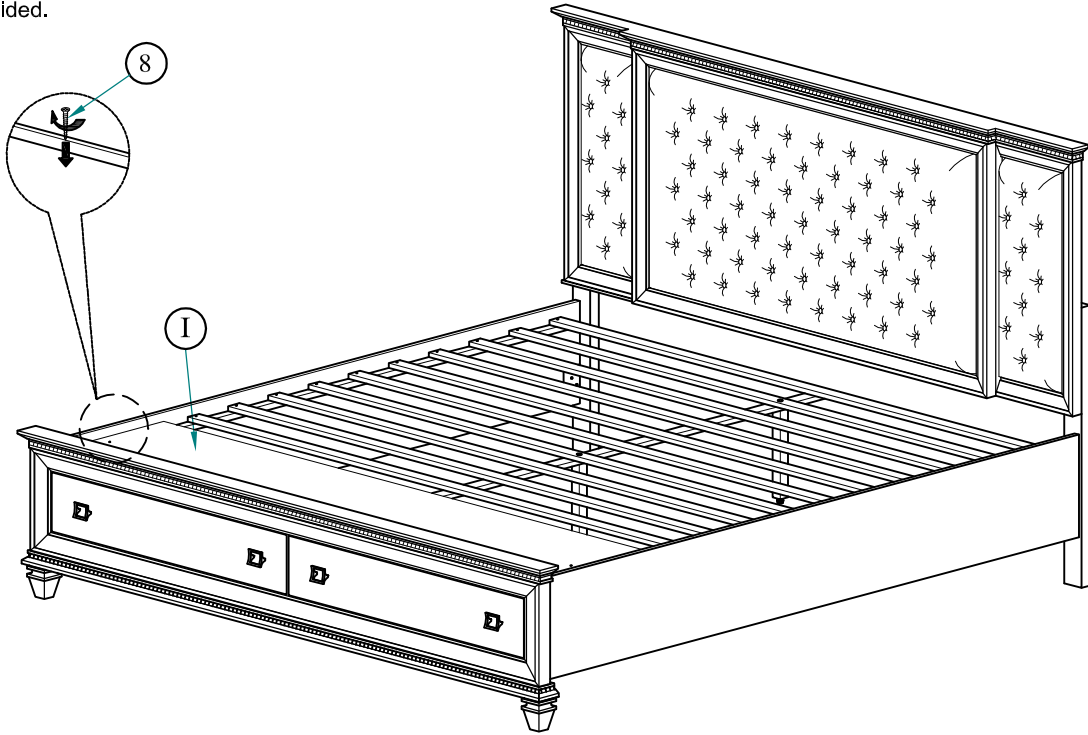

**Assembly completed**