

ASSEMBLY INSTRUCTIONS



Coffee Table

ASSEMBLY INSTRUCTIONS

ASSEMBLY TIPS:

1. Remove hardware from box and sort by size.
2. Please check to see that all hardware and parts are present prior to start of assembly.
3. Please follow attached instructions in the same sequence as numbered to assure fast & easy assembly.



WARNING!

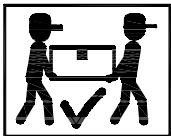

1. Don't attempt to repair or modify parts that are broken or defective. Please contact the store immediately.
2. This product is for home use only and not intended for commercial establishments.







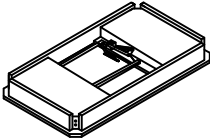

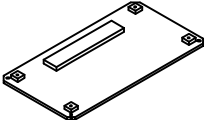

ASSEMBLY TIME

30 MINUTES

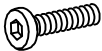
PARTS IDENTIFICATION

A	TOP		1PC		C	LEG		4PCS
B	BOTTOM SHELF		1PC					

HARDWARE IDENTIFICATION

1	ALLEN WRENCH (5MM - BLK)		1PC		5	CASTER WITH LOCK (Ø 40MM -BLK)		2PCS
2	ALLEN BOLT (Ø5/16 x 2" - BLK)		8PCS		6	CASTER (Ø 40MM -BLK)		2PCS
3	LOCK WASHER (Ø5/16"-BLK)		8PCS		7	WRENCH (14MM - BLK)		1PC
4	FLAT WASHER (Ø5/16" x 19MM-BLK)		8PCS		8	SCREW (8 x 1-1/4" - BLK)		4PCS

NOTE:

Phillips head screw driver is required in the assembly process; however, manufacturer does not provide this item.

ASSEMBLY INSTRUCTIONS

STEP 1

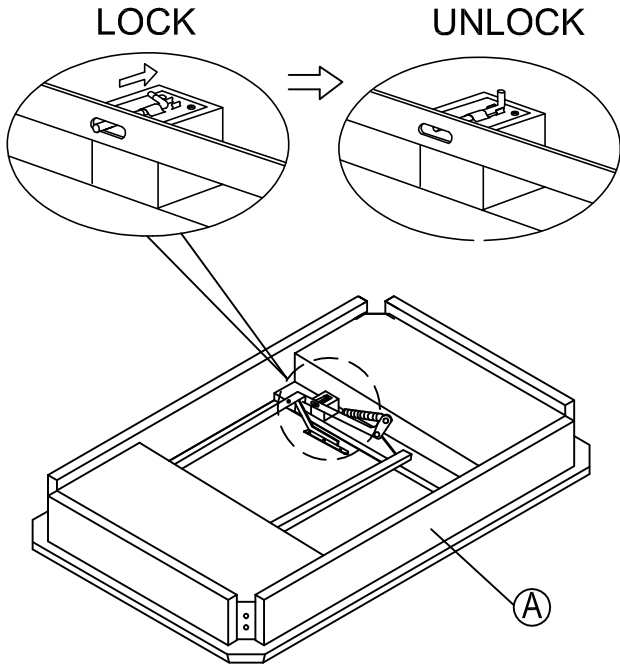

STEP 2

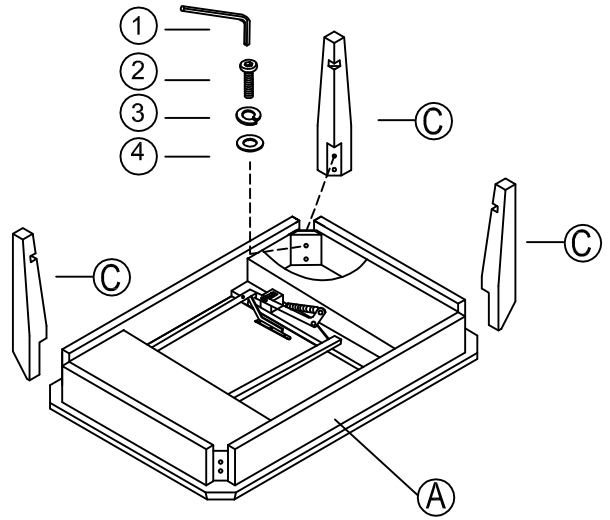

STEP 3

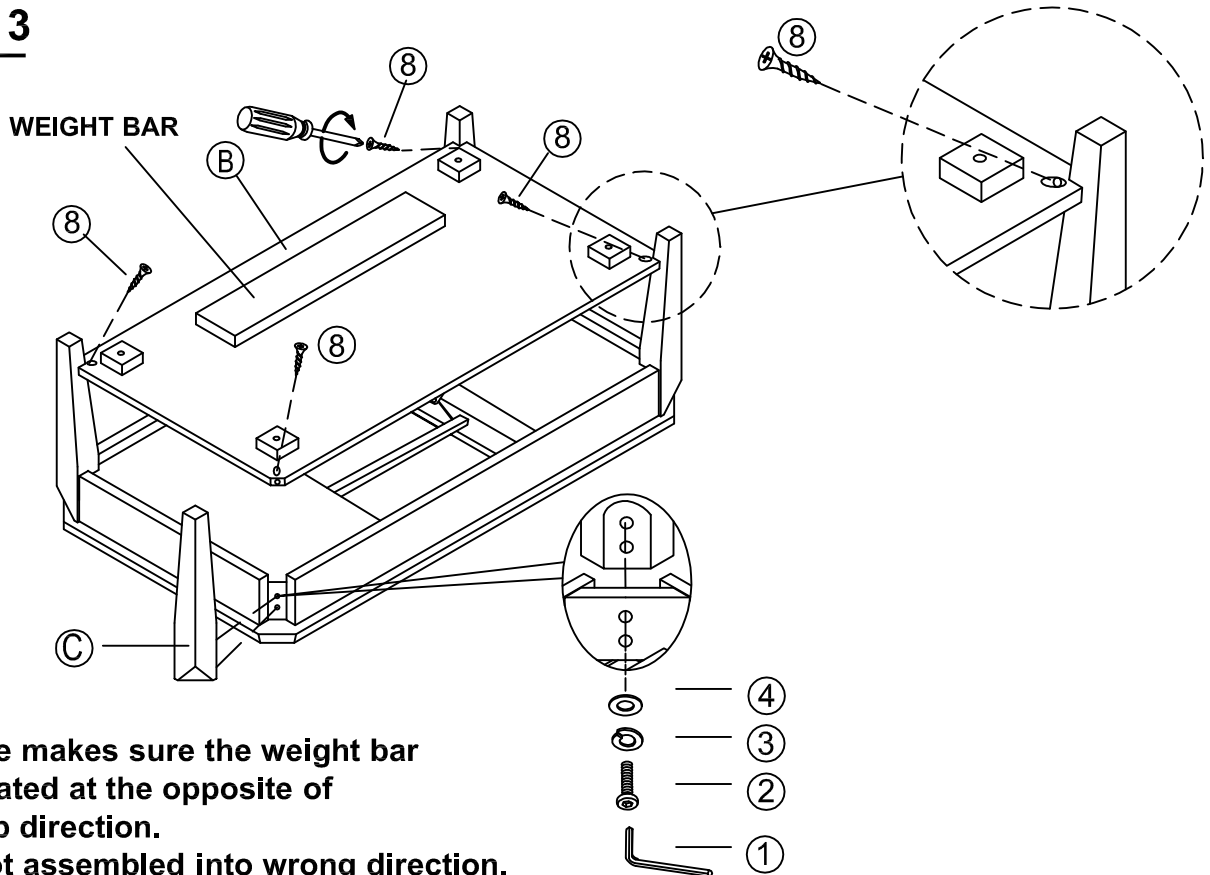

please makes sure the weight bar is located at the opposite of lift top direction.
Do not assembled into wrong direction.

ASSEMBLY INSTRUCTIONS

STEP 4

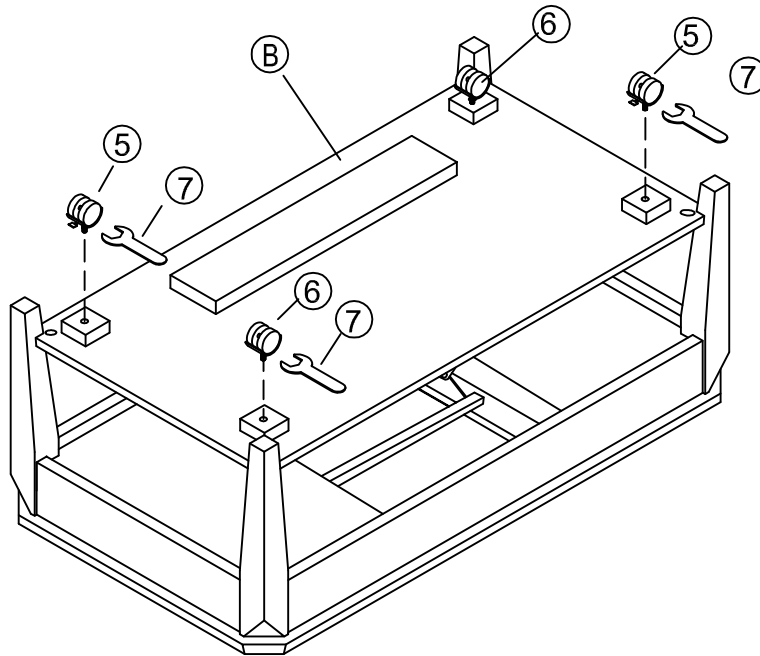

STEP 5 COMPLETE

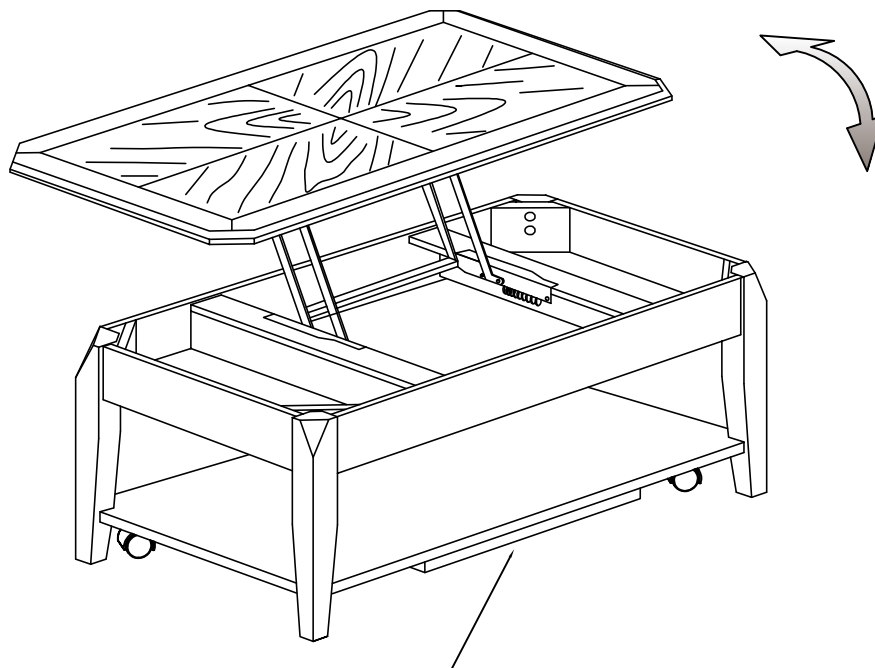

Please make sure the lower panel is assembled on the correct side with weight support to prevent tilting.

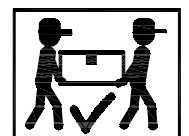

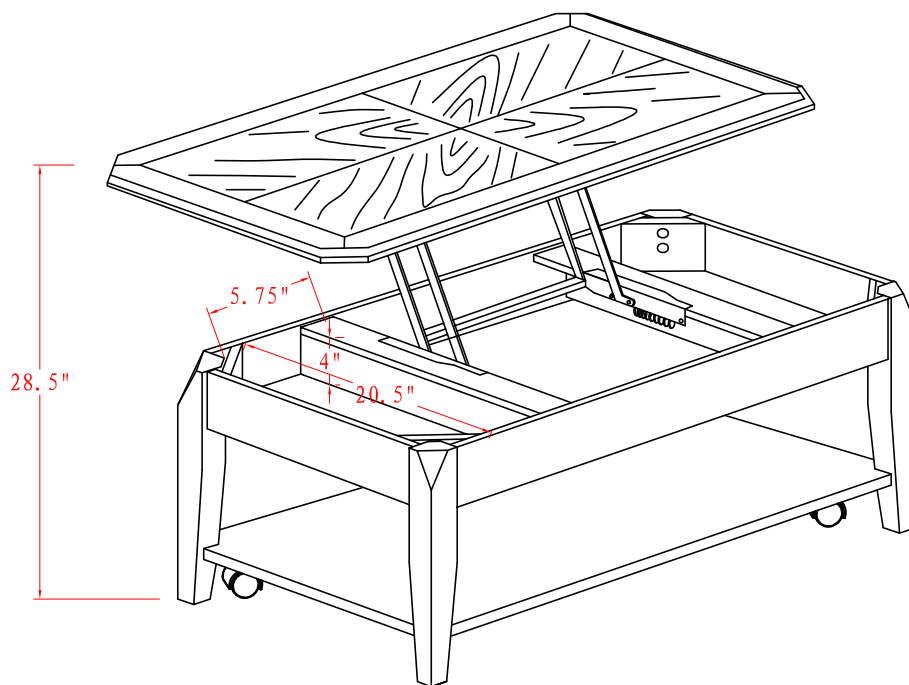
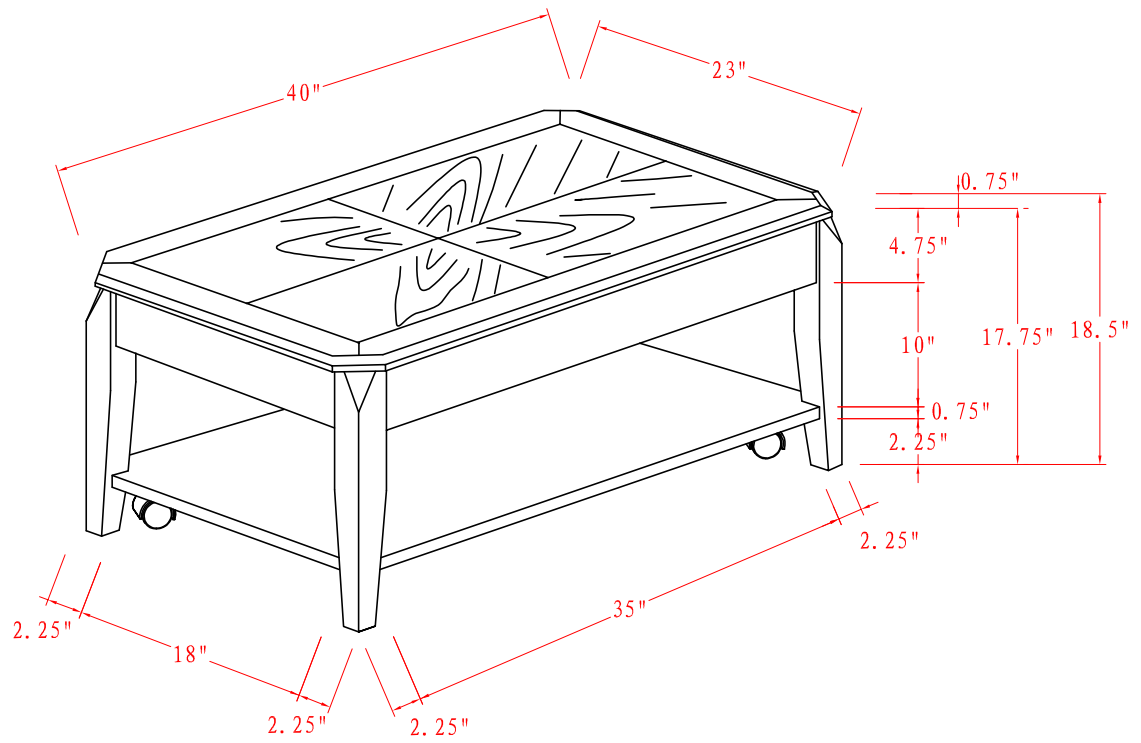

Note : Dimension tolerance $\pm 5\%$