

ASSEMBLY INSTRUCTION

DINING TABLE

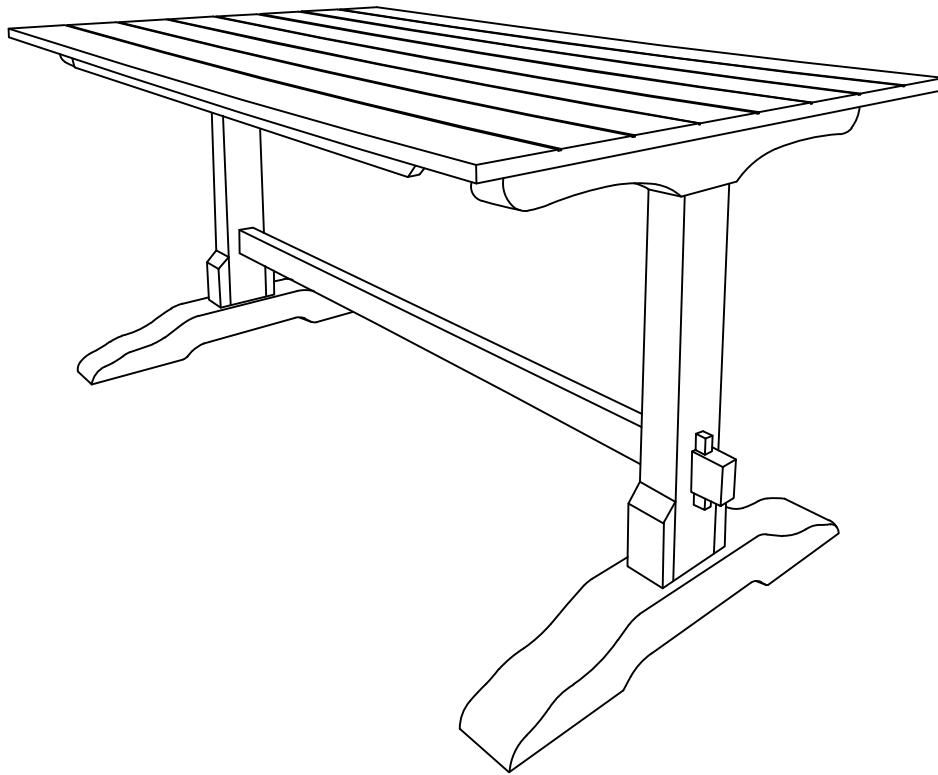

N715P171629

IMPORTANT NOTE:

- PLACE ALL PARTS ON A CLEAN AND SMOOTH SURFACE SUCH AS A RUG OR CARPET TO AVOID THE PARTS FROM BEING SCRATCHED.
- BEFORE YOU BEGIN, KINDLY FOLLOW THE ASSEMBLY INSTRUCTIONS STEP BY STEP.
- DON NOT TIGHTEN ALL SCREWS AND BOLTS UNTIL THE TABLE SET IS FULLY SET-UP.

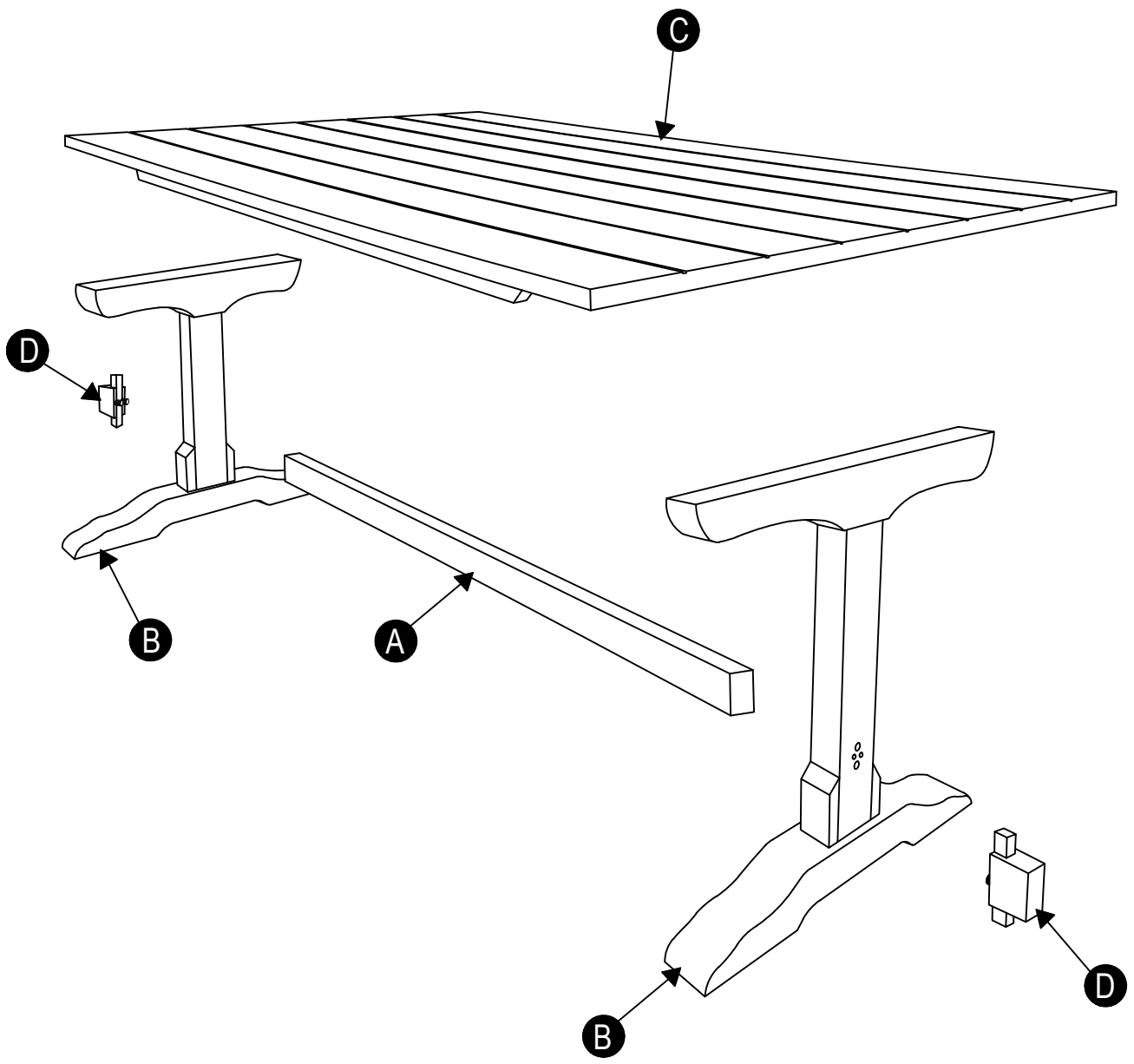

CARTON CONTENT

N715P171629:

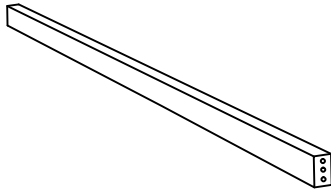

A x 1

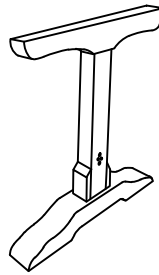



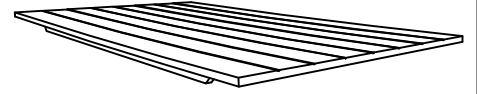



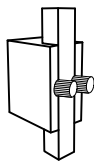

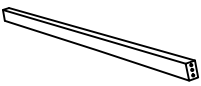

B x 2

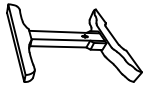

C x 1

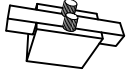

D x 2

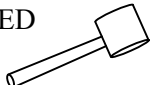
TABLE PART LIST FOR ONE				TABLE HARDWARE LIST FOR ONE			
NO	DESCRIPTION	SKETCH	QTY	NO	DESCRIPTION	SKETCH	QTY
A	CENTER CROSS BAR		1 PC	1	WOOD DOWEL M8 x 30 MM		2 PCS
B	LEG FRAME		2 PCS	2	JCBC SCREW M6 x 60 MM		12 PCS
C	TABLE TOP		1 PCS	3	SPRING WASHER M6		12 PCS
D	LEG SMALL SUPPORT		2 PCS	4	FLAT WASHER M6 x 19 MM		12 PCS
				5	ADJUSTABLE M6 x 23MM		4 PCS
				6	ALLEN KEY M4		1 PC
						NOT INCLUDED	

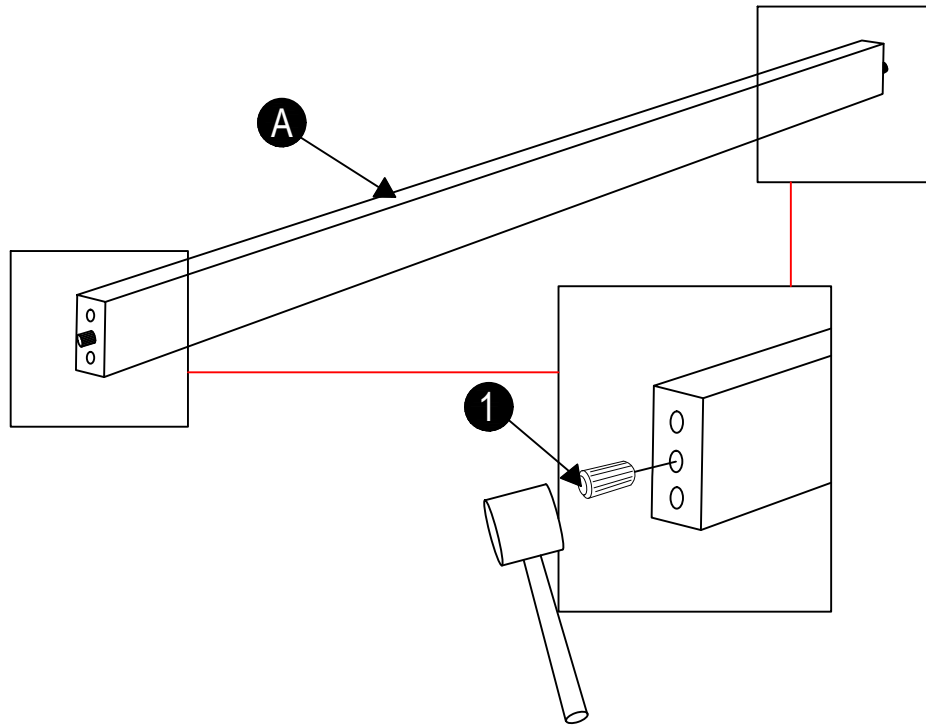

STEP 1



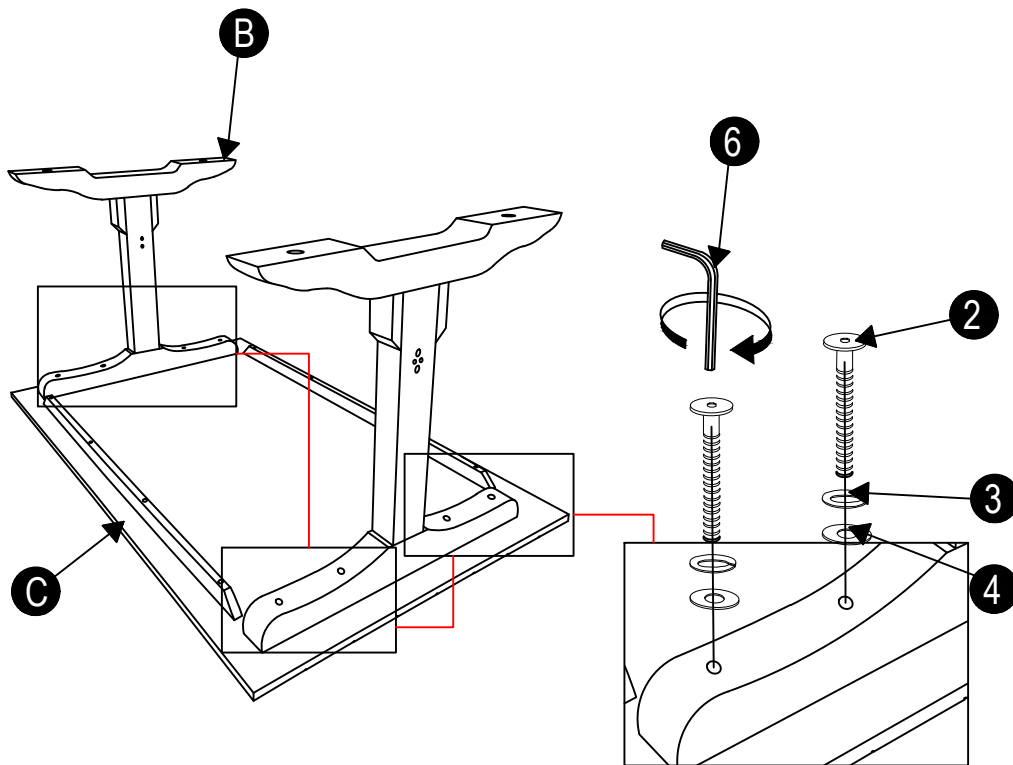

1 X 2pcs

STEP 2





60% 

04-06



2 X 8pcs

3 X 8pcs

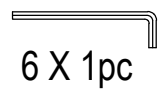
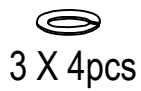
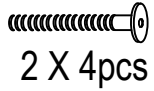
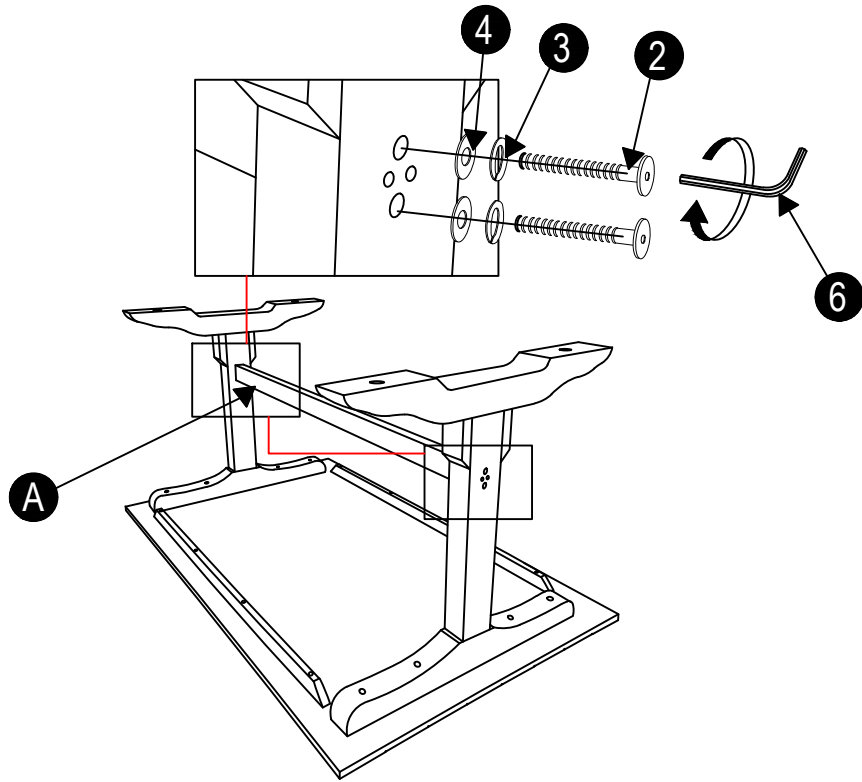

4 X 8pcs

6 X 1pc

STEP 3

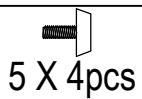
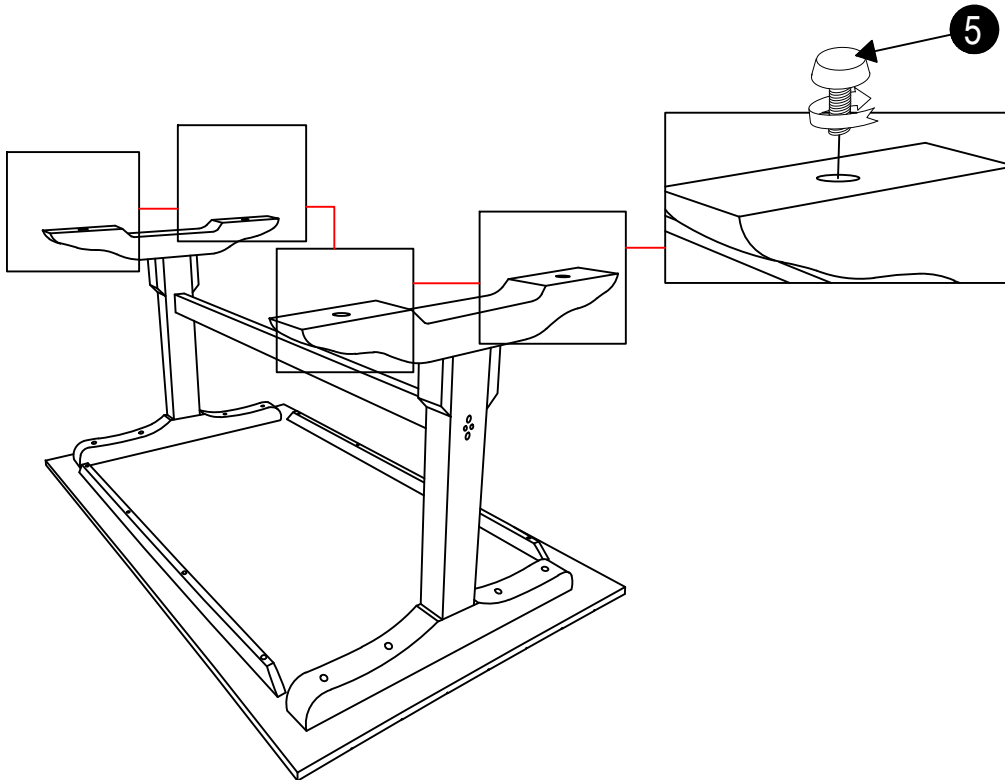

STEP 4



STEP 5

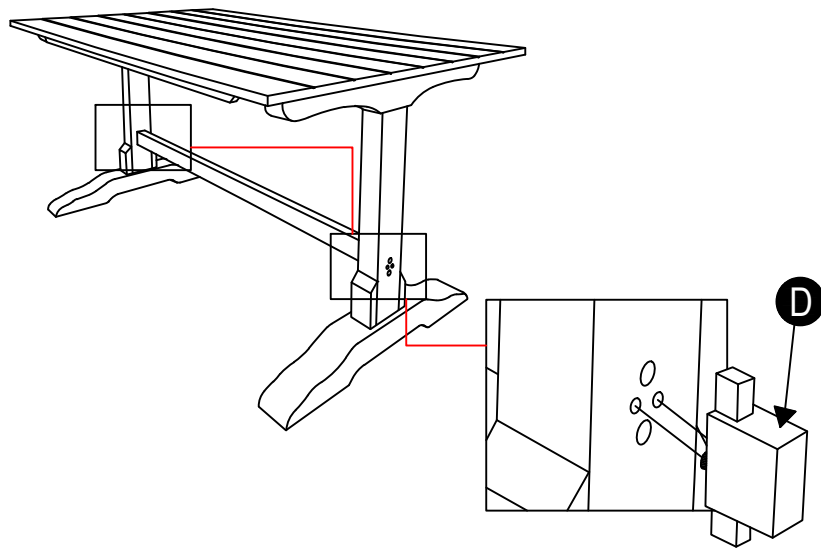

ASSEMBLY COMPLETE !

