

72" x 42" Aluminum Dining Table Slat Top

Assembly Instructions

READ AND SAVE THESE INSTRUCTIONS

Step1: Remove all protective materials and check all component pieces against parts list.

Step2: Place the table top (A) upside down on a soft surface.

Step3: Using the bolts (E) with washer (G) from the table legs (B) to the table top (A) .
And attach other legs same as this leg .

Then using the bolts (E) with washer (G) from the Middle leg (C) to the table top (A) .
See photo 1. **Important :DO NOT TIGHTEN BOLTS AT THIS POINT**

Step4: Align the bolt holes in the leg connector ring (D) with those on the table legs(B)
and Middle Leg (C). From the inside of the leg connector ring (D), loosely attach leg
connector ring (D) to the table legs (B) and Middle Leg (C) using bolts (E&F) through washers (G).
See photo 2.

Important :DO NOT TIGHTEN BOLTS AT THIS POINT

Step5:Tighten all all of bolts and Cover all bolts (E & F) with bolt covers (H)

With the help of another person, carefully turn the table to the upright position.
The table is ready for your enjoyment.

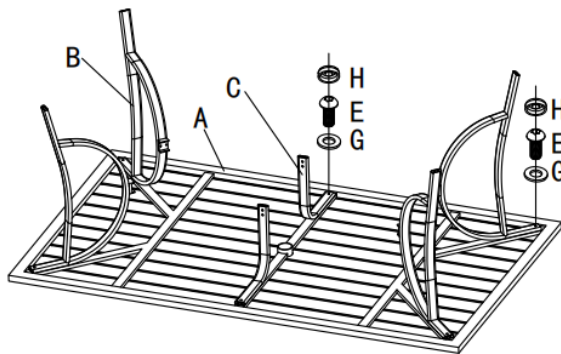

photo 1

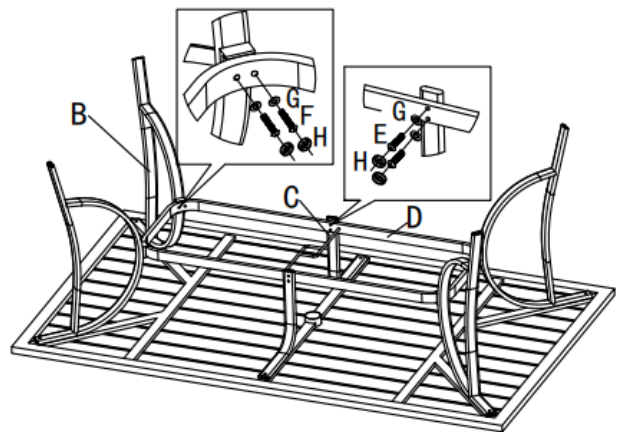

photo 2

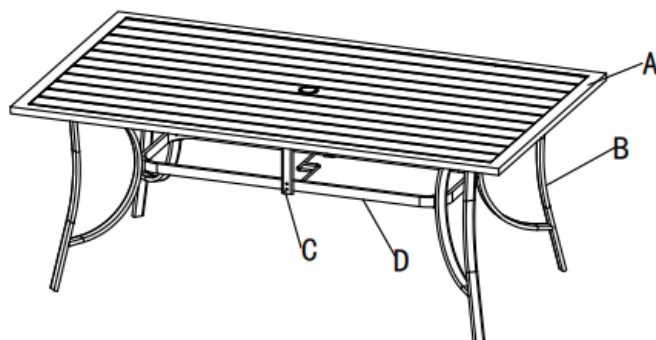



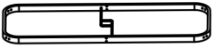







photo 3

PARTS LIST

A	TABLE TOP		1
B	TABLE LEG		4
C	Middle Leg		2
D	Leg Connector Ring		1
E	1/4" X 25mm Bolt		10
F	1/4" X 30mm Bolt		8
G	1/4" Flat washer		18
H	1/4" Bolt cover		18
I	Hex screw driver		1
J	PARASOL CAP		1