

草皮纹抖抖机说明书 2025-12-9

红色线是成品线不印刷 H

内容仔细校对如有问题及时纠正印后不负连带责任

尺寸：145*210MM 装订 70g 双胶纸

145MM

210MM

To the 2-in-1 Shaking machine & Treadmill

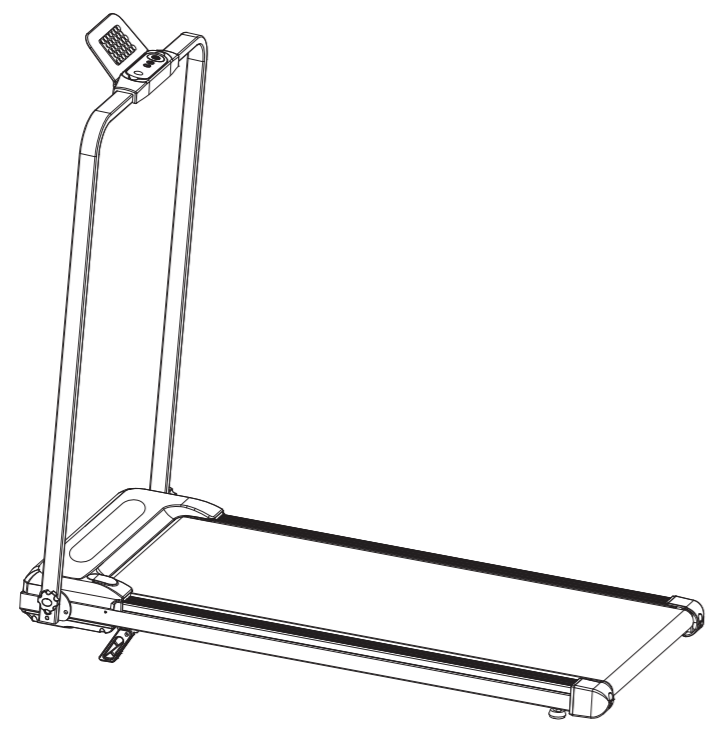

"the entire manual should be carefully read before use/start using" your new treadmill."

Contents:

- Product Instruction Contents.....1
- Safety Precautions and Warnings.....2
- Parameters and Packing List.....5
- Remote Control Instructions.....5
- Exercise Advice and Plan.....7
- Instruction Manual.....8
- Maintenance Guidelines.....8
- Common Malfunctions and Solutions.....11

Product Instructions

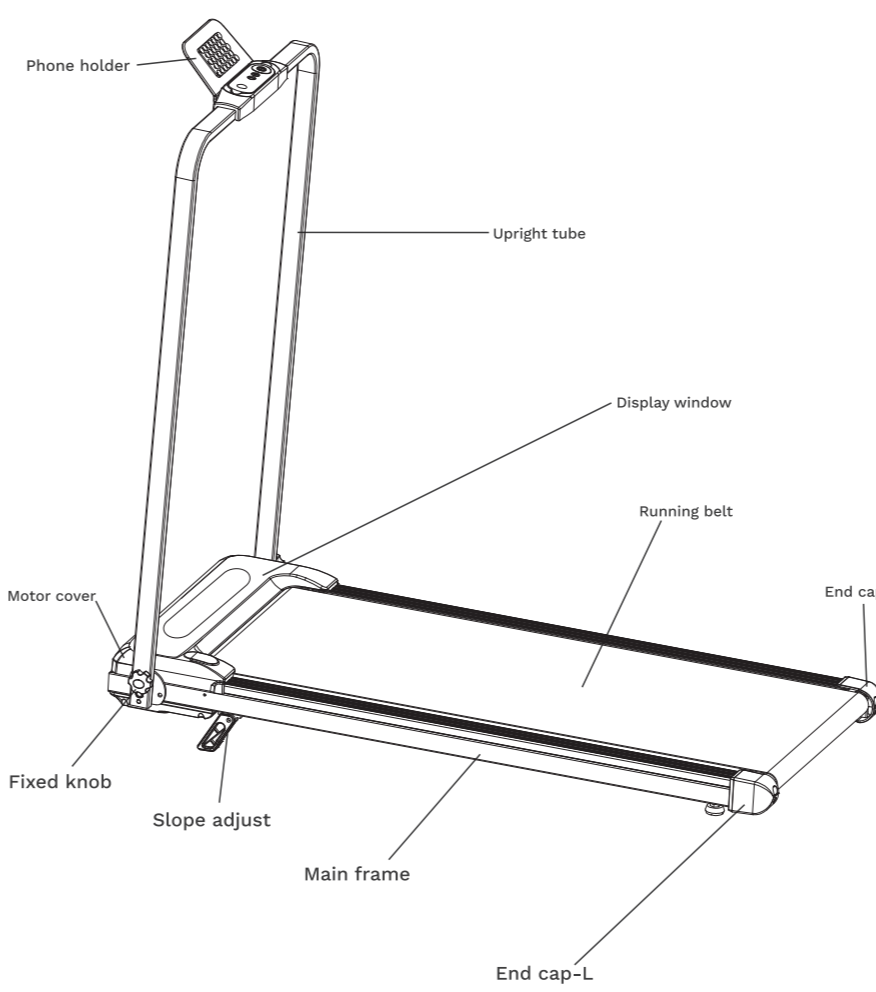

Revised sentence: Safety Precautions and Warnings

- Caution! Please carefully read this manual before using the product and take note of the following issues:
- * This treadmill is intended for indoor use only. Do not expose it to water or other liquids, and do not place any objects on top of it.
 - * Always wear appropriate sports gear and warm up properly before using the treadmill. Never use it barefoot.
 - * The power plug must be grounded, and a dedicated circuit should be used. Do not share a circuit with other electrical equipment.
 - * Keep children away from the treadmill to prevent accidents.
 - * Avoid overloading or prolonged use of the treadmill as this can significantly shorten its lifespan. Regular maintenance is necessary to keep it in good condition.
 - * Reduce dust accumulation and maintain proper humidity levels indoors to prevent electronic devices from being affected by static electricity interference.
 - * Always turn off the treadmill after use, ensure adequate air circulation during operation, stop exercising if you feel uncomfortable, and consult your doctor if necessary. Warning: To avoid accidents or injury, please observe the following precautions:
 - * Check that your sports gear is secure with no loose zippers or hanging strings that could get caught in the machine's moving parts.
 - * Do not put anything near heat sources that could damage power cords or cause fires.
 - * Keep children away from treadmills at all times; never let them play on or around them unsupervised!
 - * Unplug treadmills before moving them; never attempt disassembly unless you are a professional technician trained in maintaining these machines.
 - * The treadmill can only be used in a 20A circuit.
- "The equipment is designed for single use only, and should not be used by multiple individuals simultaneously. If you experience symptoms such as dizziness, chest pain, nausea or shortness of breath during exercise, please discontinue immediately and seek advice from your fitness instructor or physician."

Warning! Must Follow!

Please consult your doctor if you are under therapy or have any of the following issues:

1. If you are suffering from waist pain or hurt your leg, waist or neck before, or have perceived obstacles to your leg, waist, neck and hand (also include disc herniation, spondylolisthesis, cervical protrusion)
2. Deformed arthritis, rheumatism, gout
3. Osteoporosis or bone abnormality
4. Circulatory system disorder (heart disease, vascular disease, high blood pressure)
5. Respiratory system disorder
6. Implant cardiac pacemakers or electronic equipment.
7. Malignant tumor
8. Thrombosis, serious arterial lipoma, acute venous lipoma, and other blood circulation diseases or skin infections.
9. Perceived obstacle caused by diabetes.
10. Wounded on skin
11. Sick or fever (38°C or higher temperature)
12. Spine abnormality or bending
13. Pregnant women or women are in the menstrual period
14. Unhealthy and need rest
15. Obvious condition
16. For physical recovery purposes
17. Other bad feelings besides the situations above, may cause the unexpected condition

*Please stop doing exercise if you feel waist pain, dizziness, palpitations or other abnormal feeling, consult your fitness coach or doctor
*Do not let kids use this product. Kids should be kept away from this product, or it may cause unexpected hurting risk
*Please make sure no other people or pets are around the product when taking, packing or sliding it

Forbidden!

- *Never use if you find the shell is broken and off (inside parts are exposed) or the welding point is broken. Or it may cause unexpected conditions.
- *Never jump on and off the product when you are using it, it may cause falling and injured
- *Never store the product outdoors, near the bathroom, or any place where is damp
- *Never use or store the product under direct sunlight, near the stove, electric blanket or other

heating supply equipment, or it may cause an electric shock or fire accident.

- *Never use the product when you find the power cord or plug is broken or the socket is slack, or it may cause electric shock, short circuit, or fire accident.
- *Never use the product with two or more people at the same time, keep others away when using this product, or it may cause unexpected situations or falling accidents.
- *Never use the product if the user can not express self-consciousness or can not operate the product by himself/herself. Or it may cause unexpected situations.
- *Keep the product away from water or other liquid, especially the main base. Or it may cause electric shock or fire accidents.
- *Never do intense exercise if you don't exercise usually. Do not use it after meals, fatigue, or other uncomfortable state, or it may be harmful to your health.
- *This product is only for home use, never use it at school, stadium or other public place, or it may cause unexpected situations.
- *Never use the product if you are eating or doing other behaviors, also never use it after drinking, or it may cause an accident or injury.
- *Never take your watch, bracelet, mobile phone and other valuable objects with you to avoid damage, also take off your keys and knife to avoid hurting yourself.
- *Please check the power cord whether there is a needle, garbage or other wet things before using it to avoid electric shock, short circuit or fire accident.
- *Never touch the plug with a wet hand to avoid electric shock.
- *Please turn the power switch to the off position and unplug the plug if do not use it for a period to avoid electricity shock or fire accidents caused by insulation deterioration.
- *Pull out the power plug!
- When not in use, pull out the power plug from the socket.
- Because dust and moisture will degrade the insulation, which will lead to leakage fire.

Grounding explanation !

- * This product must be grounded, it can greatly reduce the risk of electricity shock when the product is in malfunction.
- * The plug of this product is grounding standard, please use a local legal grounding power source to connect the product.

Dangerous !

- * It may cause electricity shock if the product is not grounding properly, please ask a professional electrician to check if you are not sure whether the grounding is correct. Never modify the plug if it can not fit your power source, please ask a professional electrician to install a proper power source.
- *Never use a transfer plug, this product must connect to a power source with a grounding function.

Parameter and Packing List

Parameters		Packing List	
NO.	Parameter Name	NO.	Name
1	Input Voltage	1	Main body
2	peak power	2	Remote control
3	Speed Range	3	Allen Wrench
4	Running Belt Area	4	Manual
5	Maximum Load		
6	Expanded Dimension		
7	N.W.G.W		
8	Functions		

Assembly Instructions

- Installation steps of standpipe :
1. place the product on the floor after taking out the product from the packing box.

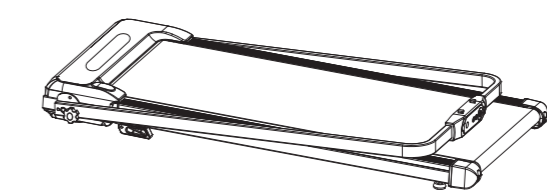

2. Raise the standpipe until it stands still Tighten the screw to fix the handrail. (tighten the screw in a clockwise direction, Loosen the screws in an anticlockwise direction when dismantlement is needed)

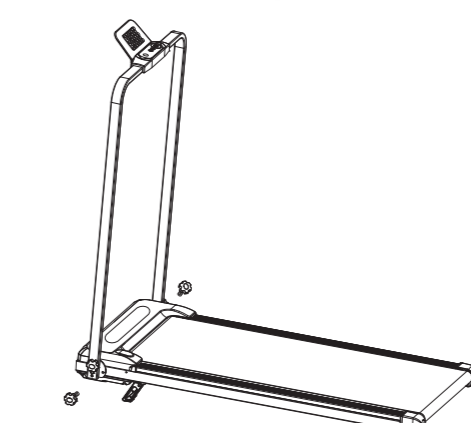

3. Plug in the power supply, turn it on, and use the remote control to start up and adjust the speed.
4. Slope adjust
5. Shaking Machine

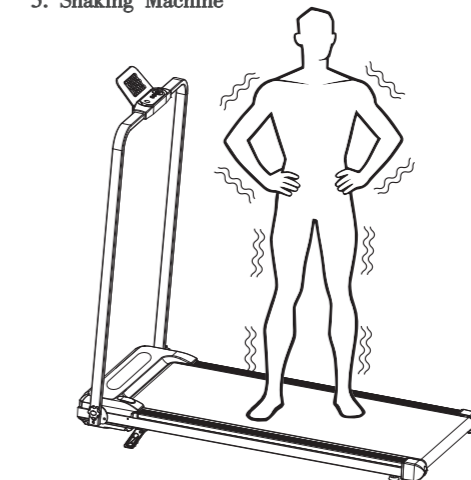

Exercise advice and plan

- *Warm up do warm-up exercises for 5-10 minutes before using this product
- *Breath do not hold your breath when you are using this product, try to breathe by the nose and coordinate with your movement, you should stop if your breath is too hoarse.
- *Exercise frequency muscle should rest for 48 hours after exercise
- *Intensity it depends on different individuals, please increase the intensity gradually, the fatigue can be cured under the situation.
- *Diet To protect the digestive system, please use this product 1 hour after a meal, also do not take any food half an hour after exercise, Try to not drink not too much water when exercising to reduce visceral burden.
- *Stretching Exercises No matter what speed you run, stretching exercise is necessary firstly, it can improve muscle activity and reduce the risk of sports injuries. So you can follow the guidance below after warming up, 3 times for each pose, and do it again after exercise.

1. Stretch down bend down relax your shoulder and back then try to touch your feet, 3 times (Picture 1)
2. Stretch legs sit on a mat, and stretch one leg and keep the other to stay balanced then try to touch your toes on the straight leg, and try the Pose for 10-15 seconds then repeat to the other leg, 3 times (picture 2)
3. Stand and put your hands on the wall or table, then push your body down and stay 10-15 seconds, 3 times for each leg (picture 3)
4. Ankle joint stretch Stand and hold something to keep balance, then pull one ankle to your buttocks until you feel tense in your leg muscle, stay 10-15 seconds, 3 times for each leg (picture 4)
5. Thigh stretch sit and keep feet against, then pull feet to the groin, stay 10-15 seconds, and do it 3 times (picture 5)



Instruction manual

- *Brief introduction It is an easy-operating machine, it does not require complicated operation instructions: Treadmill related : speed Sports related : distance, calorie time
- *LED digital display
- 1. TIME
- 2. DISTANCE
- 3. SPEED
- 4. CALORIE

Parameter

5. Voltage : 110V/50-60HZ
6. Minimum speed : 0.5MI
7. Maximum speed : 5MI

Maintenance

- LUBRICATING YOUR TREADMILL
1. After using the running belt for some time, it is necessary to lubricate your treadmill.

The recommended lubrication time is: Lubricating once every 5 months for the use of fewer than 3 hours per week. Lubricating once every 2 months for the use of 4-7 hours per week. Lubricating once every month for the use of more than 7 hours per week.

WARNING: Always unplug the treadmill from the electrical outlet before cleaning, and lubricating the unit. Check whether lubrication is required Grep the running belt, and touch the back center areas of the running belt as much as possible, if there is oil on the belt (or it feels a little wet), means no lubrication is needed. If you feel that the running board is dry and there is no oil on your hand, you need to add oil to lubricate the treadmill.

HOW TO LUBRICATE: Raise the Running Belt up on one side and apply lubricant to the Running Board. Use a rag to thoroughly wipe the lubricant over the Running Board. Repeat this process for the other side.

2. The moving parts should turn freely and quietly. The abnormality of moving parts will affect the safety of the equipment. Inspect and tighten all bolts regularly.
3. To better maintain the treadmill and prolong its lifespan, it is suggested that maintenance be done on a regular basis.
4. DO NOT LOOSEN OR MAKE ANY ADJUSTMENTS TO THE RUNNING BELT WHILE APPLYING LUBRICANT. A loose Running Belt will result in the runner sliding off during use, while too tight of a Running Belt will negatively affect the motor performance and also create more friction between the roller and the Running Belt.

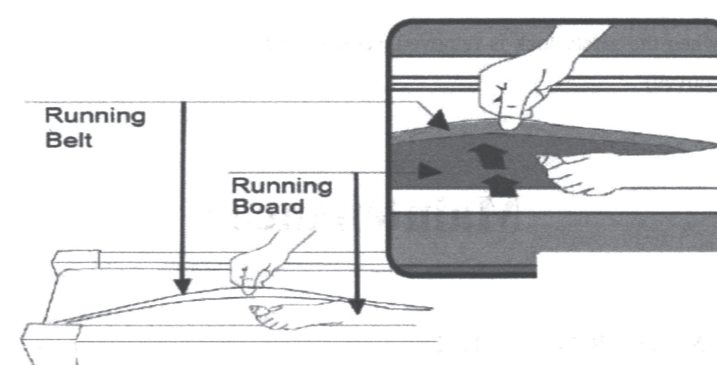

ELASTIC TENDENCY ADJUSTMENT OF RUNNING BELT

Every treadmill would set the elastic tendency before it leaves the factory and after assembly, but it will become looser after use for a period. Just like it will be stuck or slide sometimes, you can turn the adjusting bolt in a clockwise direction, and semi-circle a time (left and right at the same time) to adjust the running belt. Don't make it too loose or too tight, or the running belt will slide or make the motor overloaded .

RUNNING BELT DEVIATING

There are some factors cause this situation :
A: the treadmill is not placed on the flat floor
B: User does not step on the center of the running belt
Just setting the treadmill flat and running idly will solve the issue:
If the deviating still exists, you can adjust it with a 6mm Allen wrench in a quarter turn. Deviating is out of warranty. Users can maintain it by the instructions below: Please fix it as soon as you find the problem or it will break the running belt.



If the belt is off-center to the LEFT, turn the left adjusting bolt 1/2 turn clockwise or the right adjusting bolt 1/2 turn counterclockwise which moves the running belt to the right.

If the belt is off-center to the RIGHT, turn the left adjusting bolt 1/2 turn counterclockwise or the right adjusting bolt 1/2 turn clockwise which moves the running belt to the left.

- A: Turn the screw in a clockwise direction with an Allen wrench
- B: Adjust the intensity, when the running belt will not slide during load is ok (clean the debris between belt ditch and belt wheels)

Treadmill brushless motor control troubleshooting method

Serial number	fault phenomenon	Possible reasons	Processing method	alarm value
1	Treadmill without display	1. Not plugged into power or power 2. Whether power switch is not turned on 3. Whether power switch is not turned on 4. Whether power switch is not turned on	1. Plug the power cord into the power outlet and check if the switch has electricity 2. Turn the power switch on the ON position 3. Press the remote control power button 4. Check the power switch	
2	Treadmill has display, but no backlight or screen does not display	1. Whether power switch is not turned on 2. Whether power switch is not turned on 3. Whether power switch is not turned on	1. Plug the power cord into the power outlet and check if the switch has electricity 2. Turn the power switch on the ON position 3. Press the remote control power button 4. Check the power switch	
3	The electronic display is incomplete or missing strokes	1. Whether power switch is not turned on 2. Whether power switch is not turned on 3. Whether power switch is not turned on	1. Plug the power cord into the power outlet and check if the switch has electricity 2. Turn the power switch on the ON position 3. Press the remote control power button 4. Check the power switch	
4	Electronic display shows -- or --	1. Whether power switch is not turned on 2. Whether power switch is not turned on 3. Whether power switch is not turned on	1. Plug the power cord into the power outlet and check if the switch has electricity 2. Turn the power switch on the ON position 3. Press the remote control power button 4. Check the power switch	
5	Electronic report E10 communication fault	1. Whether power switch is not turned on 2. Whether power switch is not turned on 3. Whether power switch is not turned on	1. Plug the power cord into the power outlet and check if the switch has electricity 2. Turn the power switch on the ON position 3. Press the remote control power button 4. Check the power switch	
6	Electronic report E02 overcurrent protection fault	1. Whether power switch is not turned on 2. Whether power switch is not turned on 3. Whether power switch is not turned on	1. Plug the power cord into the power outlet and check if the switch has electricity 2. Turn the power switch on the ON position 3. Press the remote control power button 4. Check the power switch	
7	Electronic report E03 overcurrent protection or fan or three phase wires of the motor are not connected	1. Whether power switch is not turned on 2. Whether power switch is not turned on 3. Whether power switch is not turned on	1. Plug the power cord into the power outlet and check if the switch has electricity 2. Turn the power switch on the ON position 3. Press the remote control power button 4. Check the power switch	

LED DISPLAY PANEL

Walking mode

vibration mode

Light vibration mode: 1MI high frequency vibration

Strong vibration mode: 2MI high frequency vibration

Light high frequency vibration: 3MI high frequency vibration

Strong high frequency vibration: 4MI high frequency vibration

Window and key description:

1. Remote control operation instructions (one beep for each button press)
 - A. Start key for running
 - B. Start/Continue key for running
 - C. Stop key for running
 - D. Forwarding start/stop key
 - E. Fast forwarding start/stop key
 - F. Fast forwarding stop/stop key
 - G. Stop key for running
 - H. Stop key for running
 - I. Stop key for running
 - J. Stop key for running
 - K. Stop key for running
 - L. Stop key for running
 - M. Stop key for running
 - N. Stop key for running
 - O. Stop key for running
 - P. Stop key for running
 - Q. Stop key for running
 - R. Stop key for running
 - S. Stop key for running
 - T. Stop key for running
 - U. Stop key for running
 - V. Stop key for running
 - W. Stop key for running
 - X. Stop key for running
 - Y. Stop key for running
 - Z. Stop key for running
 - AA. Stop key for running
 - AB. Stop key for running
 - AC. Stop key for running
 - AD. Stop key for running
 - AE. Stop key for running
 - AF. Stop key for running
 - AG. Stop key for running
 - AH. Stop key for running
 - AI. Stop key for running
 - AJ. Stop key for running
 - AK. Stop key for running
 - AL. Stop key for running
 - AM. Stop key for running
 - AN. Stop key for running
 - AO. Stop key for running
 - AP. Stop key for running
 - AQ. Stop key for running
 - AR. Stop key for running
 - AS. Stop key for running
 - AT. Stop key for running
 - AU. Stop key for running
 - AV. Stop key for running
 - AW. Stop key for running
 - AX. Stop key for running
 - AY. Stop key for running
 - AZ. Stop key for running
 - BA. Stop key for running
 - BB. Stop key for running
 - BC. Stop key for running
 - BD. Stop key for running
 - BE. Stop key for running
 - BF. Stop key for running
 - BG. Stop key for running
 - BH. Stop key for running
 - BI. Stop key for running
 - BJ. Stop key for running
 - BK. Stop key for running
 - BL. Stop key for running
 - BM. Stop key for running
 - BN. Stop key for running
 - BO. Stop key for running
 - BP. Stop key for running
 - BQ. Stop key for running
 - BR. Stop key for running
 - BS. Stop key for running
 - BT. Stop key for running
 - BU. Stop key for running
 - BV. Stop key for running
 - BW. Stop key for running
 - BX. Stop key for running
 - BY. Stop key for running
 - BZ. Stop key for running
 - CA. Stop key for running
 - CB. Stop key for running
 - CC. Stop key for running
 - CD. Stop key for running
 - CE. Stop key for running
 - CF. Stop key for running
 - CG. Stop key for running
 - CH. Stop key for running
 - CI. Stop key for running
 - CJ. Stop key for running
 - CK. Stop key for running
 - CL. Stop key for running
 - CM. Stop key for running
 - CN. Stop key for running
 - CO. Stop key for running
 - CP. Stop key for running
 - CQ. Stop key for running
 - CR. Stop key for running
 - CS. Stop key for running
 - CT. Stop key for running
 - CU. Stop key for running
 - CV. Stop key for running
 - CW. Stop key for running
 - CX. Stop key for running
 - CY. Stop key for running
 - CZ. Stop key for running
 - DA. Stop key for running
 - DB. Stop key for running
 - DC. Stop key for running
 - DD. Stop key for running
 - DE. Stop key for running
 - DF. Stop key for running
 - DG. Stop key for running
 - DH. Stop key for running
 - DI. Stop key for running
 - DJ. Stop key for running
 - DK. Stop key for running
 - DL. Stop key for running
 - DM. Stop key for running
 - DN. Stop key for running
 - DO. Stop key for running
 - DP. Stop key for running
 - DQ. Stop key for running
 - DR. Stop key for running
 - DS. Stop key for running
 - DT. Stop key for running
 - DU. Stop key for running
 - DV. Stop key for running
 - DW. Stop key for running
 - DX. Stop key for running
 - DY. Stop key for running
 - DZ. Stop key for running
 - EA. Stop key for running
 - EB. Stop key for running
 - EC. Stop key for running
 - ED. Stop key for running
 - EE. Stop key for running
 - EF. Stop key for running
 - EG. Stop key for running
 - EH. Stop key for running
 - EI. Stop key for running
 - EJ. Stop key for running
 - EK. Stop key for running
 - EL. Stop key for running
 - EM. Stop key for running
 - EN. Stop key for running
 - EO. Stop key for running
 - EP. Stop key for running
 - EQ. Stop key for running
 - ER. Stop key for running
 - ES. Stop key for running
 - ET. Stop key for running
 - EU. Stop key for running
 - EV. Stop key for running
 - EW. Stop key for running
 - EX. Stop key for running
 - EY. Stop key for running
 - EZ. Stop key for running
 - FA. Stop key for running
 - FB. Stop key for running
 - FC. Stop key for running
 - FD. Stop key for running
 - FE. Stop key for running
 - FF. Stop key for running
 - FG. Stop key for running
 - FH. Stop key for running
 - FI. Stop key for running
 - FJ. Stop key for running
 - FK. Stop key for running
 - FL. Stop key for running
 - FM. Stop key for running
 - FN. Stop key for running
 - FO. Stop key for running
 - FP. Stop key for running
 - FQ. Stop key for running
 - FR. Stop key for running
 - FS. Stop key for running
 - FT. Stop key for running
 - FU. Stop key for running
 - FV. Stop key for running
 - FW. Stop key for running
 - FX. Stop key for running
 - FY. Stop key for running
 - FZ. Stop key for running
 - GA. Stop key for running
 - GB. Stop key for running
 - GC. Stop key for running
 - GD. Stop key for running
 - GE. Stop key for running
 - GF. Stop key for running
 - GG. Stop key for running
 - GH. Stop key for running
 - GI. Stop key for running
 - GJ. Stop key for running
 - GK. Stop key for running
 - GL. Stop key for running
 - GM. Stop key for running
 - GN. Stop key for running
 - GO. Stop key for running
 - GP. Stop key for running
 - GQ. Stop key for running
 - GR. Stop key for running
 - GS. Stop key for running
 - GT. Stop key for running
 - GU. Stop key for running
 - GV. Stop key for running
 - GW. Stop key for running
 - GX. Stop key for running
 - GY. Stop key for running
 - GA. Stop key for running
 - GB. Stop key for running
 - GC. Stop key for running
 - GD. Stop key for running
 - GE. Stop key for running
 - GF. Stop key for running
 - GG. Stop key for running
 - GH. Stop key for running
 - GI. Stop key for running
 - GJ. Stop key for running
 - GK. Stop key for running
 - GL. Stop key for running
 - GM. Stop key for running
 - GN. Stop key for running
 - GO. Stop key for running
 - GP. Stop key for running
 - GQ. Stop key for running
 - GR. Stop key for running
 - GS. Stop key for running
 - GT. Stop key for running
 - GU. Stop key for running
 - GV. Stop key for running
 - GW. Stop key for running
 - GX. Stop key for running
 - GY. Stop key for running
 - GA. Stop key for running
 - GB. Stop key for running
 - GC. Stop key for running
 - GD. Stop key for running
 - GE. Stop key for running
 - GF. Stop key for running
 - GG. Stop key for running
 - GH. Stop key for running
 - GI. Stop key for running
 - GJ. Stop key for running
 - GK. Stop key for running
 - GL. Stop key for running
 - GM. Stop key for running
 - GN. Stop key for running
 - GO. Stop key for running
 - GP. Stop key for running
 - GQ. Stop key for running
 - GR. Stop key for running
 - GS. Stop key for running
 - GT. Stop key for running
 - GU. Stop key for running
 - GV. Stop key for running
 - GW. Stop key for running
 - GX. Stop key for running
 - GY. Stop key for running
 - GA. Stop key for running
 - GB. Stop key for running
 - GC. Stop key for running
 - GD. Stop key for running
 - GE. Stop key for running
 - GF. Stop key for running
 - GG. Stop key for running
 - GH. Stop key for running
 - GI. Stop key for running
 - GJ. Stop key for running
 - GK. Stop key for running
 - GL. Stop key for running
 - GM. Stop key for running
 - GN. Stop key for running
 - GO. Stop key for running
 - GP. Stop key for running
 - GQ. Stop key for running
 - GR. Stop key for running
 - GS. Stop key for running
 - GT. Stop key for running
 - GU. Stop key for running
 - GV. Stop key for running
 - GW. Stop key for running
 - GX. Stop key for running
 - GY. Stop key for running
 - GA. Stop key for running
 - GB. Stop key for running
 - GC. Stop key for running
 - GD. Stop key for running
 - GE. Stop key for running
 - GF. Stop key for running
 - GG. Stop key for running
 - GH. Stop key for running
 - GI. Stop key for running
 - GJ. Stop key for running
 - GK. Stop key for running
 - GL. Stop key for running
 - GM. Stop key for running
 - GN. Stop key for running
 - GO. Stop key for running
 - GP. Stop key for running
 - GQ. Stop key for running
 - GR. Stop key for running
 - GS. Stop key for running
 - GT. Stop key for running
 - GU. Stop key for running
 - GV. Stop key for running
 - GW. Stop key for running
 - GX. Stop key for running
 - GY. Stop key for running
 - GA. Stop key for running
 - GB. Stop key for running
 - GC. Stop key for running
 - GD. Stop key for running
 - GE. Stop key for running
 - GF. Stop key for running
 - GG. Stop key for running
 - GH. Stop key for running
 - GI. Stop key for running
 - GJ. Stop key for running
 - GK. Stop key for running
 - GL. Stop key for running
 - GM. Stop key for running
 - GN. Stop key for running
 - GO. Stop key for running
 - GP. Stop key for running
 - GQ. Stop key for running
 - GR. Stop key for running
 - GS. Stop key for running
 - GT. Stop key for running
 - GU. Stop key for running
 - GV. Stop key for running
 - GW. Stop key for running
 - GX. Stop key for running
 - GY. Stop key for running
 - GA. Stop key for running
 - GB. Stop key for running
 - GC. Stop key for running
 - GD. Stop key for running
 - GE. Stop key for running
 - GF. Stop key for running
 - GG. Stop key for running
 - GH. Stop key for running
 - GI. Stop key for running
 - GJ. Stop key for running
 - GK. Stop key for running
 - GL. Stop key for running
 - GM. Stop key for running
 - GN. Stop key for running
 - GO. Stop key for running
 - GP. Stop key for running
 - GQ. Stop key for running
 - GR. Stop key for running
 - GS. Stop key for running
 - GT. Stop key for running
 - GU. Stop key for running
 - GV. Stop key for running
 - GW. Stop key for running
 - GX. Stop key for running
 - GY. Stop key for running
 - GA. Stop key for running
 - GB. Stop key for running
 - GC. Stop key for running
 - GD. Stop key for running
 - GE. Stop key for running
 - GF. Stop key for running
 - GG. Stop key for running
 - GH. Stop key for running
 - GI. Stop key for running
 - GJ. Stop key for running
 - GK. Stop key for running
 - GL. Stop key for running
 - GM. Stop key for running
 - GN. Stop key for running
 - GO. Stop key for running
 - GP. Stop key for running
 - GQ. Stop key for running
 - GR. Stop key for running
 - GS. Stop key for running
 - GT. Stop key for running
 - GU. Stop key for running
 - GV. Stop key for running
 - GW. Stop key for running
 - GX. Stop key for running
 - GY. Stop key for running
 - GA. Stop key for running
 - GB. Stop key for running
 - GC. Stop key for running
 - GD. Stop key for running
 - GE. Stop key for running
 - GF. Stop key for running
 - GG. Stop key for running
 - GH. Stop key for running
 - GI. Stop key for running
 - GJ. Stop key for running
 - GK. Stop key for running
 - GL. Stop key for running
 - GM. Stop key for running
 - GN. Stop key for running
 - GO. Stop key for running
 - GP. Stop key for running
 - GQ. Stop key for running
 - GR. Stop key for running
 - GS. Stop key for running
 - GT. Stop key for running
 - GU. Stop key for running
 - GV. Stop key for running
 - GW. Stop key for running
 - GX. Stop key for running
 - GY. Stop key for running
 - GA. Stop key for running
 - GB. Stop key for running
 - GC. Stop key for running
 - GD. Stop key for running
 - GE. Stop key for running
 - GF. Stop key for running