

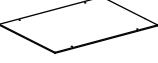

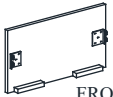

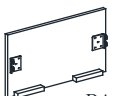

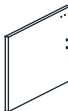

ASSEMBLY INSTRUCTION

NO	PARTLIST	QTY
1	 TOP PANEL	1PC
2	 BOTTOM PANEL	1PC
3	 FRONT PANEL	1PC
4	 BACK PANEL	1PC
5	 SIDE PANEL (L)	1PC
6	 SIDE PANEL (R)	1PC

ITEM	HARDWARE	QTY
A	 JCBB SCREW M8 x 16MM	8PCS
B	 JCBC SCREW M6 x 16MM	8PCS
C	 HINGES (LEFT)	1PC
D	 HINGES (RIGHT)	1PC
E	 SCREW M4 x 16MM	4PCS
F	 L - KEY M4 x 65MM	1PC
G	 L - KEY M5 x 65MM	1PC

STEP 1

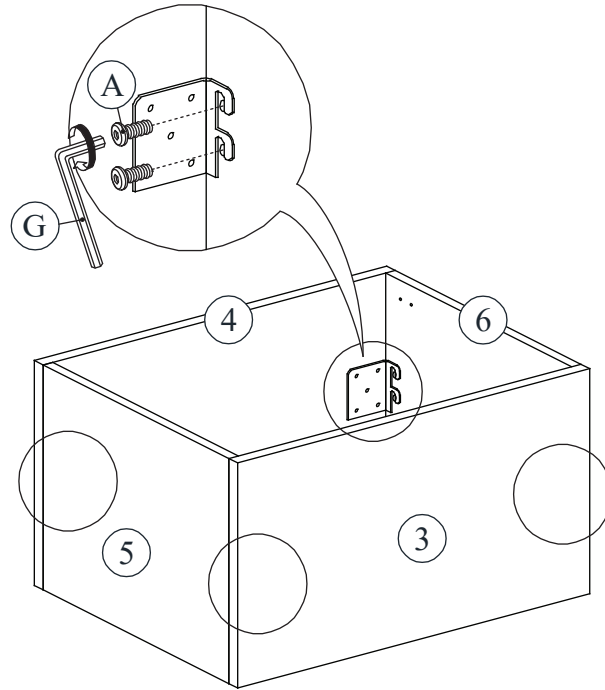

STEP 2

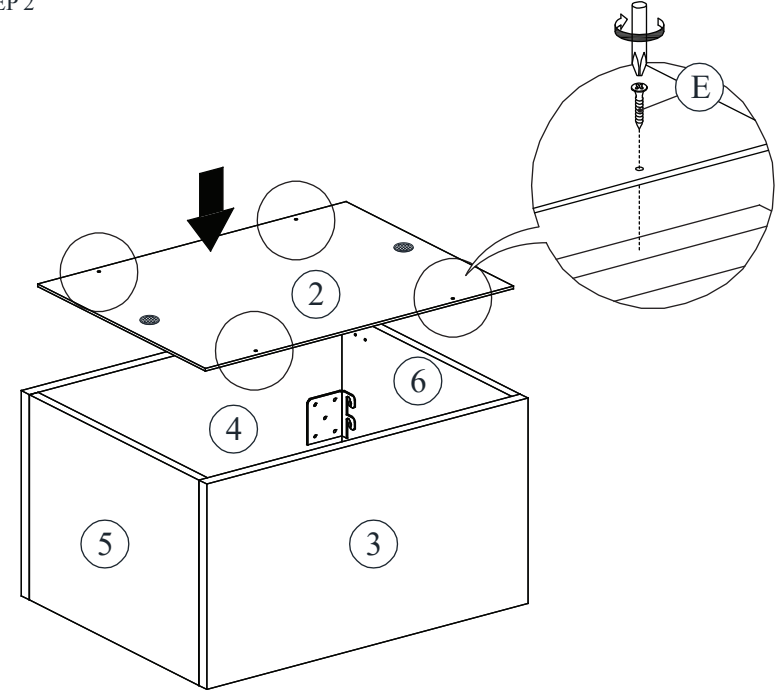

STEP 3

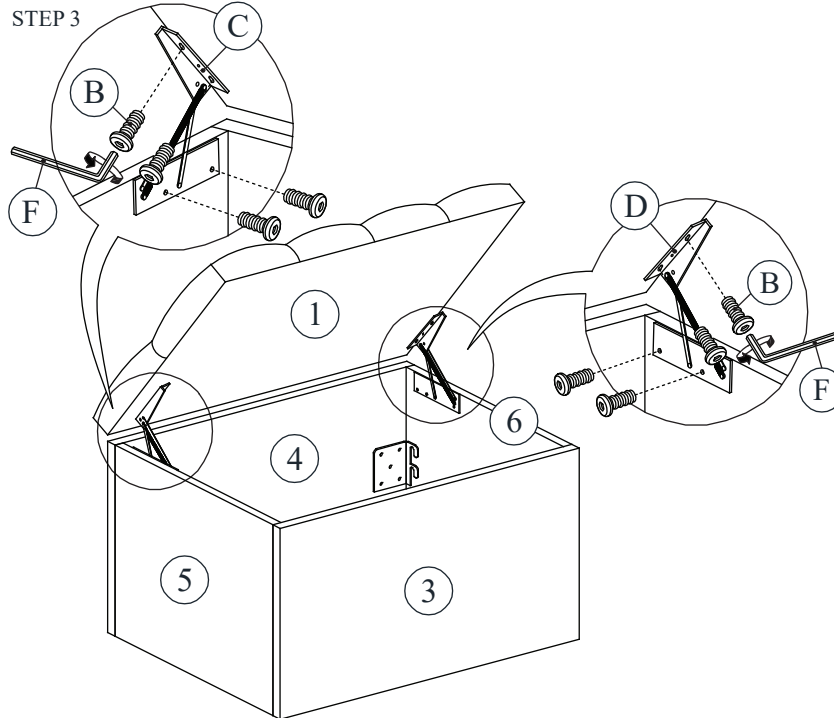

STEP 4

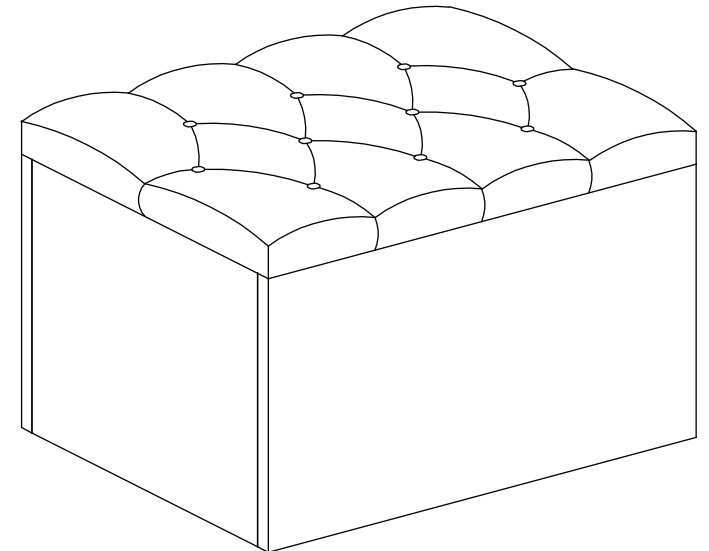

ASSEMBLY
COMPLETED