

ASSEMBLY INSTRUCTION

SKU CODE:N709P204631K / N709P204632K
N709P204631H / N709P204632H

INSTRUCTIONS DE MONTAGE

CODE UGS :N709P204631K / N709P204632K
N709P204631H / N709P204632H

TWIN SIZE DAYBED WITH TRUNDLE LIT DE JOUR DOUBLE AVEC LIT GIGOGNE

This set included 2 boxex if do not receive full 2 boxex. Please contact our customer service team

Cet ensemble comprenait 2 boxex si vous ne recevez pas 2 boxex complets. Veuillez contacter notre service client

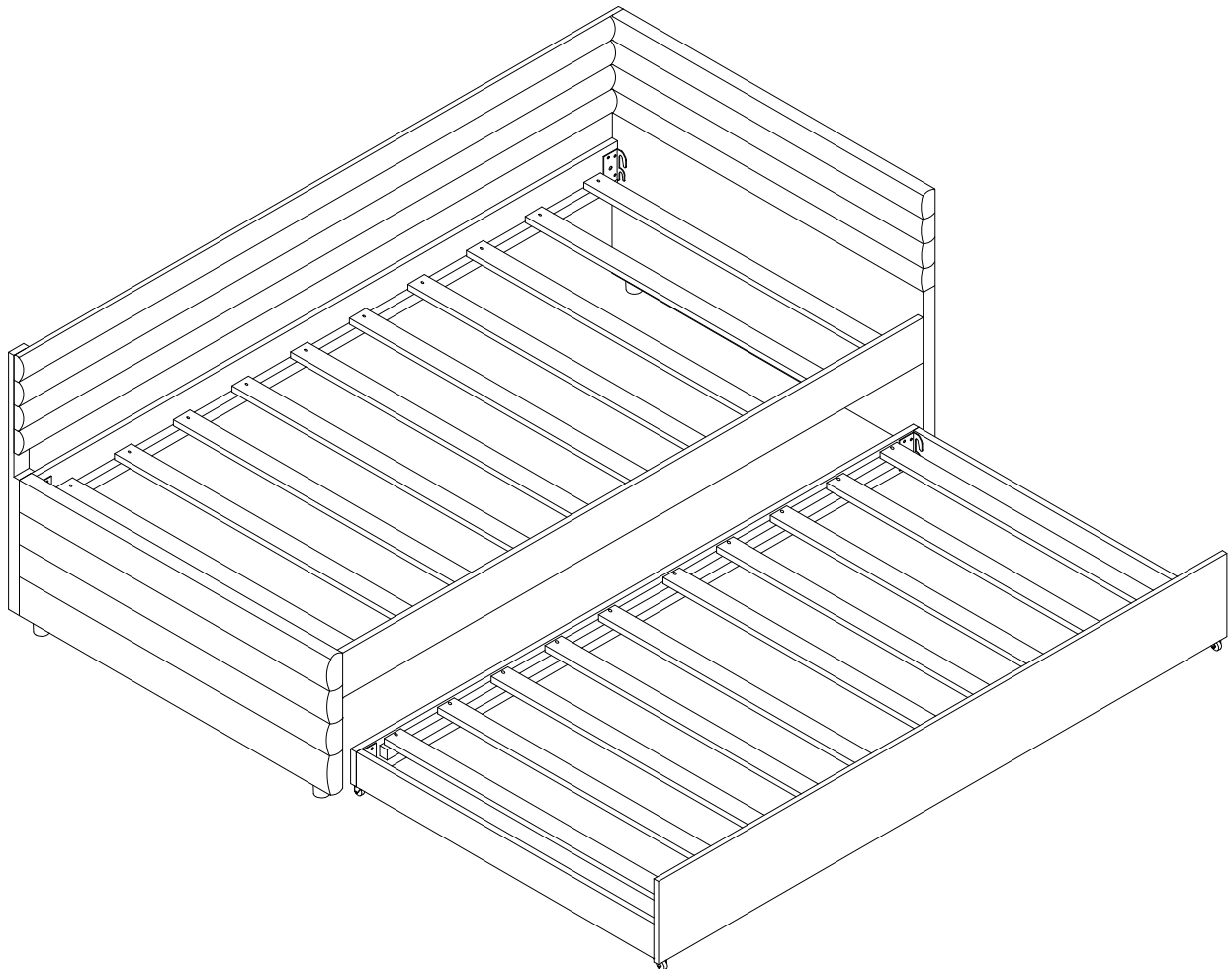

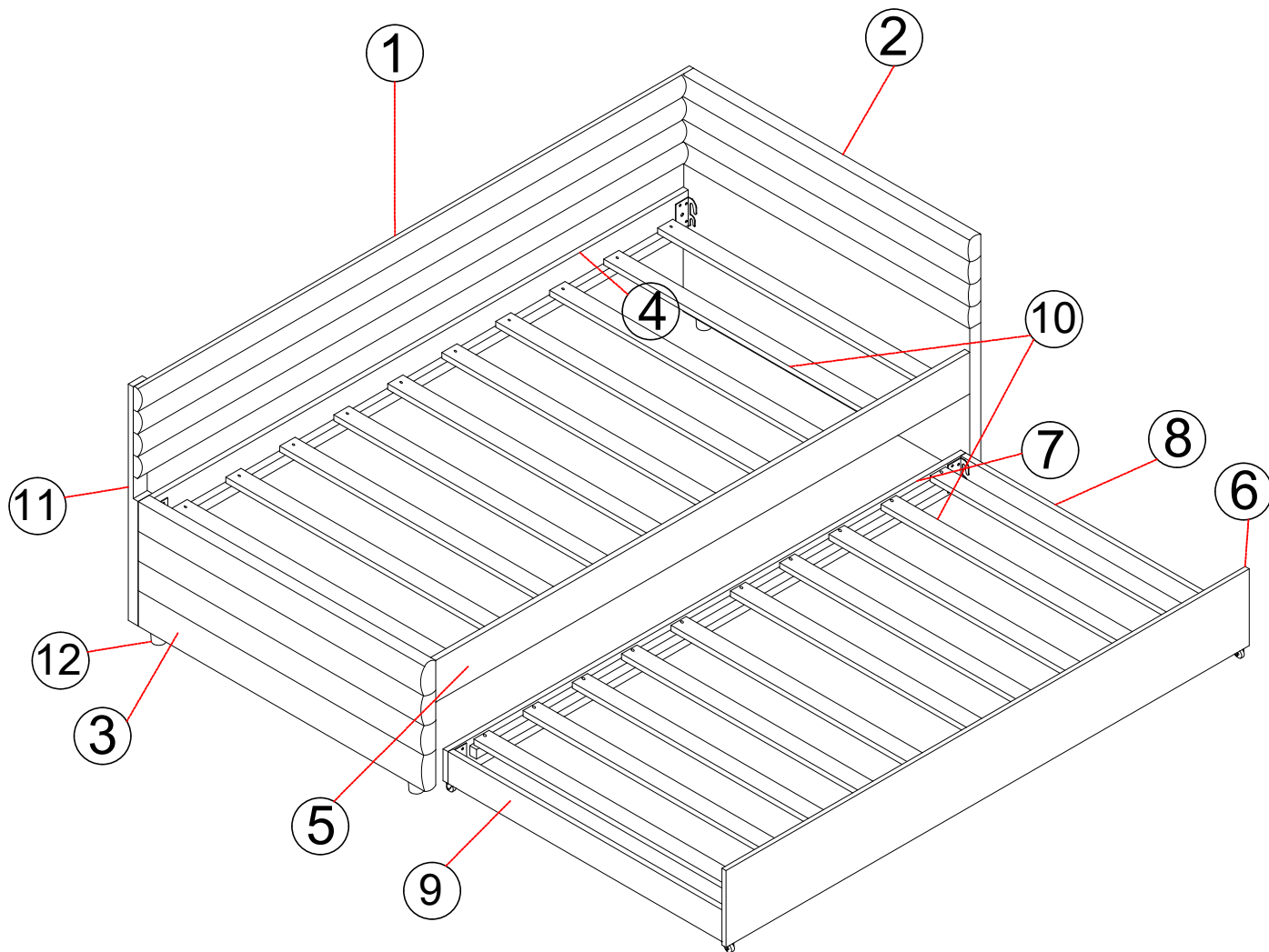

Part List

(Liste des pièces)

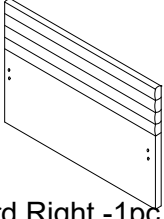
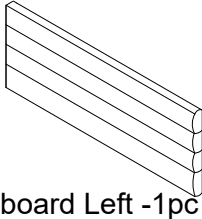
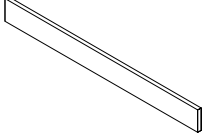
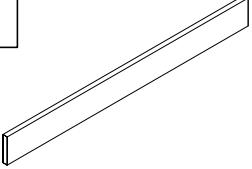
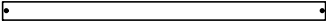

BOX 1/2: N709P204631K/ N709P204631H

ENCADRÉ 1/2 :N709P204631K / N709P204631H

<p>2</p>  <p>Side board Right -1pc Buffet latéral Droit -1 pièce</p>	<p>3</p>  <p>Side board Left -1pc Buffet latéral gauche - 1 pièce</p>	<p>8</p>  <p>lower right support - 01 pc (support en bas à droite -01pièce)</p>
<p>9</p>  <p>Lower left support - 01 pc Support inférieur gauche -01pc</p>	<p>10</p>  <p>Slates-20pcs BARRES DE SUPPORT - 20 PCS</p>	

BOX 2/2: N709P204632K / N709P204632H

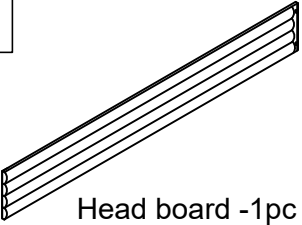
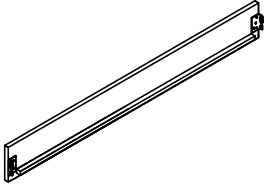
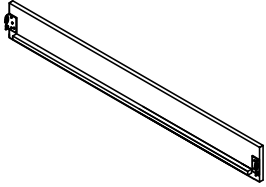
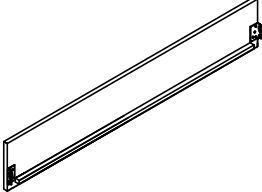
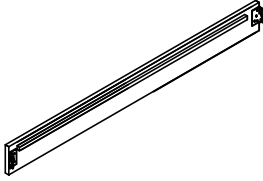

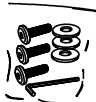



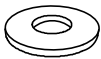

ENCADRÉ 1/2 : N709P204632K / N709P204632H

<p>1</p>  <p>Head board -1pc Tête de lit - 1 pièce</p>	<p>4</p>  <p>Back Rails -1pc Dos de barrière - 1 pièce</p>	<p>5</p>  <p>Front Rails -1pc Rails avant - 1 pièce</p>
<p>6</p>  <p>drawer front -1pc Facade de tiroir - 1 pièces</p>	<p>7</p>  <p>support behind the drawer -1pc support derrière les tiroirs -1 pièce</p>	<p>11</p>  <p>connecting rod -1pc bielle - 1 pièce</p>
<p>12</p>  <p>Legs - 4pcs (JAMBE-4pcs)</p>	<p>Hardware (Matériel)</p> 	

HARDWARE

Check that you've received
all hardware listed below.

Hardware List (Liste du matériel)

No.	OUTLOOK (PERSPECTIVES)	NOTE	QTY
(A)		Bolts 5/16"x35 mm (Boulons 5/16"x35 mm)	6
(B)		Bolts 5/16"x30 mm (Boulons 5/16"x30 mm)	22
(C)		Spring washer Ø5/16"x12 mm (Rondelle élastiquer Ø5/16"x12 mm)	22
(D)		Allen key 80x25x4 mm (clé Alle`n 80x25x4 mm)	1
(E)		Bolts 5/16"x30 mm (Boulons 5/16"x30 mm)	8
(K)		Bolts 5/16"x20 mm (Boulons 5/16"x20 mm)	8
(G)		Screws Ø4x15 mm (Des vis Ø4x15 mm)	8
(F)		Screws Ø4x30 mm (Des vis Ø4x30 mm)	40
(H)		Wheel (Roue)	4

STEP 1 (ÉTAPE 1)

⑫x2	E x 4	B x 4	C x 4

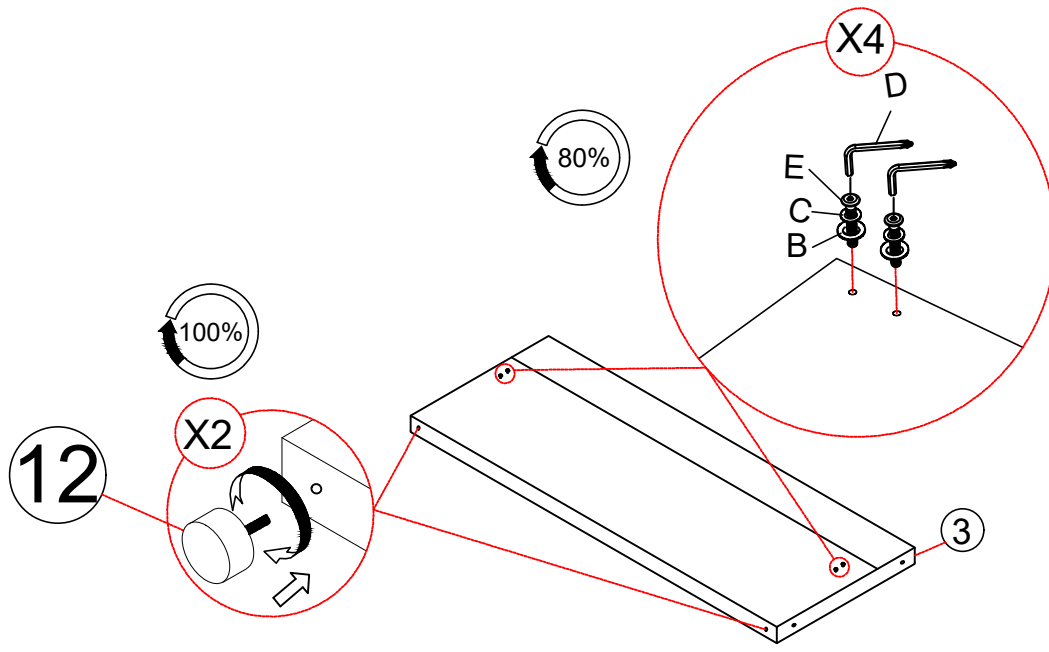

STEP 2 (ÉTAPE 2)

⑫x2	E x 4	B x 4	C x 4

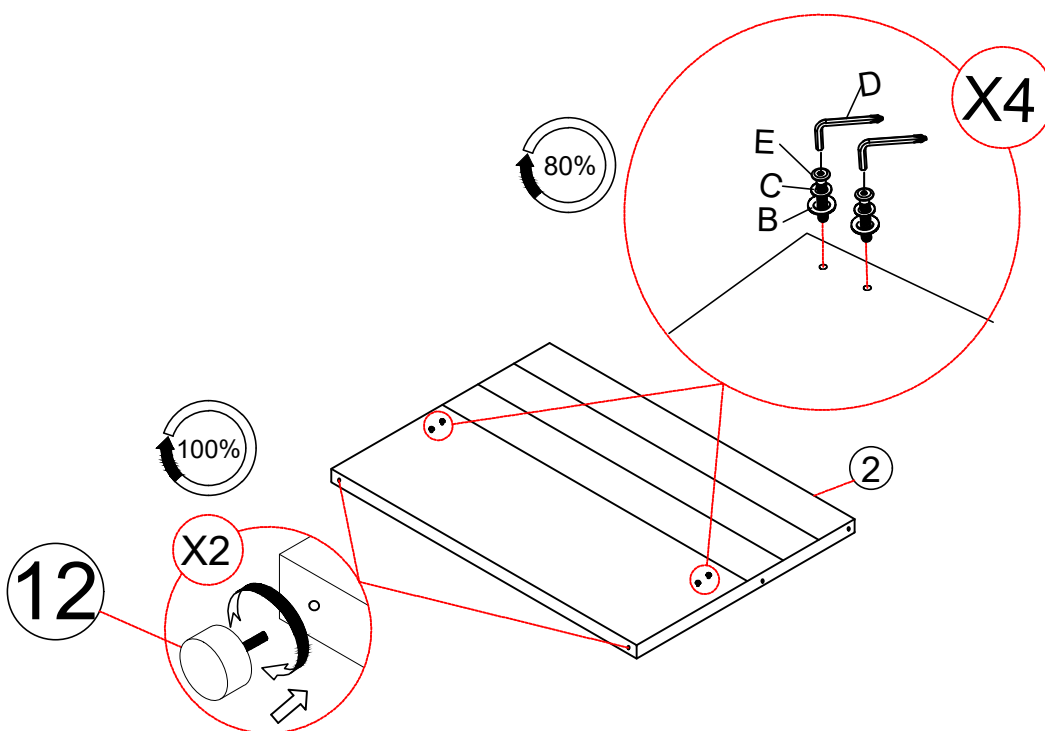

STEP 3

(ÉTAPE 3)

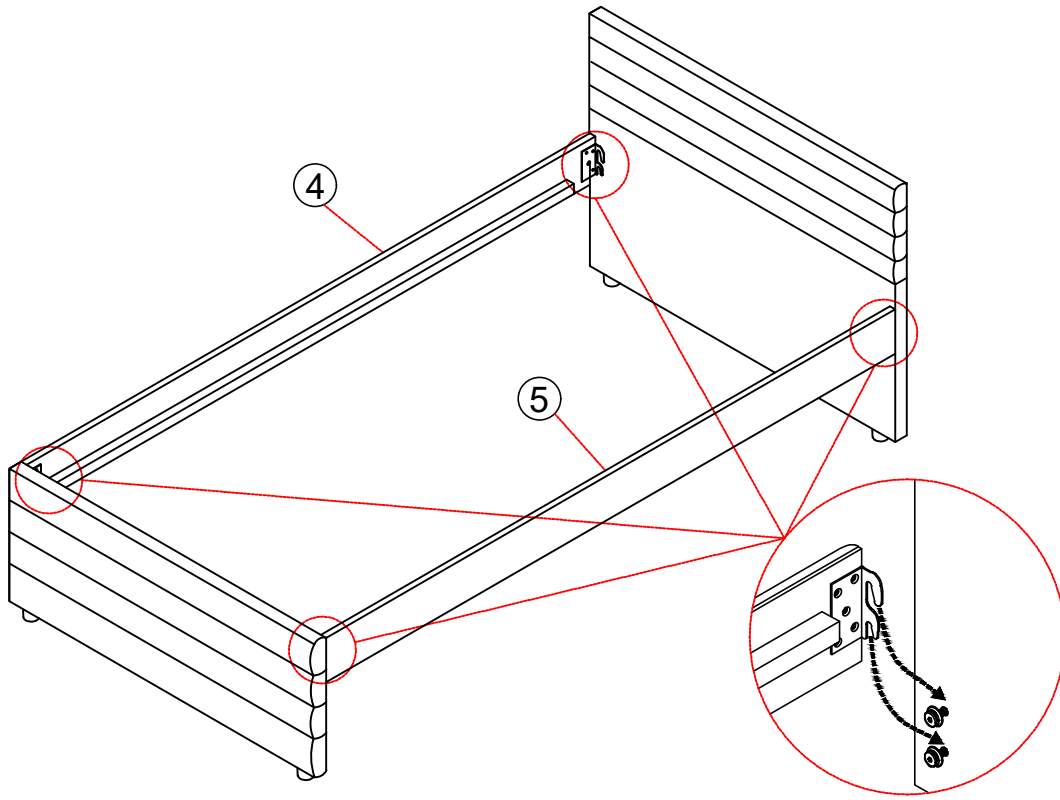

STEP 4

(ÉTAPE 4)

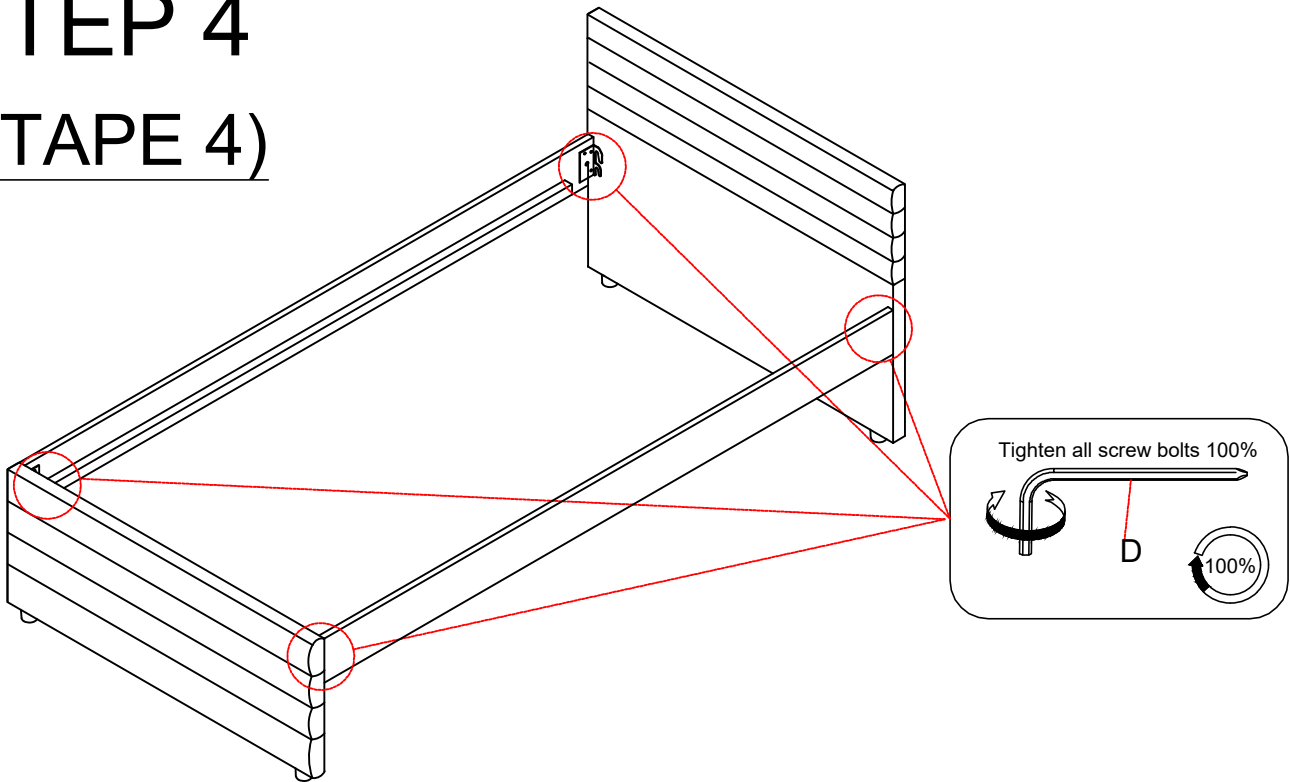

STEP 5 (ÉTAPE 5)

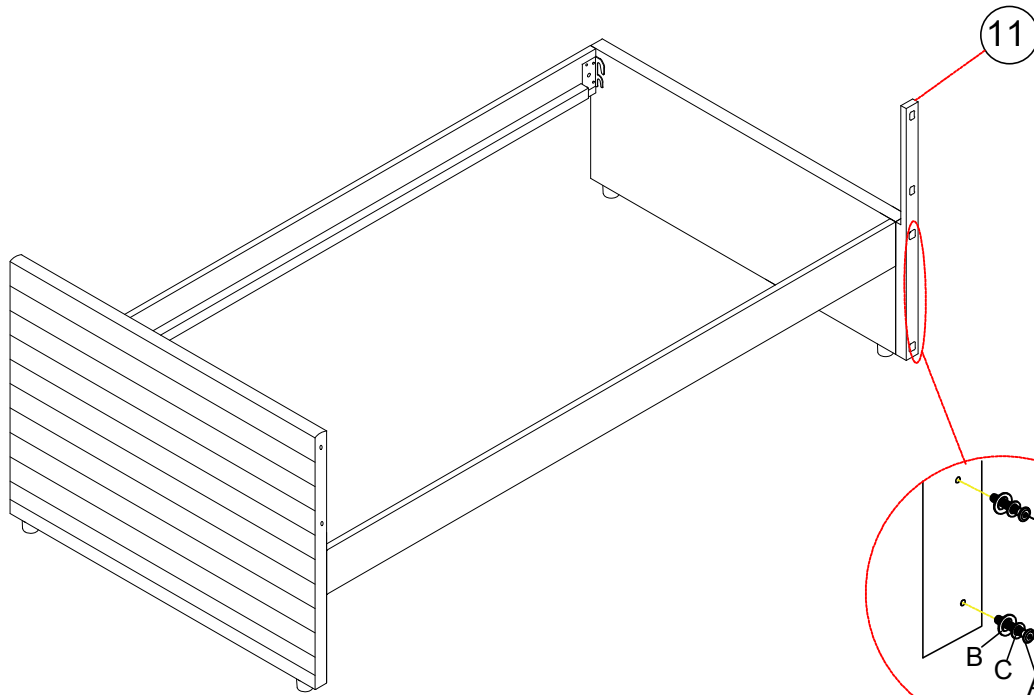
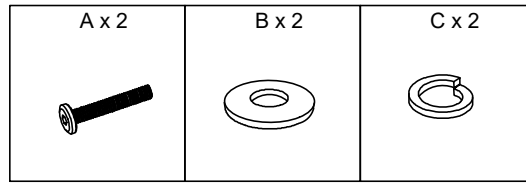

STEP 6 (ÉTAPE 6)

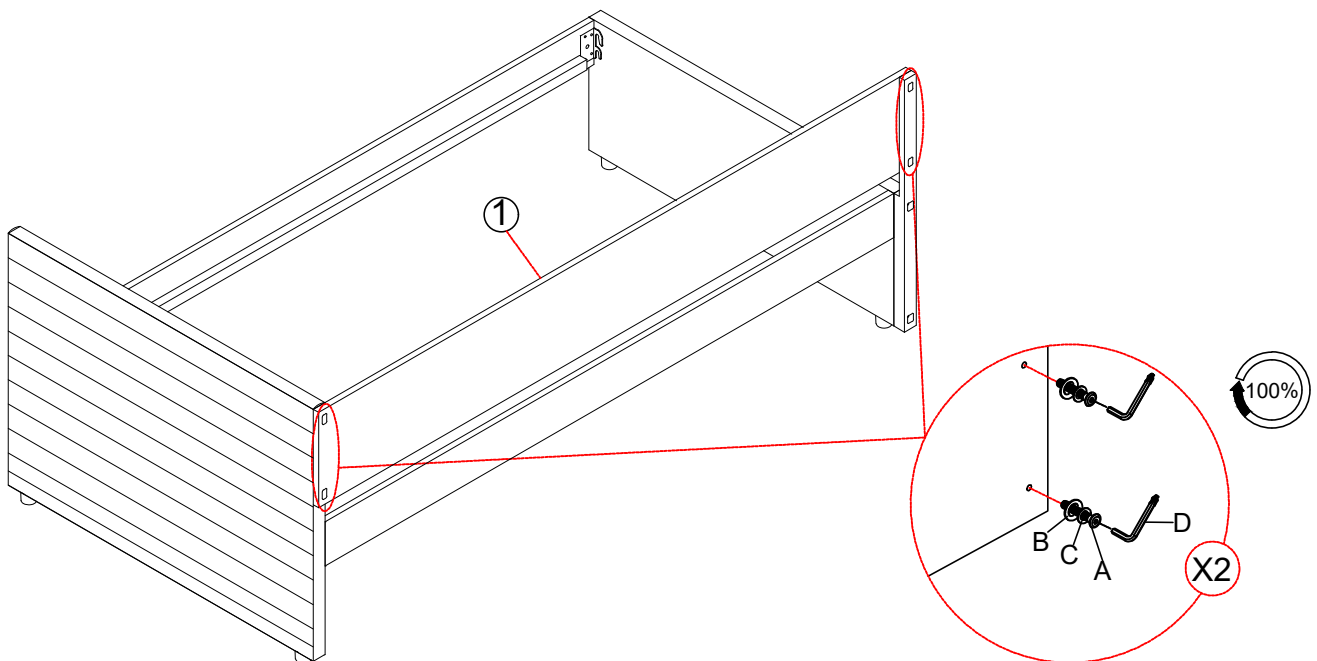
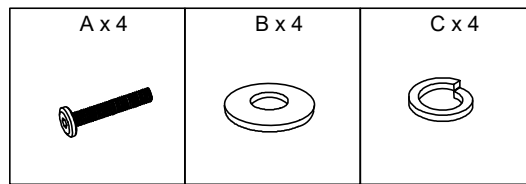

STEP 7 (ÉTAPE 7)

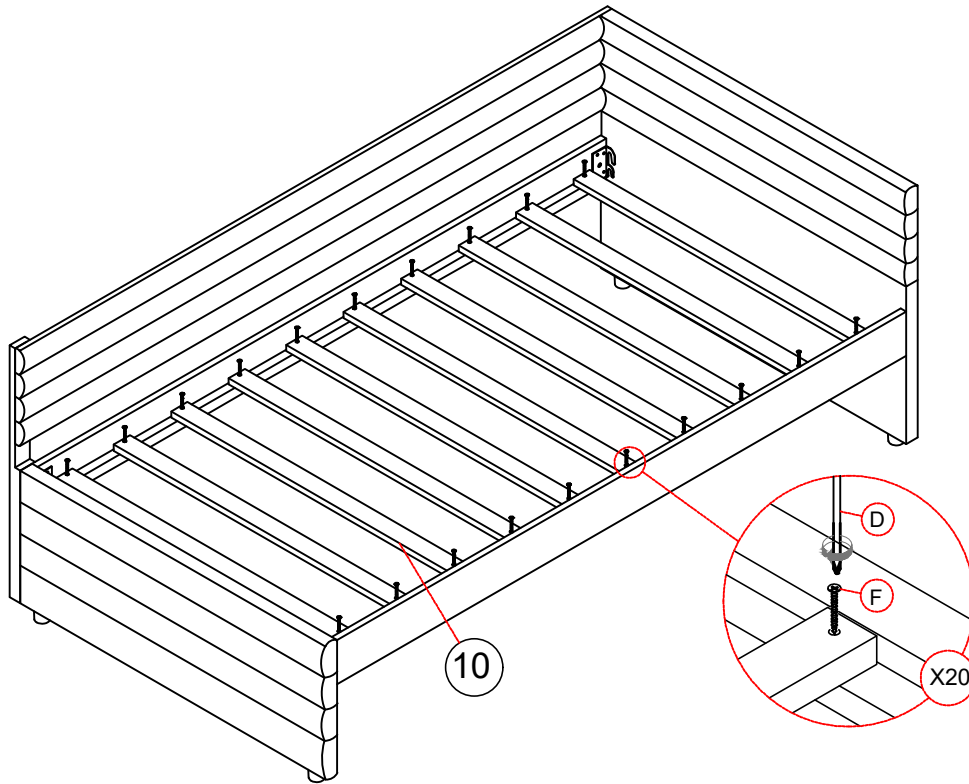
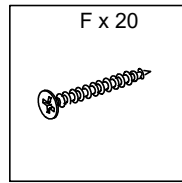

STEP 8 (ÉTAPE 8)

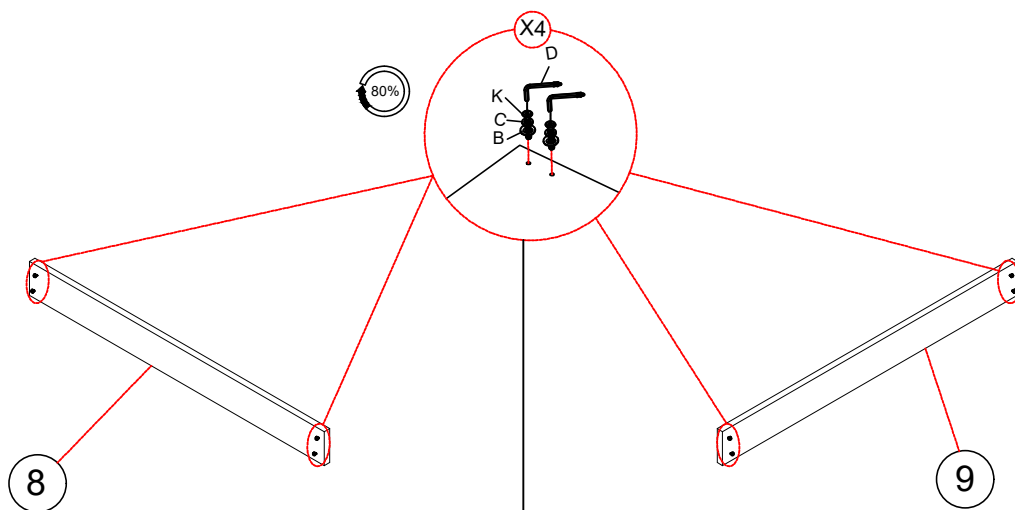
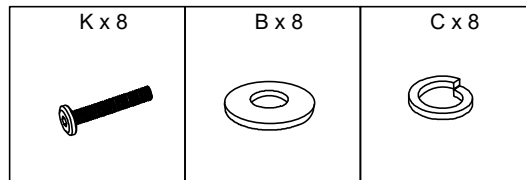

STEP 9

(ÉTAPE 9)

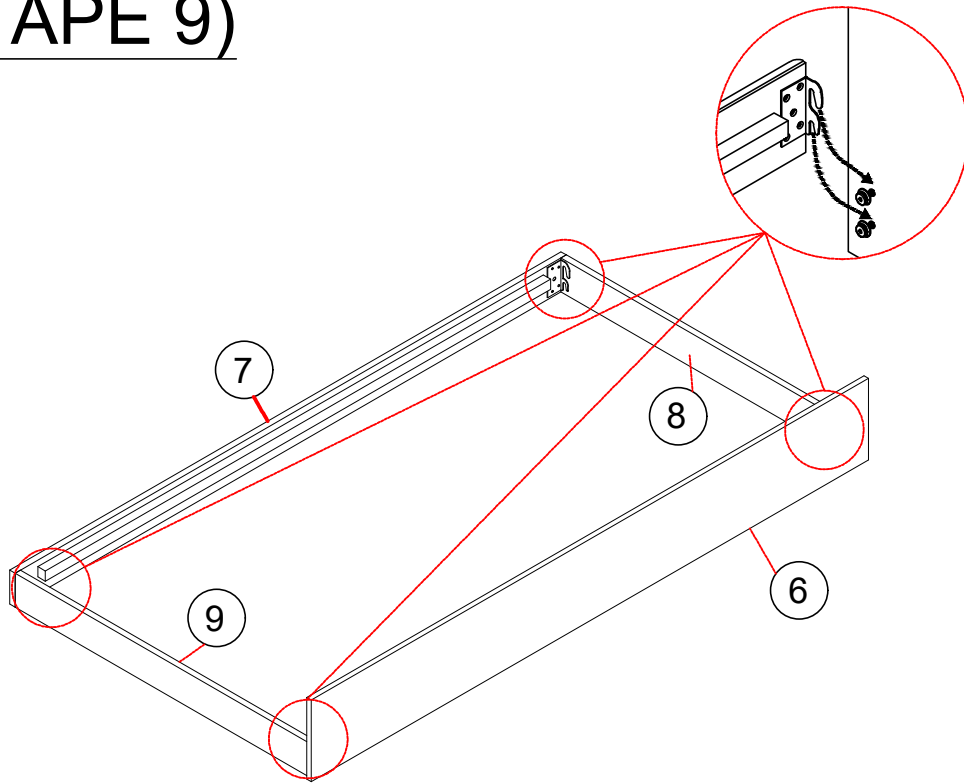

STEP 10

(ÉTAPE 10)

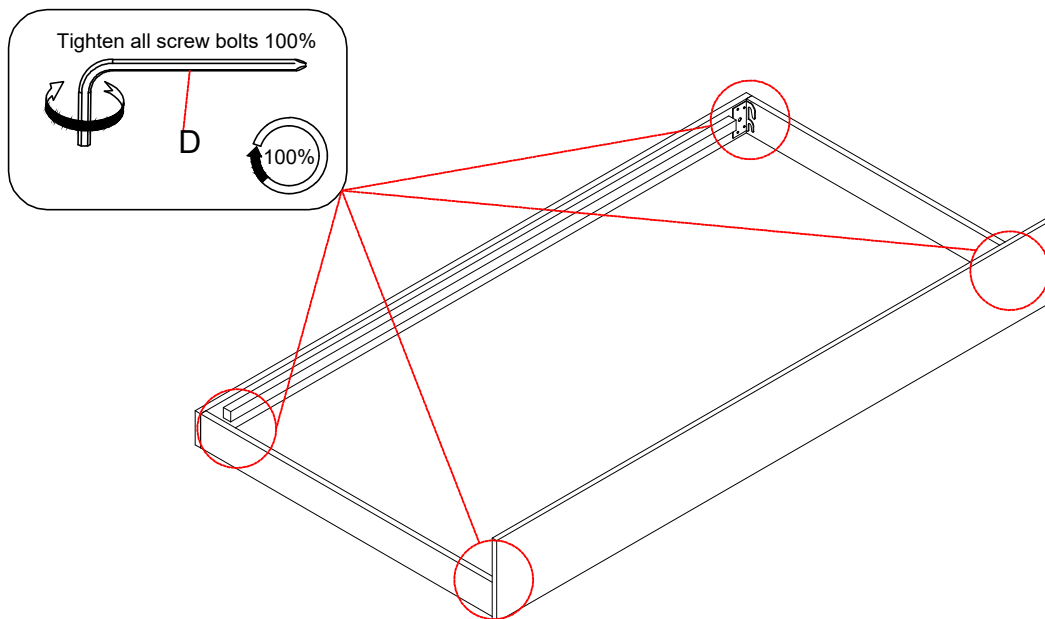

STEP 11 (ÉTAPE 11)

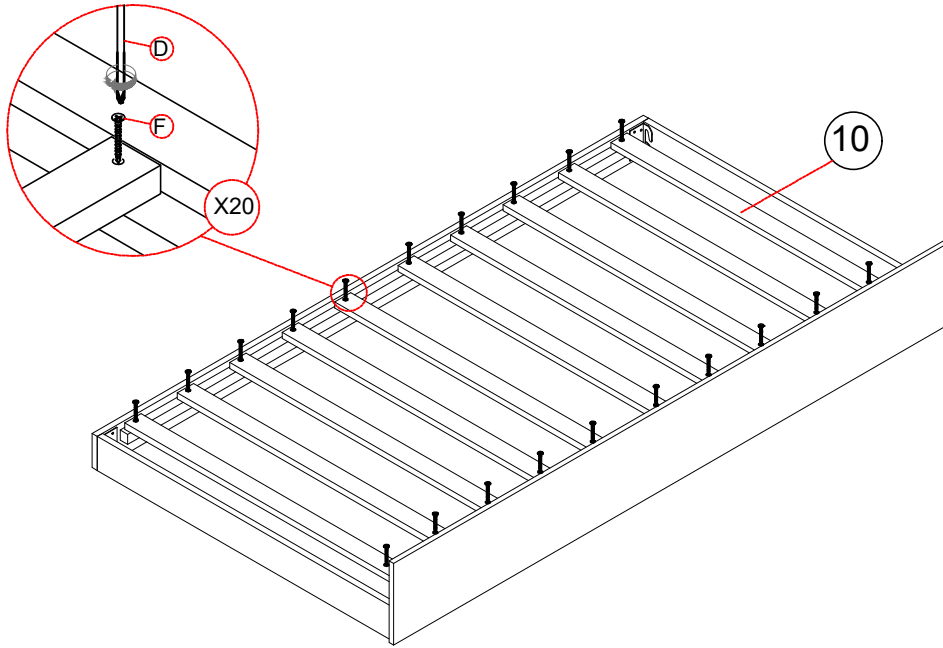
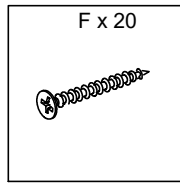

STEP 12 (ÉTAPE 12)

