

80113-311/321/331/341/511/521/531/541 ASSEMBLY INSTRUCTION

Thank you for purchasing this quality product. Be sure to check all packing material carefully for small parts which may have come loose inside the carton during shipment. Separate, identify and count all parts and hardware. Compare with the parts list to be sure all parts are present.

IMPORTANT : PLEASE READ INSTRUCTION BEFORE STARTING THE ASSEMBLY.

"DO NOT TIGHTEN SCREWS UNTIL COMPLETELY ASSEMBLED"

"DO NOT OVERTIGHT ANY HARDWARE"

WARNING : SMALL PARTS AND HARDWARE NOT FOR CHILDREN UNDER 3 YEARS. ADULT ASSEMBLY REQUIRED.

TABLE OF CONTENTS

HARDWARES LIST	PAGE 2
PARTS LIST	PAGE 3 - 4
PARTS' LOCATION	PAGE 5
ASSEMBLY STEPS	PAGE 6 - 14
ASSEMBLY COMPLETED	PAGE 15

ASSEMBLY TOOLS REQUIRED

1. Screwdriver (not provide)



2. Hammer (not provide)











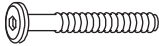



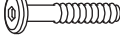
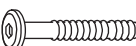

Skip the power trip this time.



80113-311/321/331/341/511/521/531/541 ASSEMBLY INSTRUCTION

HARDWARES LIST

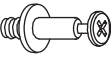
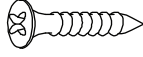
ITEM	DESCRIPTION	DRAWING	QTY
A	JCBC SCREW M8 x 70MM		4 PCS
B	WOOD DOWEL M10 x 30MM		4 PCS
C	JCBC SCREW M6 x 15MM		16 PCS
D	JCBC SCREW M6 x 20MM		12 PCS
E	JCBC SCREW M6 x 35MM		6 PCS
F	JCBC SCREW M6 x 50MM		2 PCS
G	SPRING WASHER M6 x 12MM		8 PCS
H	FLAT WASHER M6 x 19MM		8 PCS
I	SPRING WASHER M8 x 13MM		4 PCS
J	FLAT WASHER M8 x 22MM		4 PCS
K	M4 ALLEN KEY (100MM)		1 PC
L	M5 ALLEN KEY (65MM)		1 PC
M	SUPPORT LEG ADJUSTABLE FEET		4 PCS
FOR INNER BOX PACKING			
N	WOOD DOWEL M6 x 30MM		64 PCS
O	MINIFIX CAM LOCK		32 PCS
P	MINIFIX BOLT		32 PCS
Q	CSK C/B SCREW (M4 x 16MM)		64 PCS

80113-311/321/331/341/511/521/531/541 ASSEMBLY INSTRUCTION



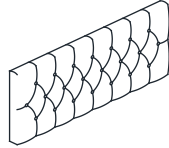
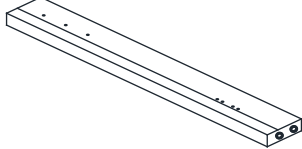
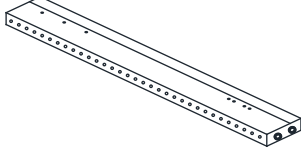
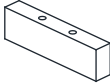
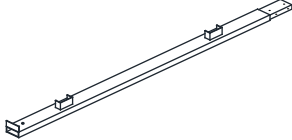
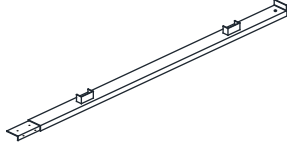
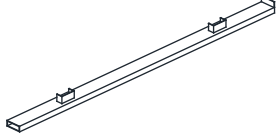
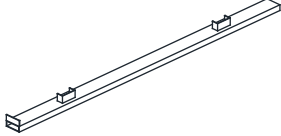
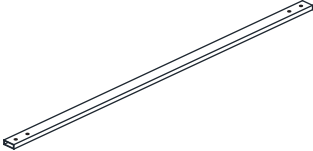
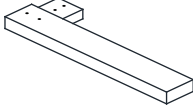
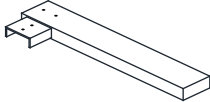



PARTS LIST

ITEM	DESCRIPTION	DRAWING	QTY
1	HEADBOARD		1 PC
2	WING (L)		1 PC
3	WING (R)		1 PC
4	WING SUPPORT		2 PCS
5	FRONT SIDE RAIL (L)		1 PC
6	FRONT SIDE RAIL (R)		1 PC
7	BACK SIDE RAIL (L)		1 PC
8	BACK SIDE RAIL (R)		1 PC
9	METAL TUBE		1 PC
10	FOOTBOARD LEG (L)		1 PC
11	FOOTBOARD LEG (R)		1 PC

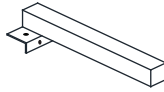
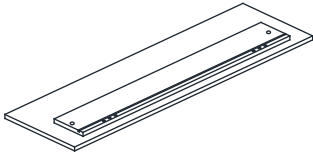
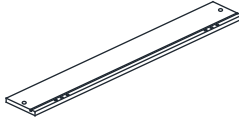
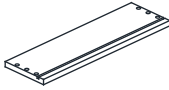
MORE PARTS DETAIL IN NEXT PAGE...

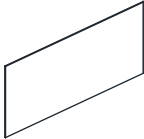
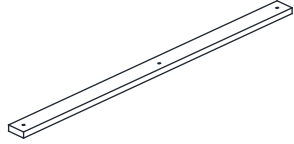
80113-311/321/331/341/511/521/531/541 ASSEMBLY INSTRUCTION

PARTS LIST

ITEM	DESCRIPTION	DRAWING	QTY
12	SIDE RAIL LEG		2 PCS
13	DRAWER FRONT PANEL		4 PCS
14	DRAWER BACK PANEL		4 PCS
15	DRAWER SIDE PANEL		8 PCS
16	DRAWER SUPPORT		8 PCS
17	DRAWER PANEL		4 PCS
18	SLAT		4 PCS
19	SUPPORT LEG WITH HANGER BOLT		4 PCS
20	CASTOR		16 PCS
21	FOOTBOARD COVER		1 PC
24	SELF-ADHESIVE VELCRO TAPE		1 PC

PARTS ' LOCATION

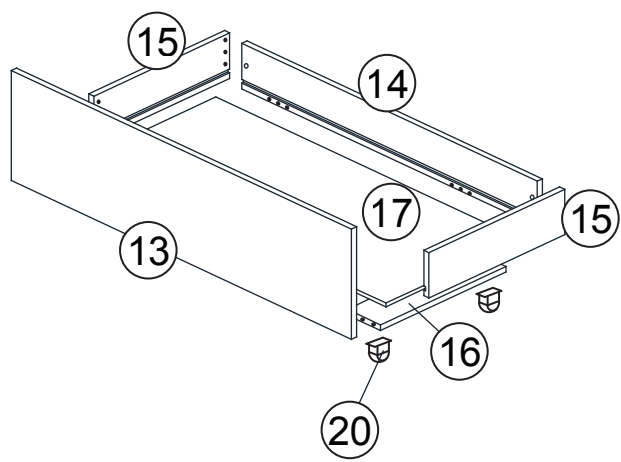
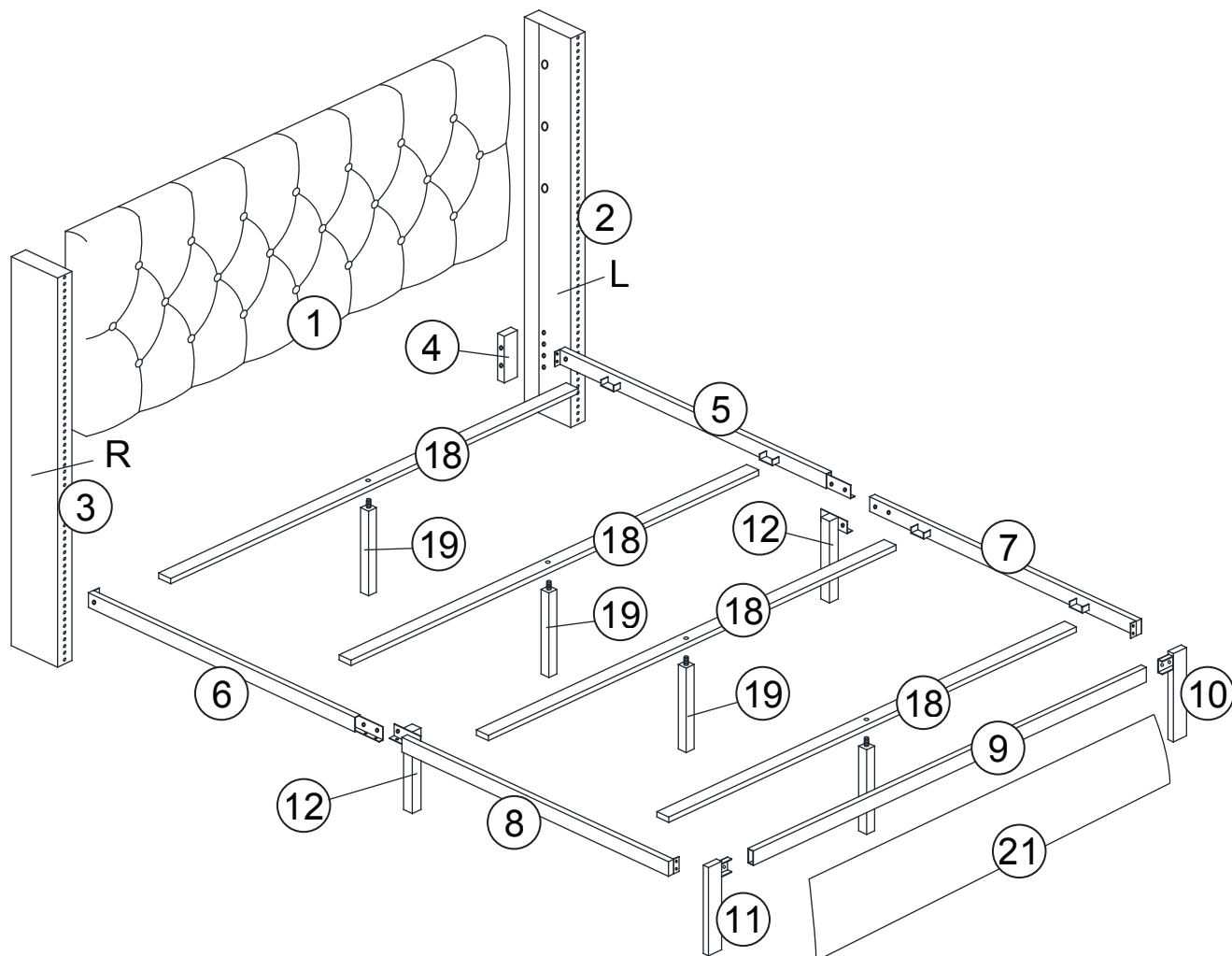

80113-311/321/331/341/511/521/531/541 ASSEMBLY INSTRUCTION

STEP 1

Open zipper to get all other parts.

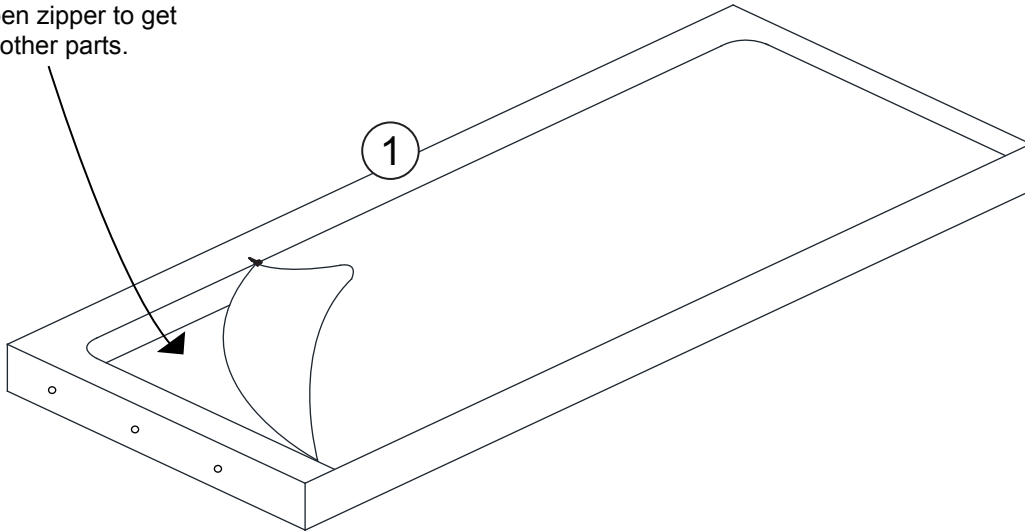

STEP 2

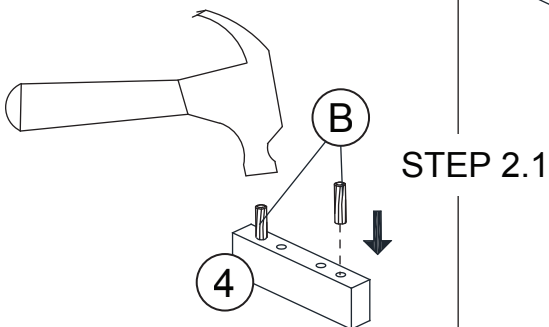
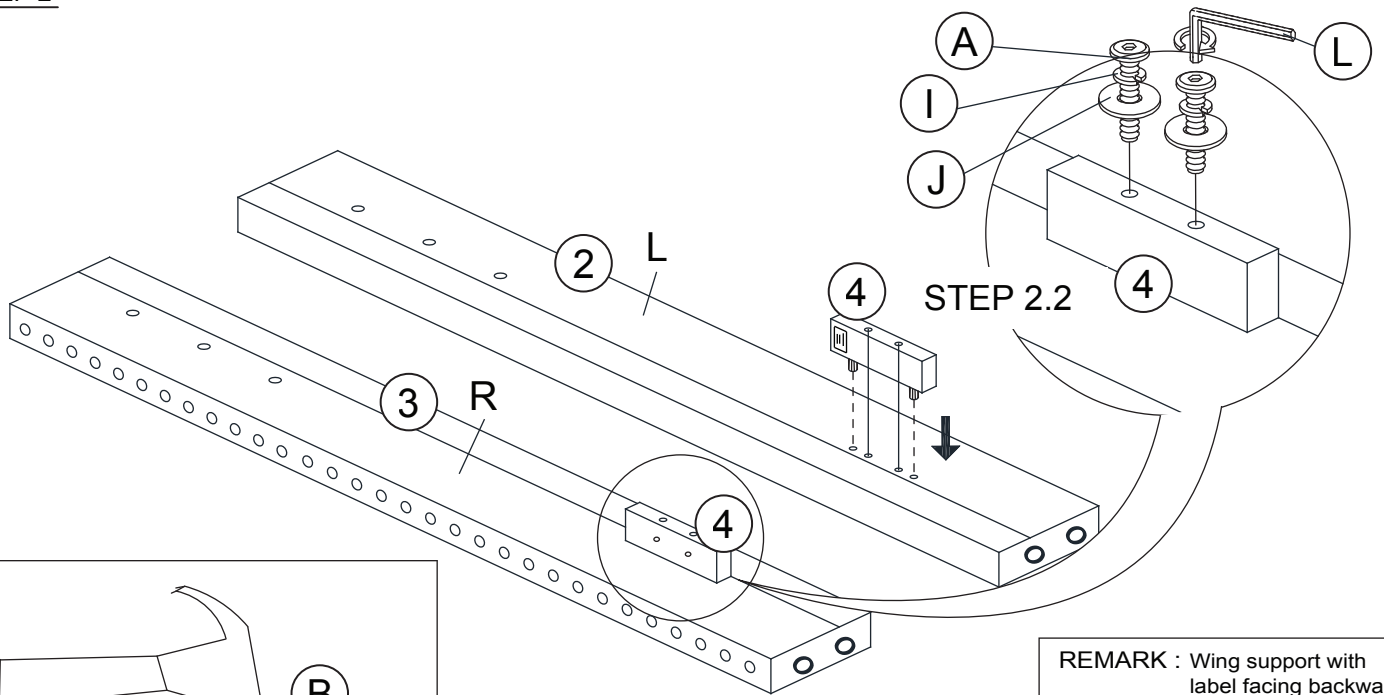

REMARK : Wing support with label facing backward

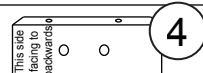

80113-311/321/331/341/511/521/531/541 ASSEMBLY INSTRUCTION

STEP 3

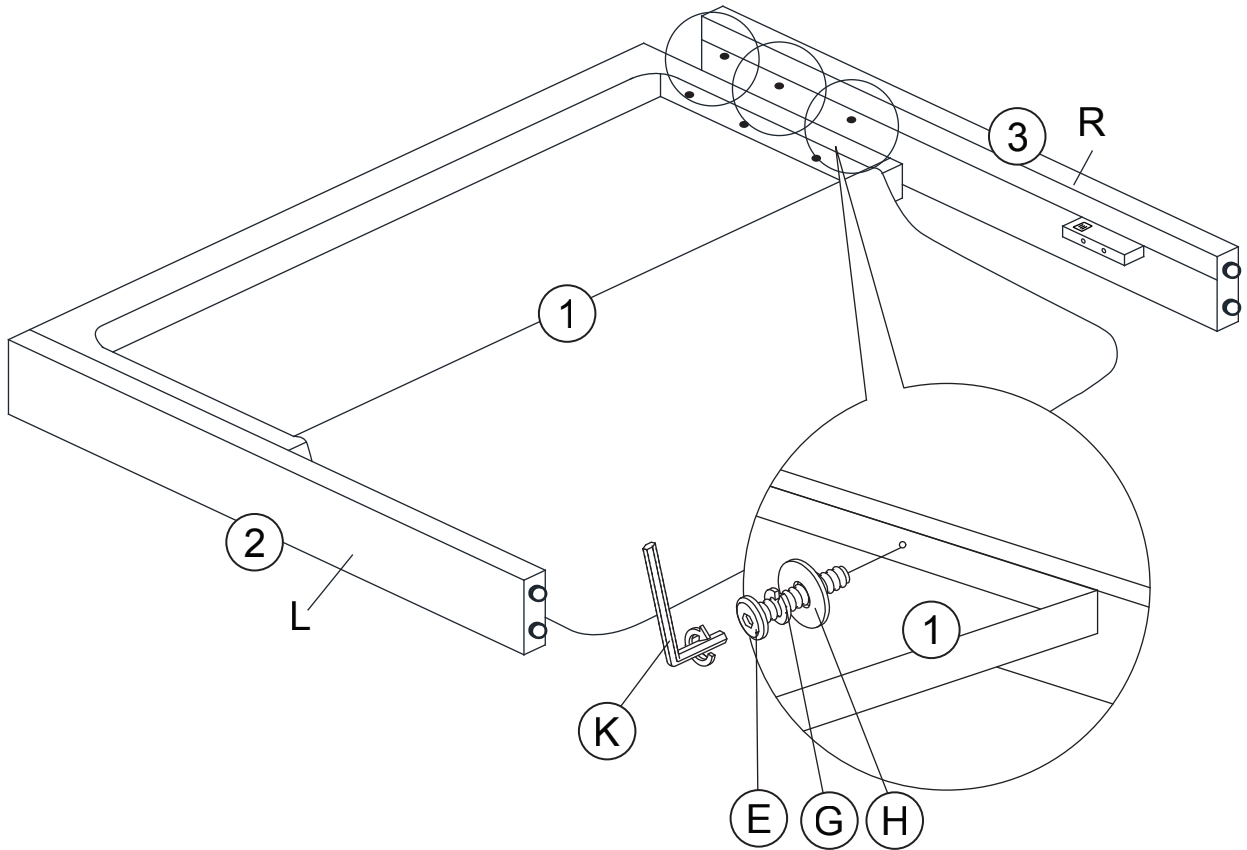

STEP 4

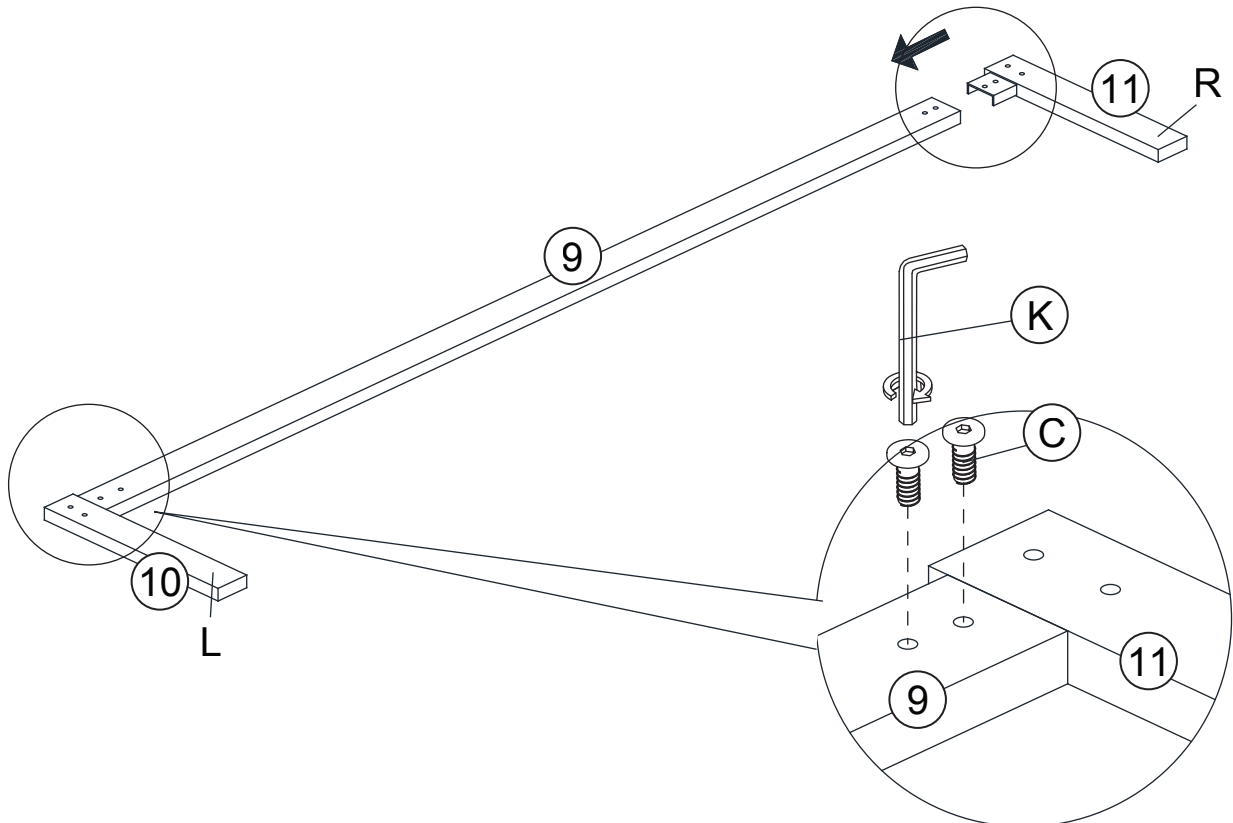

80113-311/321/331/341/511/521/531/541 ASSEMBLY INSTRUCTION

STEP 5

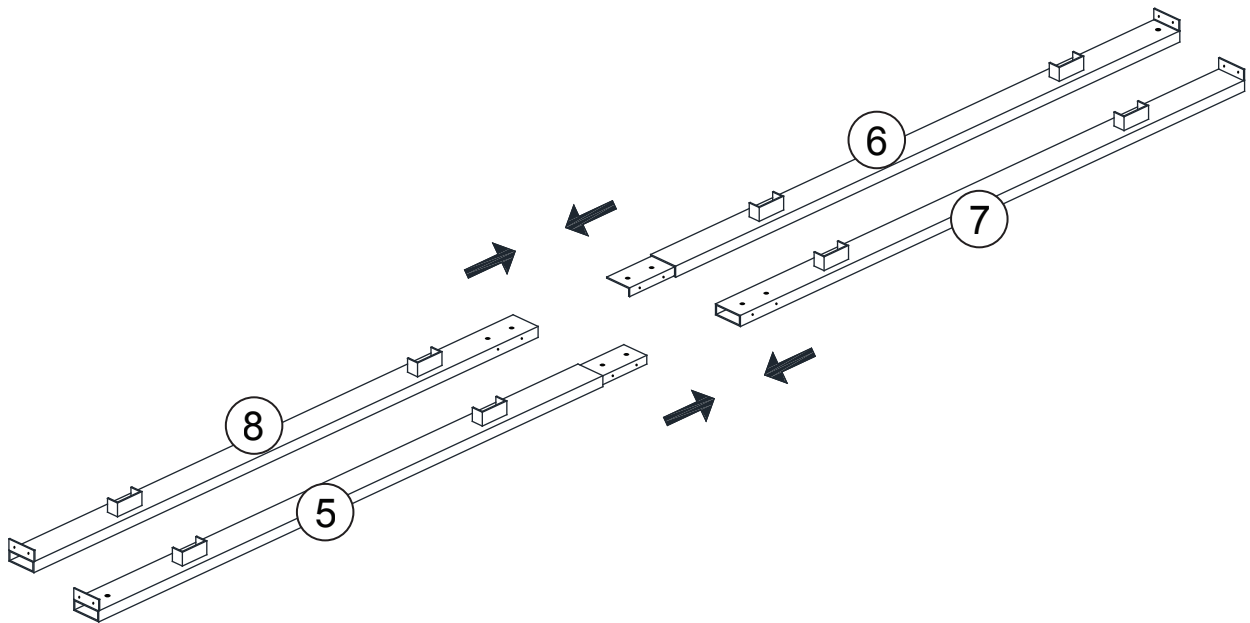

STEP 6

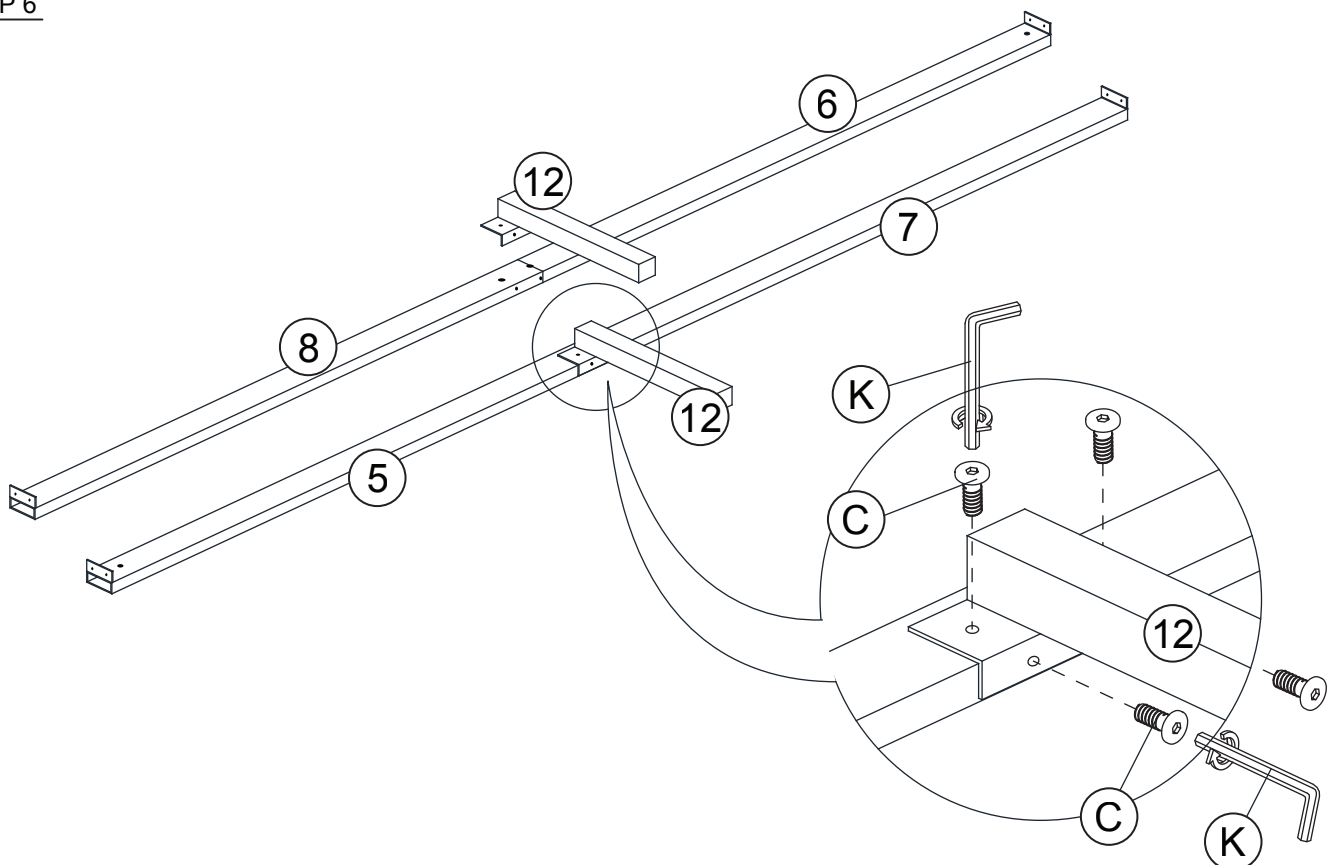

80113-311/321/331/341/511/521/531/541 ASSEMBLY INSTRUCTION

STEP 7

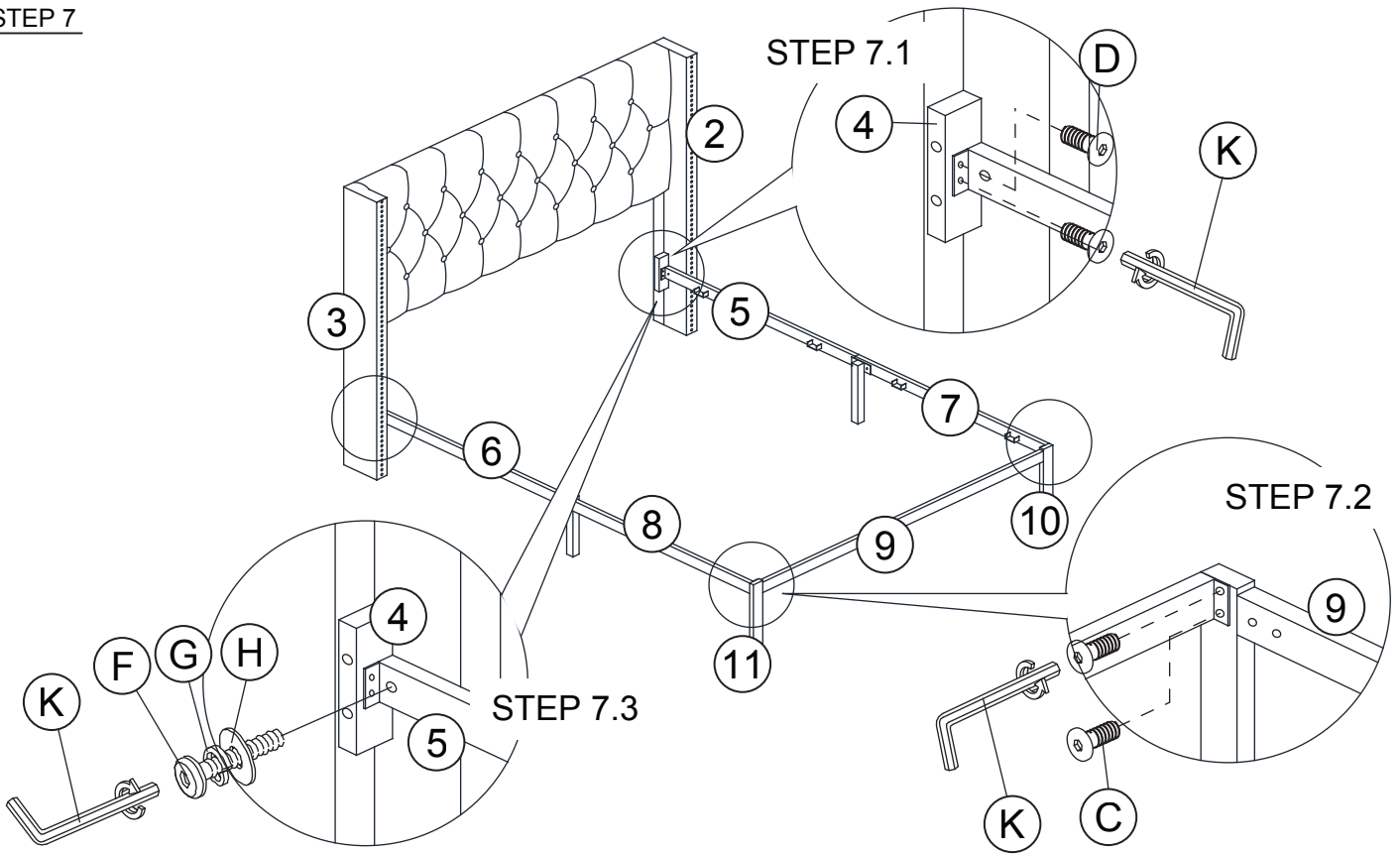

STEP 8

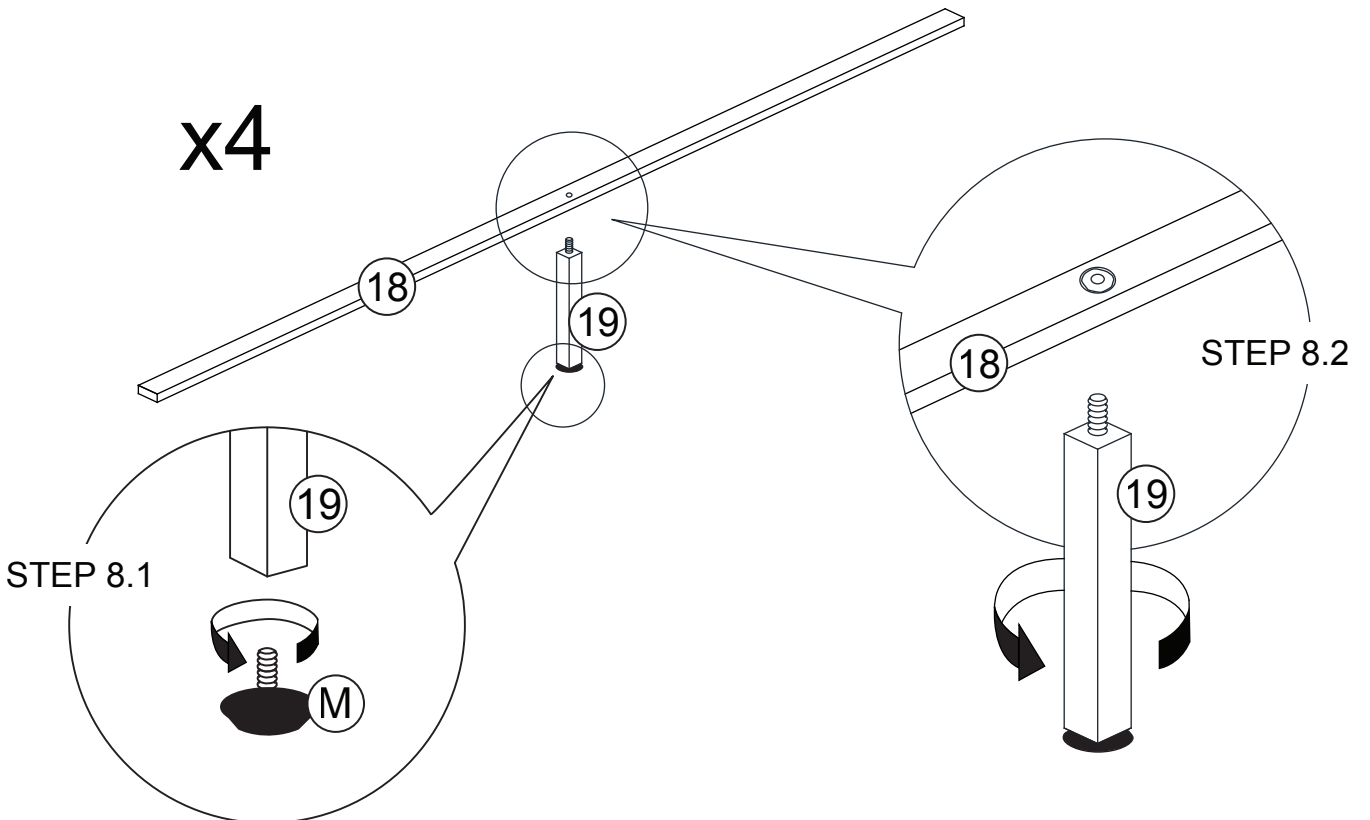

80113-311/321/331/341/511/521/531/541 ASSEMBLY INSTRUCTION

STEP 9

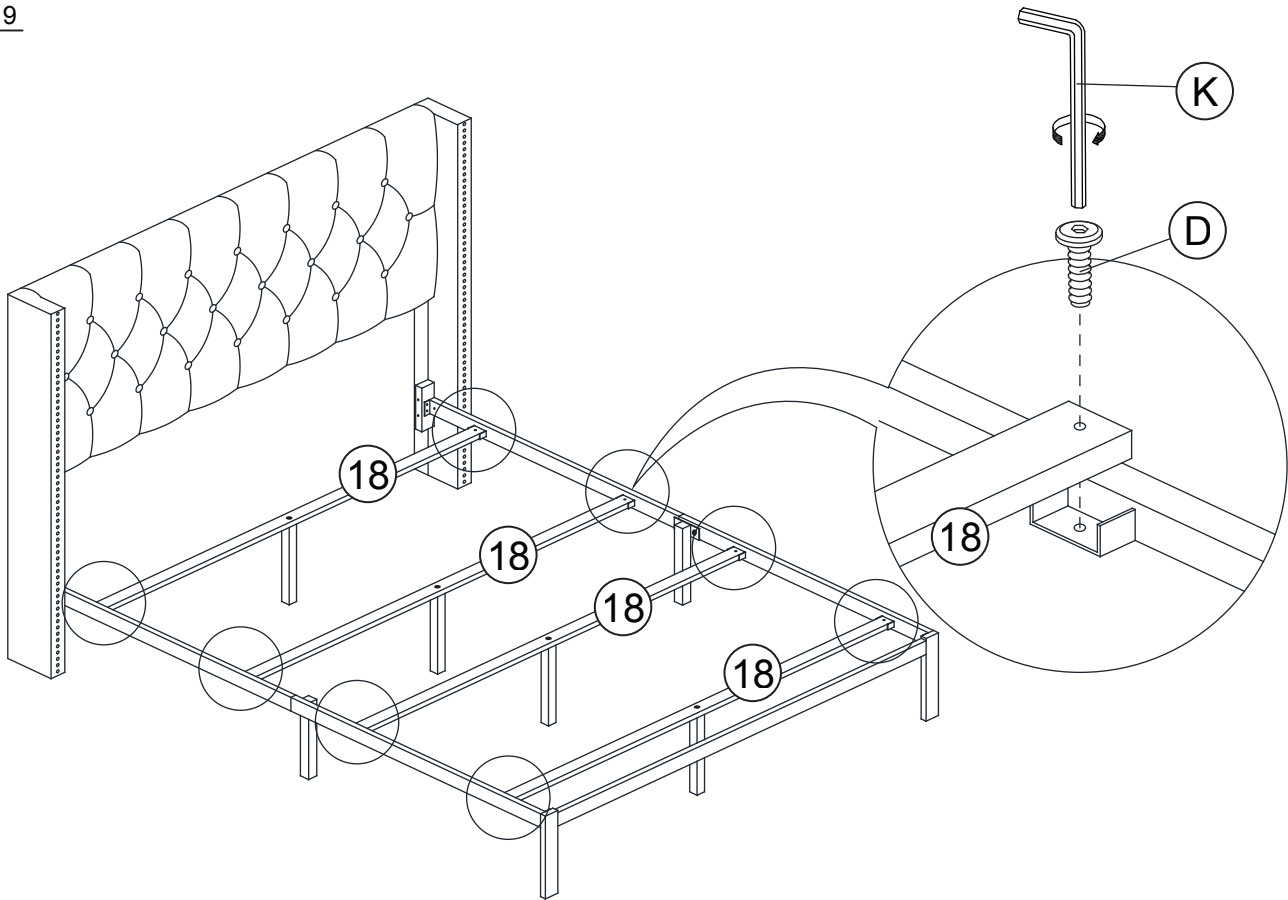

STEP 10

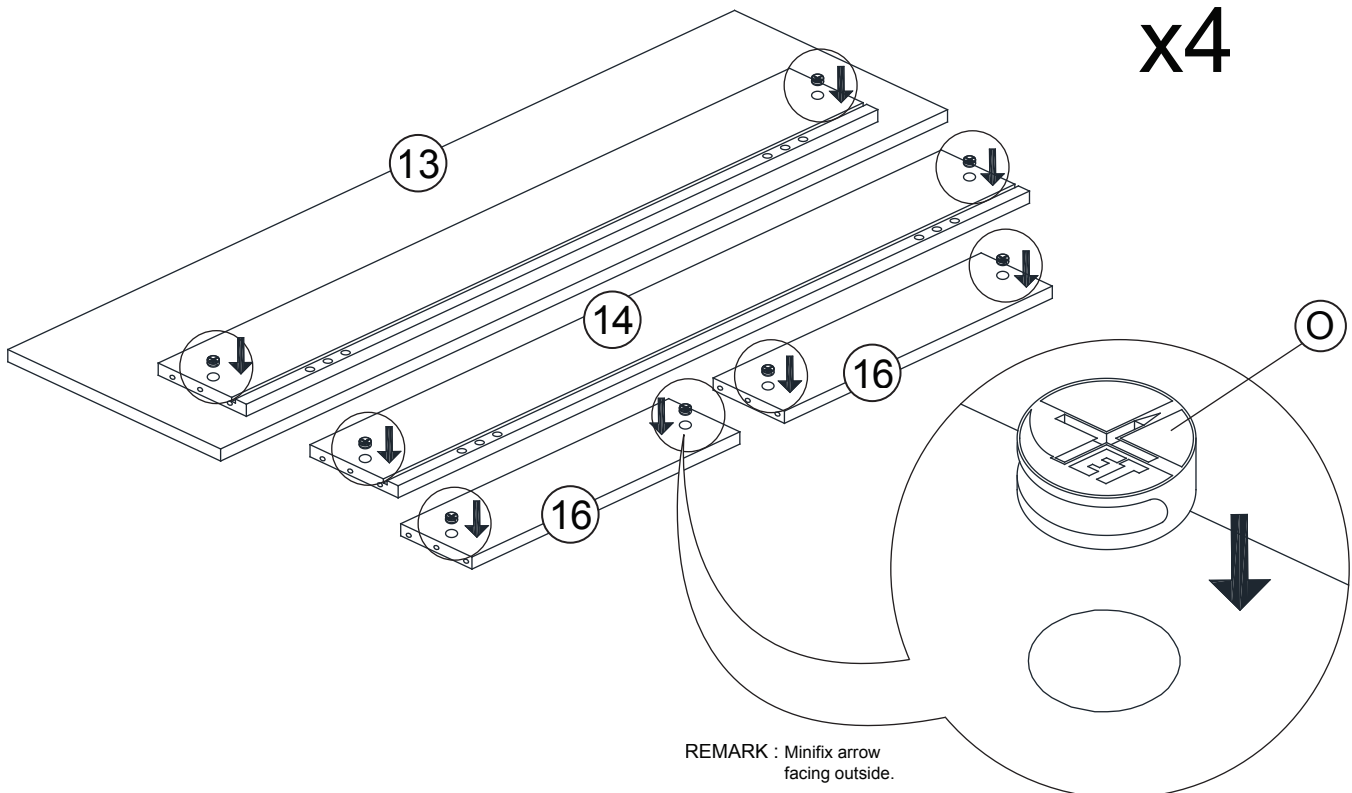

80113-311/321/331/341/511/521/531/541 ASSEMBLY INSTRUCTION

STEP 11

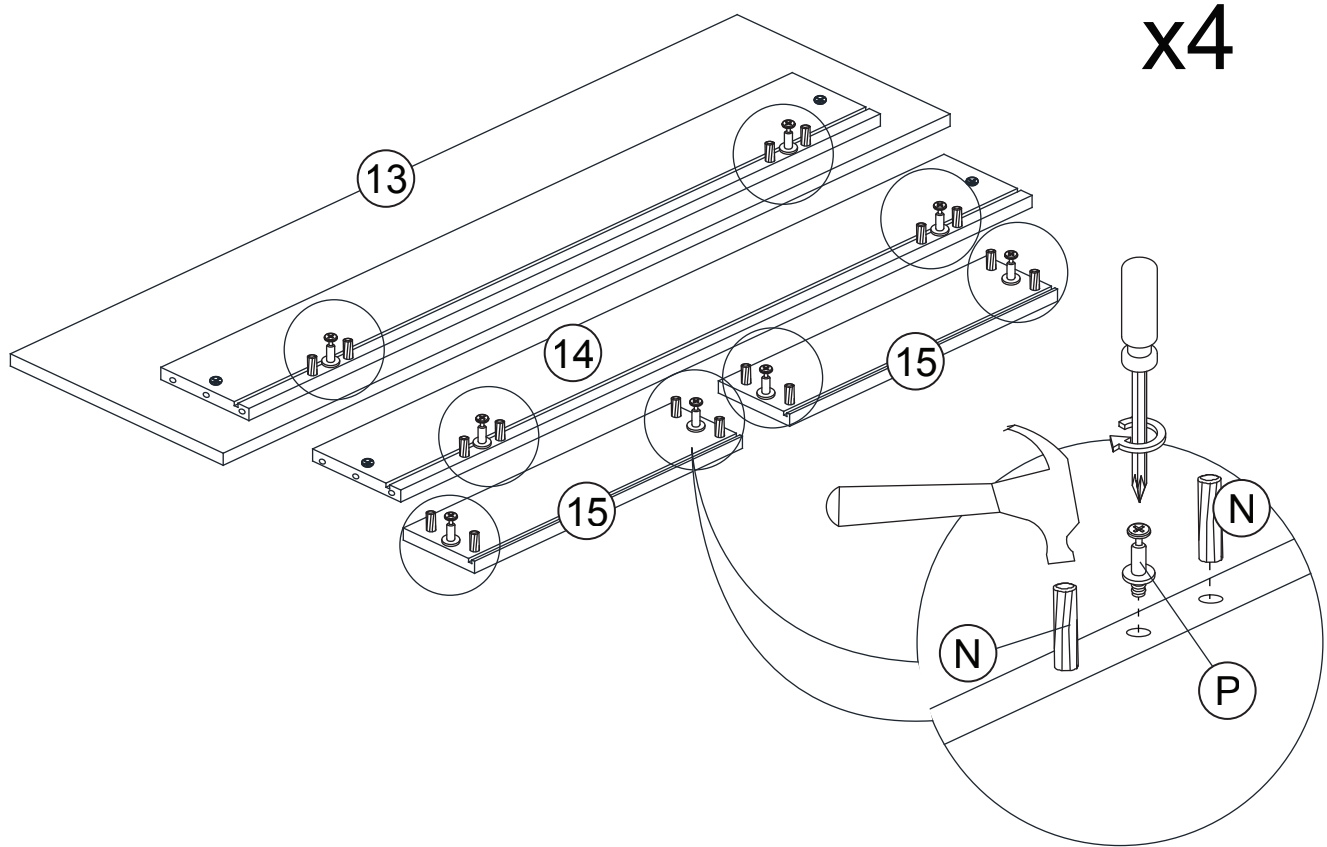

STEP 12

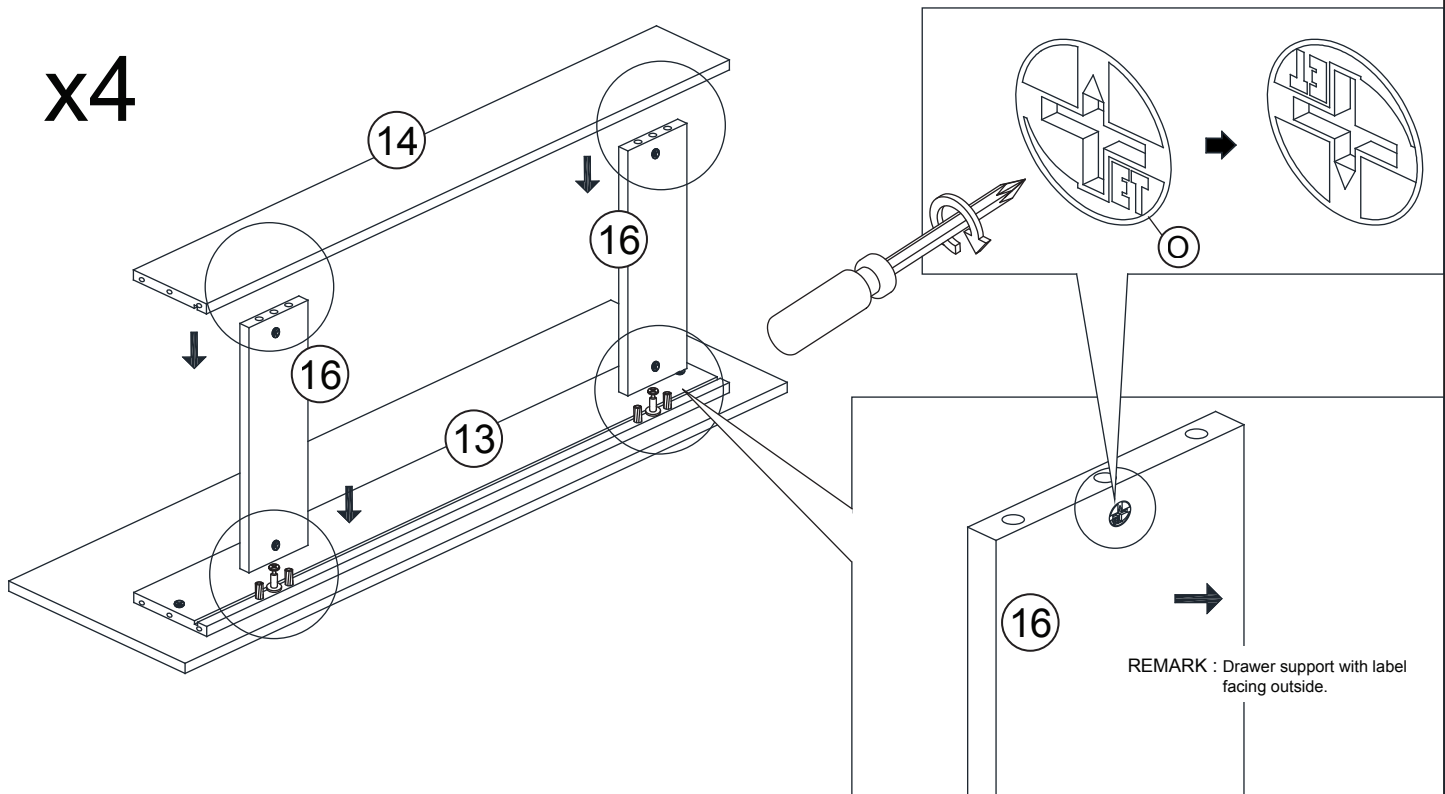

80113-311/321/331/341/511/521/531/541 ASSEMBLY INSTRUCTION

STEP 13

x4

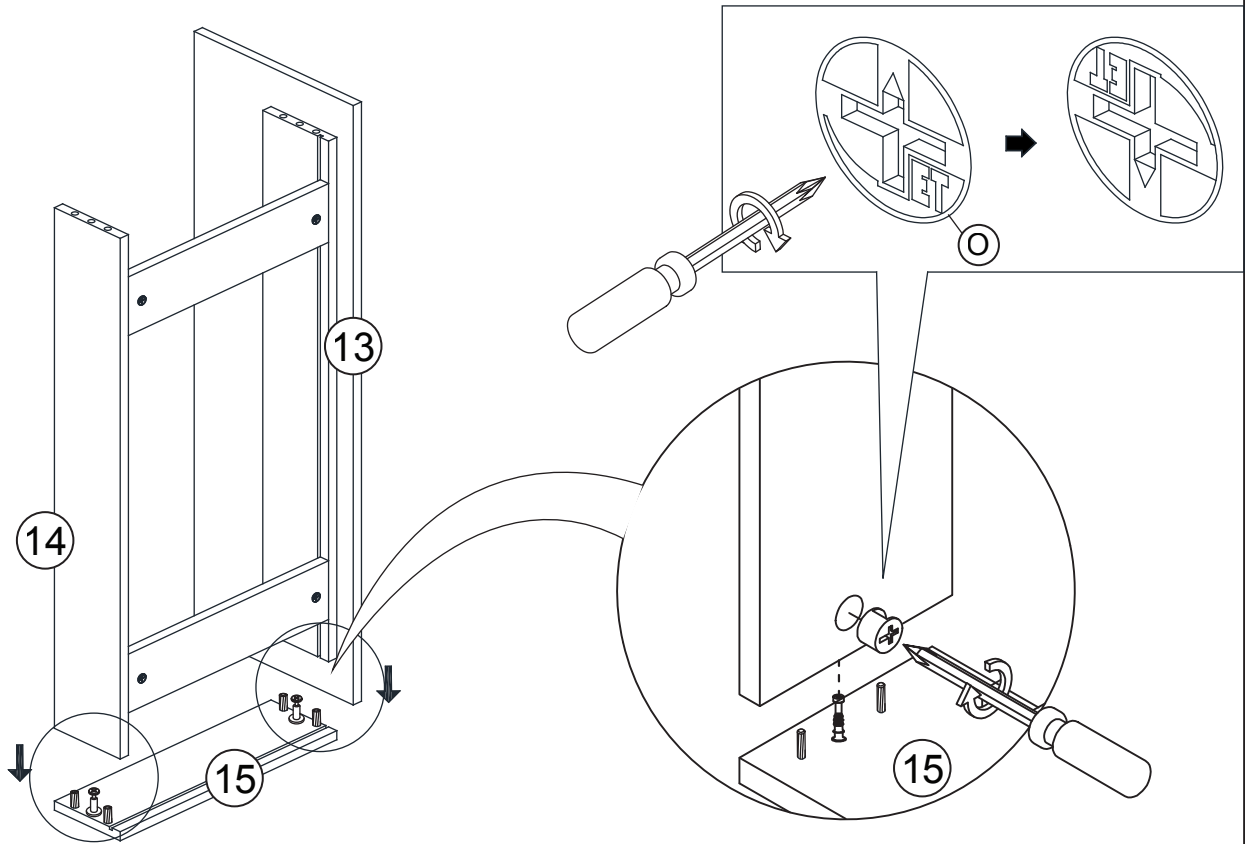

STEP 14

x4

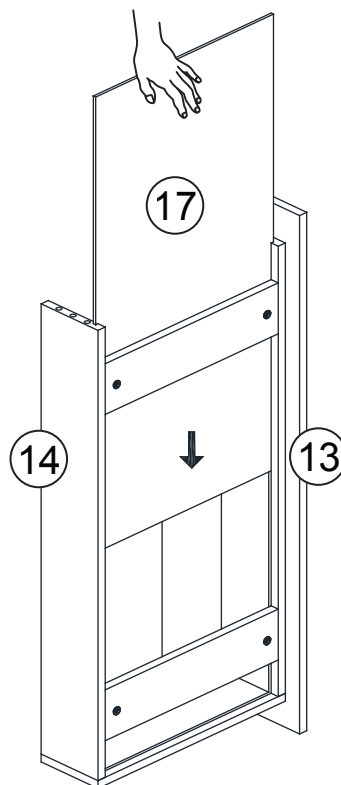

80113-311/321/331/341/511/521/531/541 ASSEMBLY INSTRUCTION

STEP 15

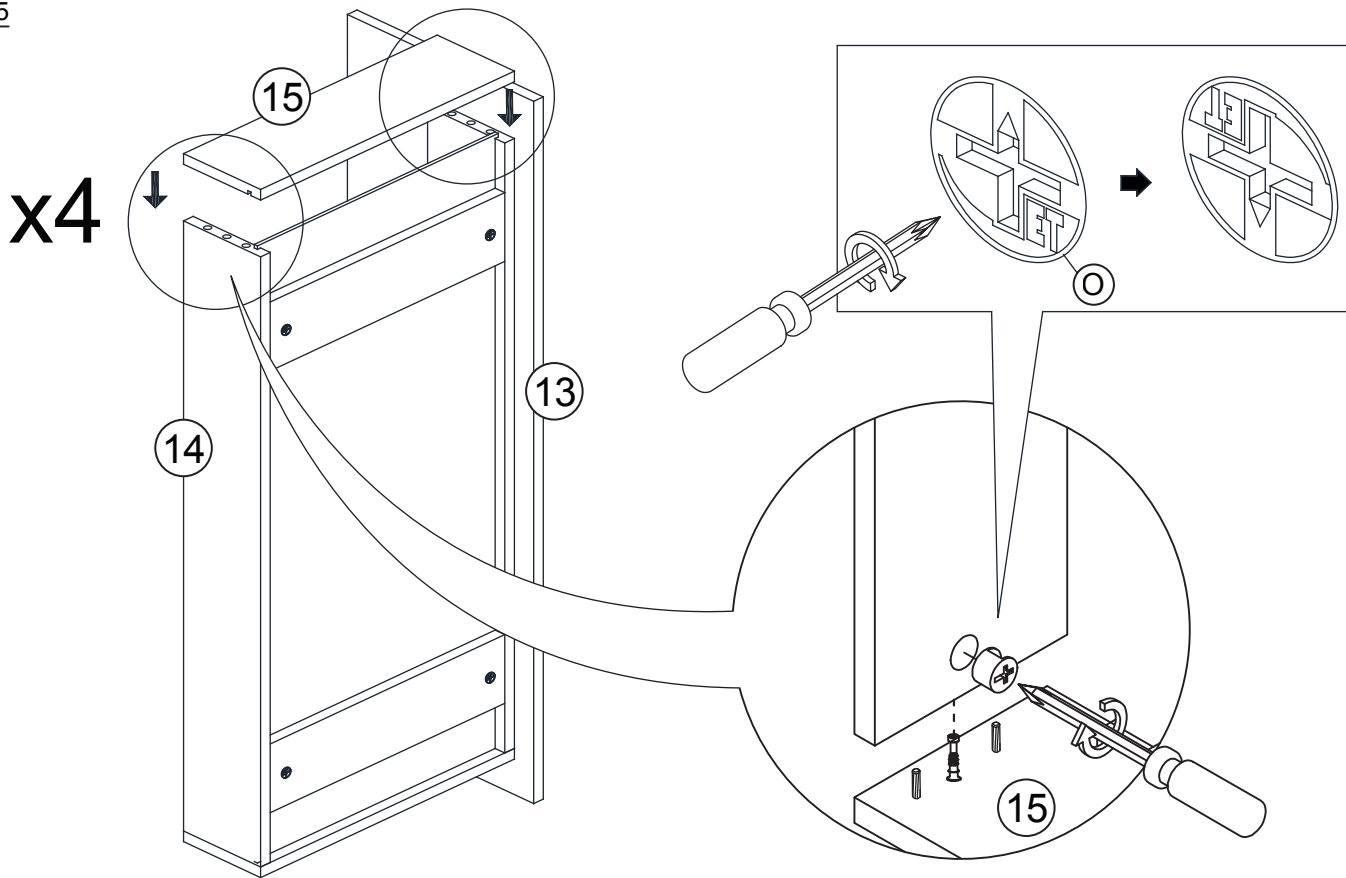

STEP 16

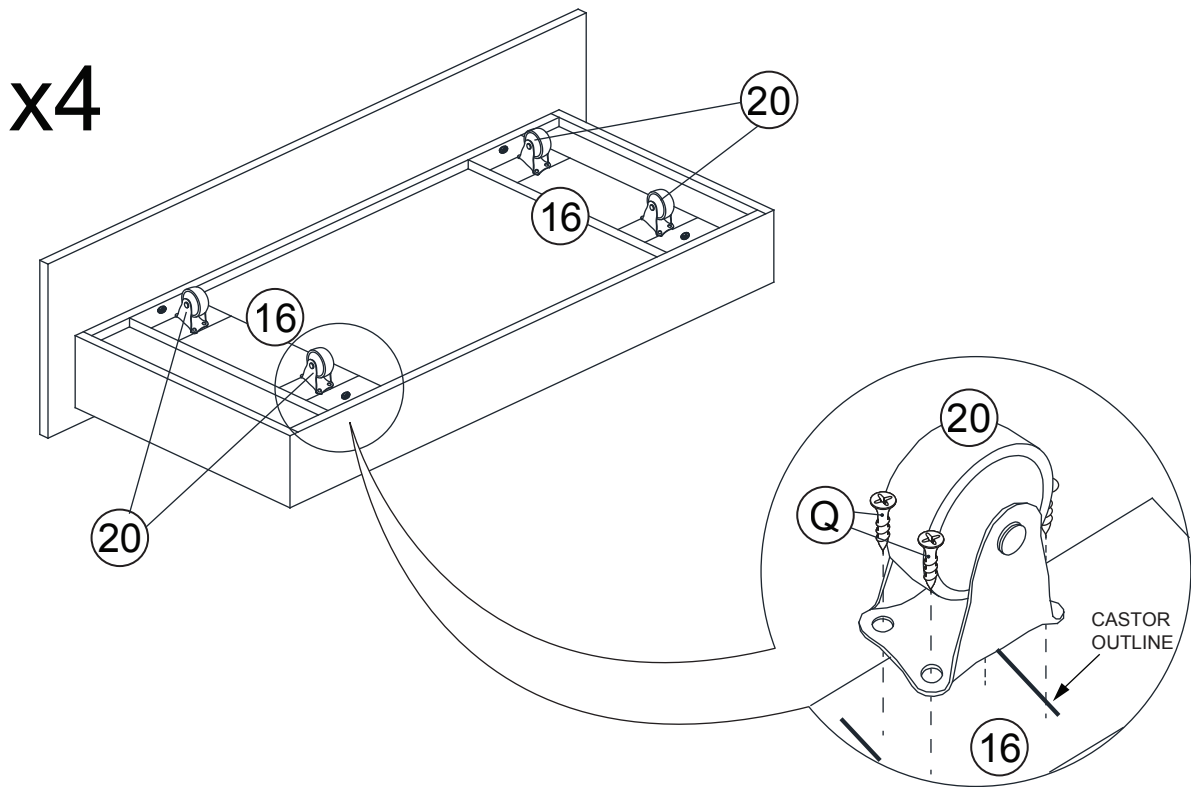

80113-311/321/331/341/511/521/531/541 ASSEMBLY INSTRUCTION

STEP 17

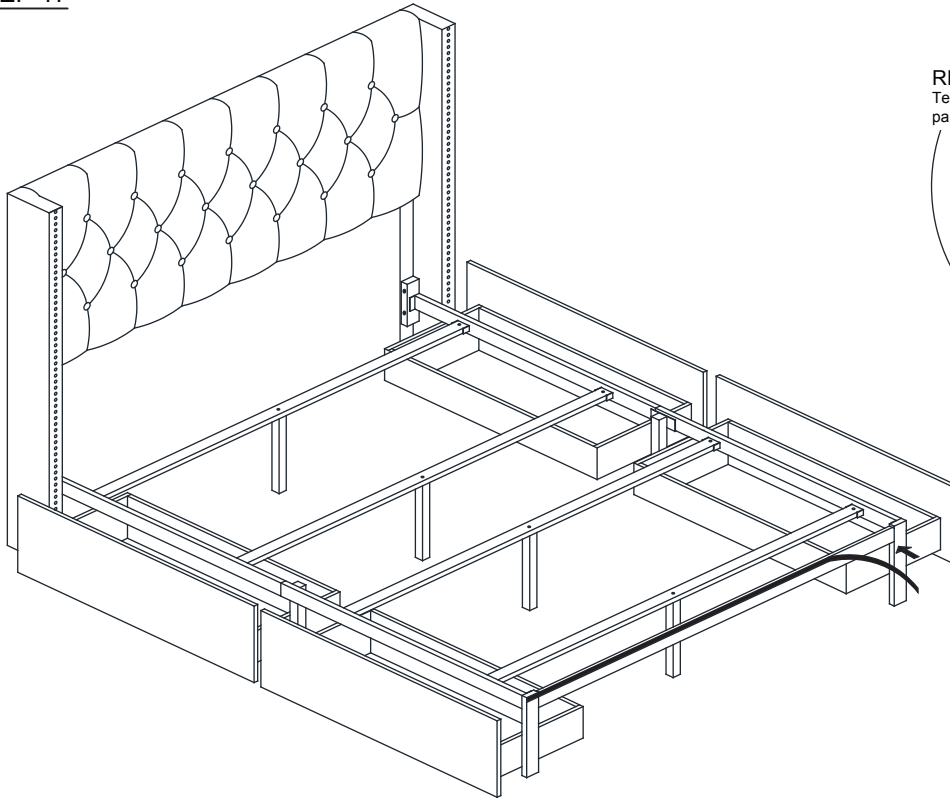

REMARK:
Tear off the white isolation
paper on the back

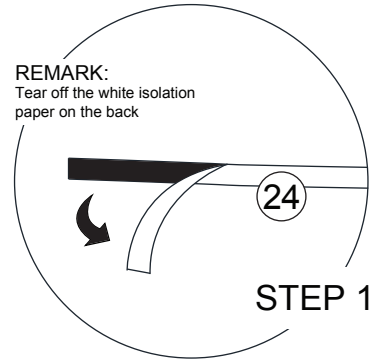

STEP 17.1

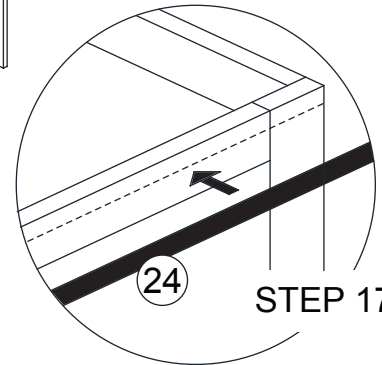

STEP 17.2

STEP 18

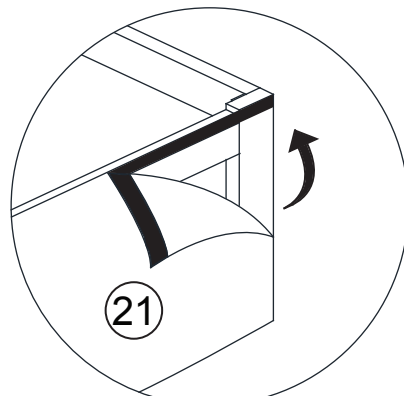
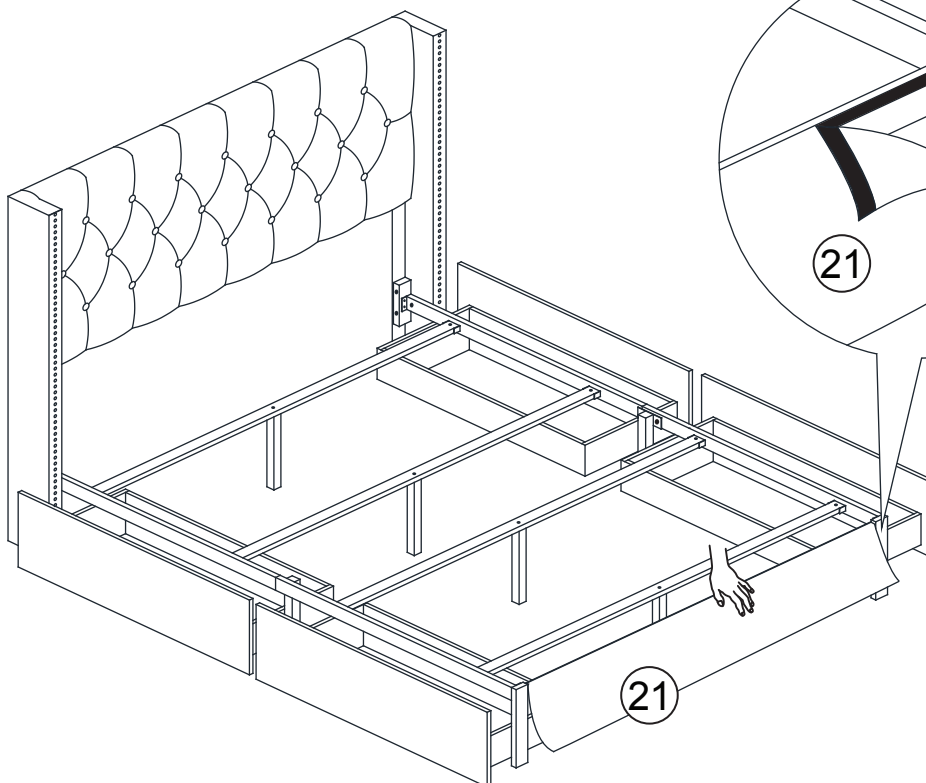

21

80113-311/321/331/341/511/521/531/541 ASSEMBLY INSTRUCTION

STEP 19

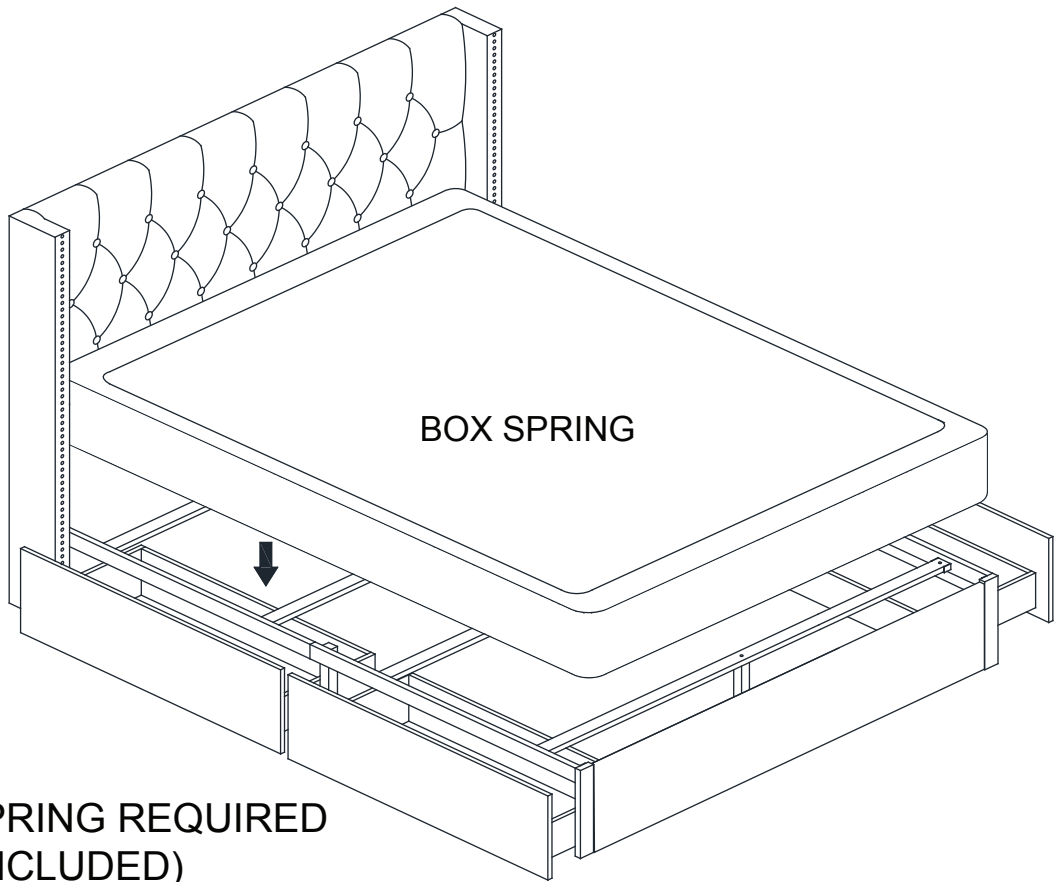

**BOX SPRING REQUIRED
(NOT INCLUDED)**

STEP 18

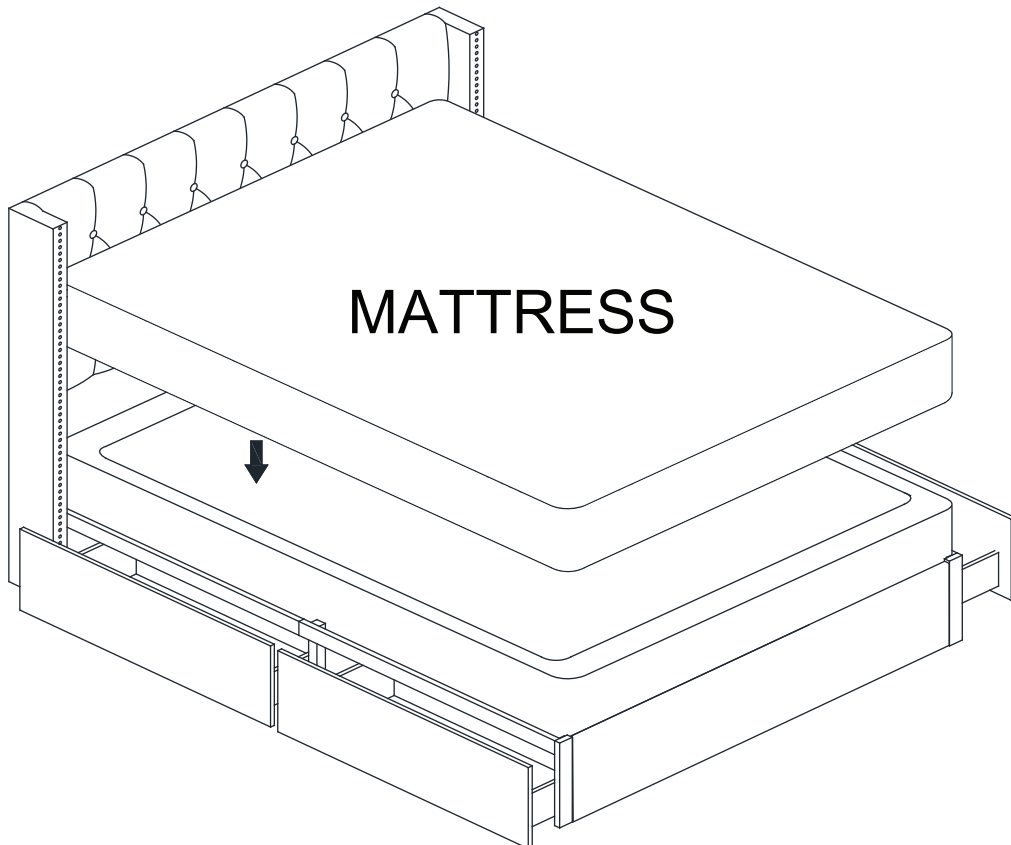

MATTRESS NOT INCLUDED

ASSEMBLY COMPLETED