

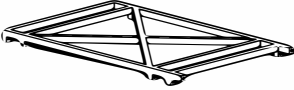



# ASSEMBLY INSTRUCTION

<b>A</b> Side Frame  2 pcs	<b>B</b> Shelf Frame  4 pcs	<b>C</b> Mirror 8T*828*457mm  2 pcs	<b>D</b> Castor  4 pcs
<b>E</b> Bolt 1" * 1" 4 * 2  16 pcs	<b>F</b> Glass Support  12 pcs	<b>G</b> Allen Wrench 4mm  1 pc	

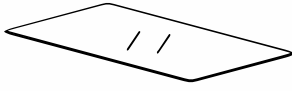
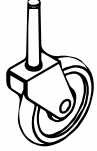
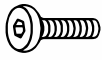

This page lists all the contents included in the box. Please take the time to identify the hardware as well as the individual components to this product. As you unpack and prepare for assembly, place the contents on a carpeted or padded area to protect them from damage.

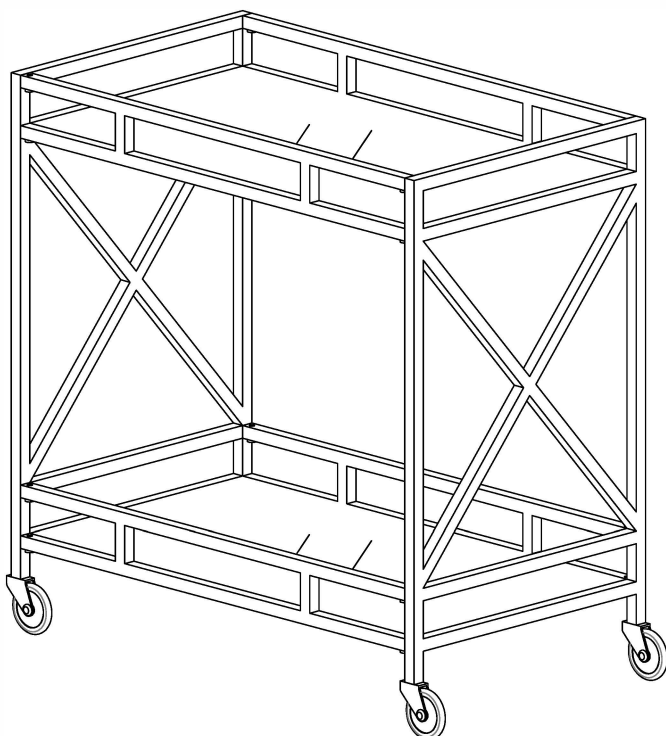
1

Insert the castor (D) into the tube end hole of side frame (A) as shown in drawing.

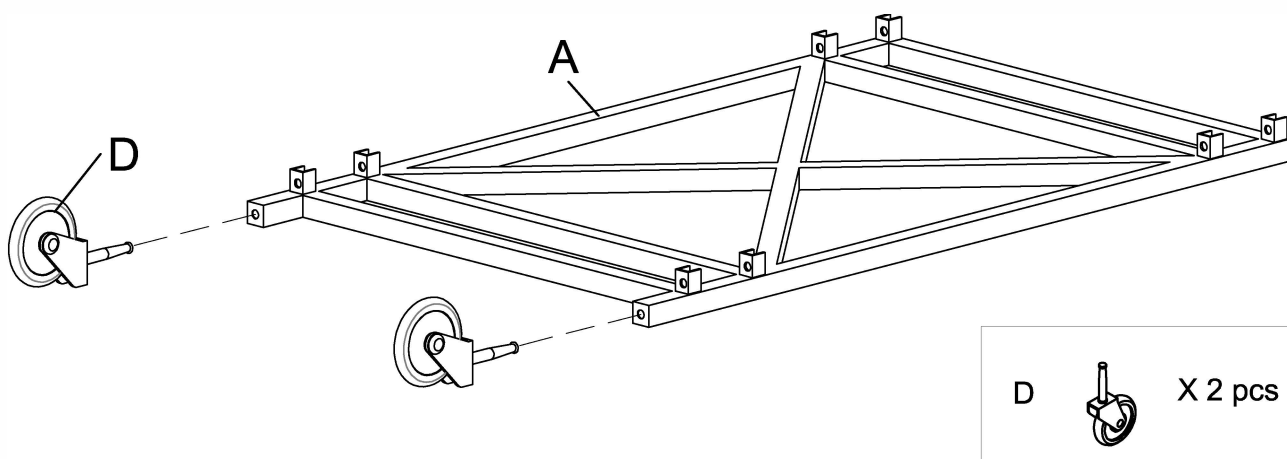

2

Assemble the shelf frame (B) and side frame (A) with bolt (E) and tighten with allen wrench (G).

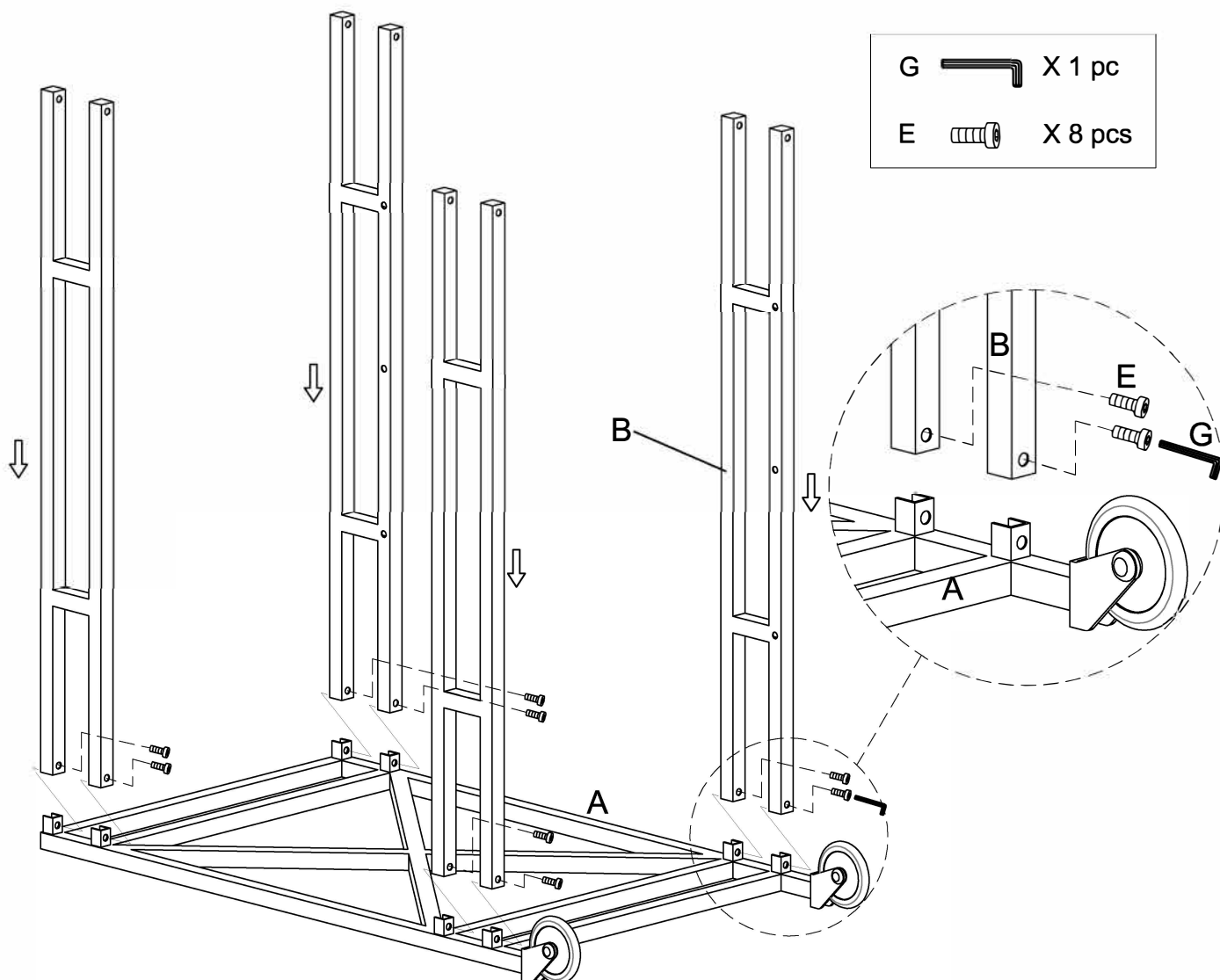

**3**

Assemble the other side frame (A) on top of the sub-assembly shelf frame (B) with bolt (E) and again tighten with allen wrench (G).

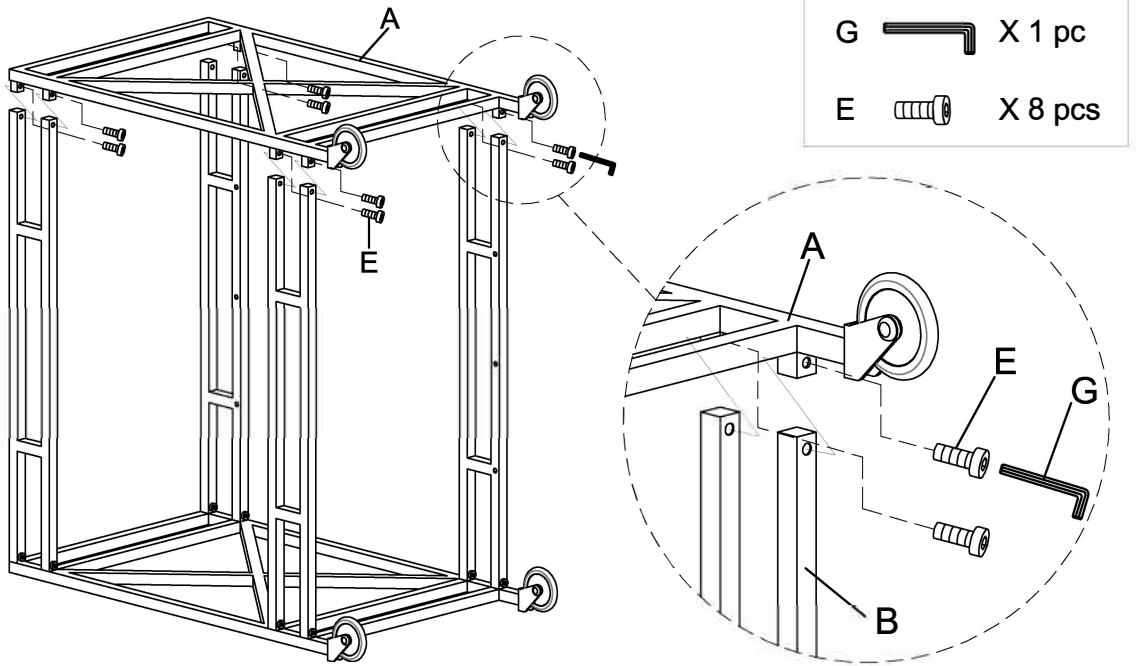
**4**

Upright the bar cart as shown in the drawing and put glass support (F) in place of top and bottom shelf frame. Then put mirror (C) on top and bottom shelf.

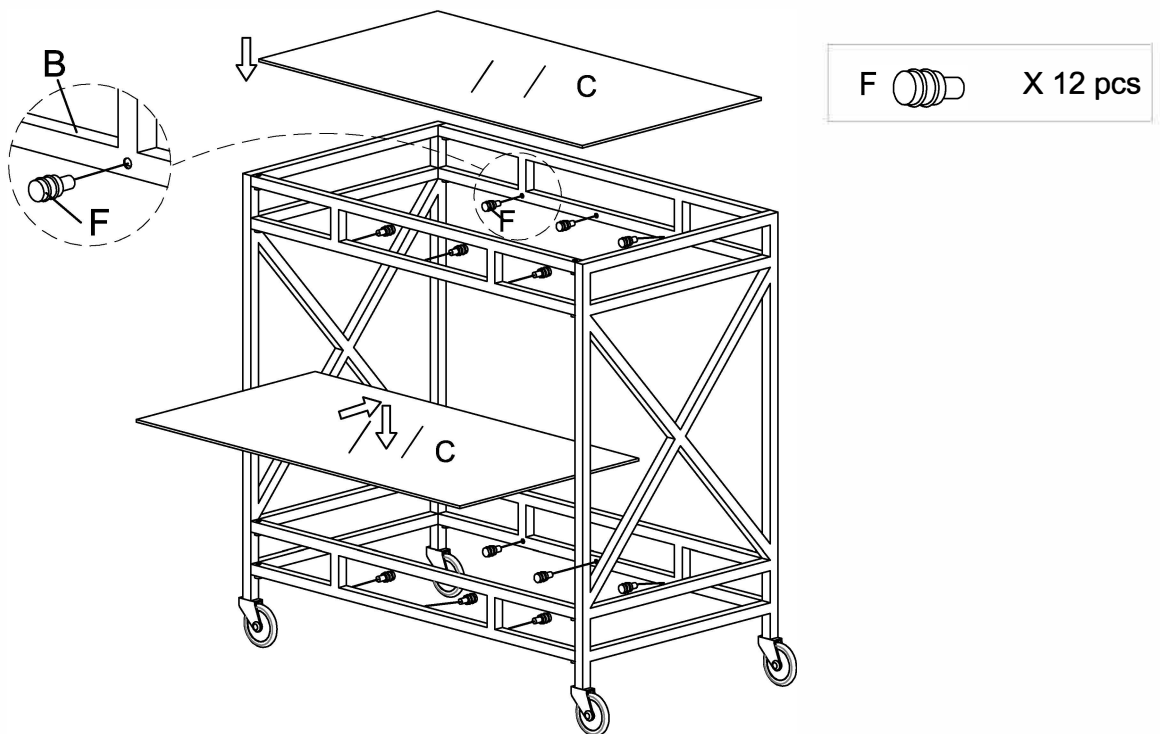

#### Cleaning & Care

Treat surface with care. Surface is resistant to scratches but is not scratch resistant. Clean surfaces with a dry or damp soft cloth. Do not use abrasive cleaners. Hardware may loosen over time. Periodically check that all connections are tight.