

# ASSEMBLY INSTRUCTION

## QUEEN ARCHED HEADBOARD KING ARCHED HEADBOARD

**A** Headboard Panel

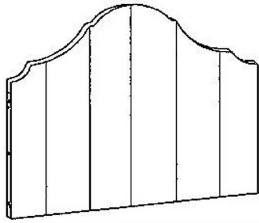

1 pc

**B** Headboard Leg with marking Left & Right



2 pcs

**C** JCBC Bolt  
M6 X 50mm



6 pcs

**D** Flat Washer  
M8x 16mm



6 pcs

**E** Spring Washer  
5/16"



6 pcs

**F** Allen Key  
M4



1 pc

**G** Wooden Dowel  
08 x 30mm



4 pcs

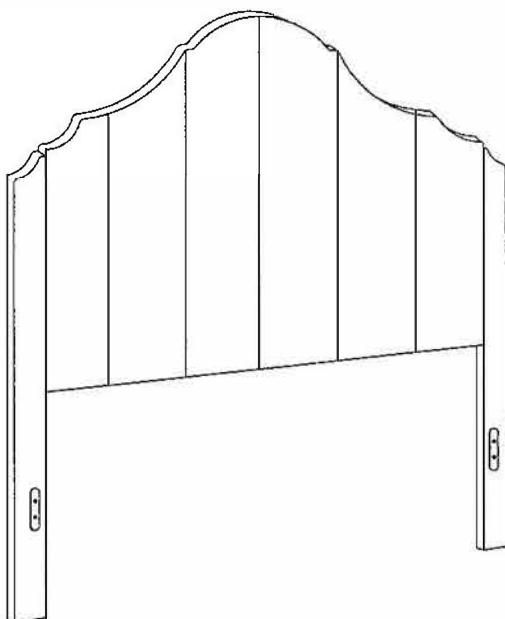

This page lists all the contents included in the box. Please take the time to identify the hardware as well as the individual components to this product. As you unpack and prepare for assembly, place the contents on a carpeted or padded area to protect them from damage.

**IMPORTANT NOTE:**

1. Do not tighten all screws/ bolts until all completely assemble.
2. Keep all hardware parts out of reach of children.

**1** Insert Wooden Dowel (G) to the left & right holes at the Headboard Panel (A).

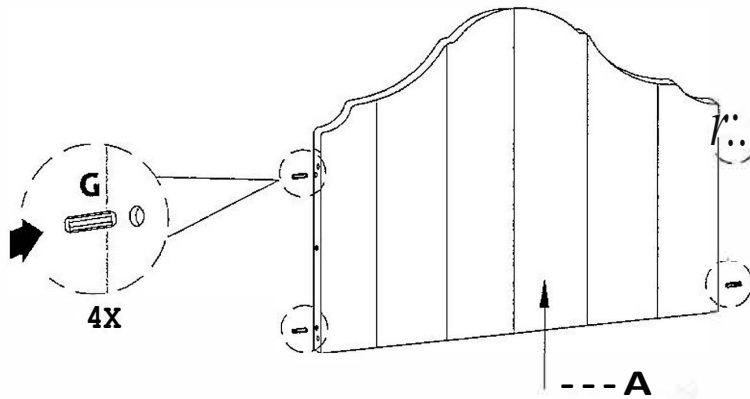

**2** Turn the Headboard Panel (A) upside down and place it on a piece of cloth to prevent from scratching. Attached Headboard Leg (B) to the Headboard Panel (A). Insert JCBC Bolt (C), Spring Washer (E) and Flat Washer (D) to the holes and tighten using Allen Key (F).

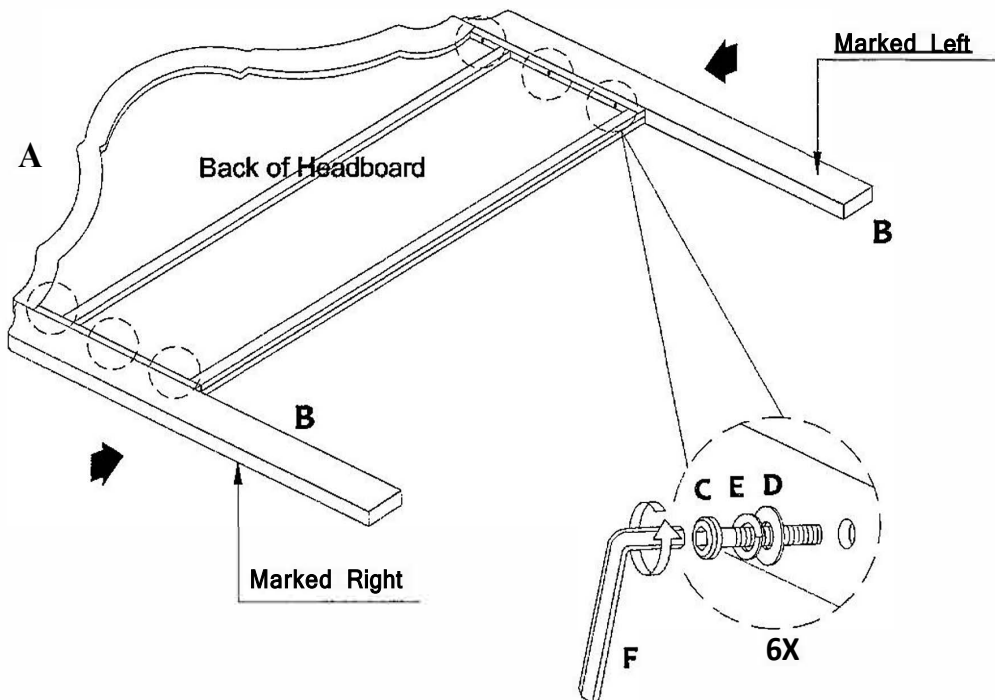

#### CLEANING&. CARE

Treat surface with care. Surface is resistant to scratches but is not scratches resistant. Clean surface with a dry or damp soft cloth. Do not use abrasive cleaners. Hardware may loosen over time. Periodically check that all connections are tight