

ASSEMBLY INSTRUCTIONS

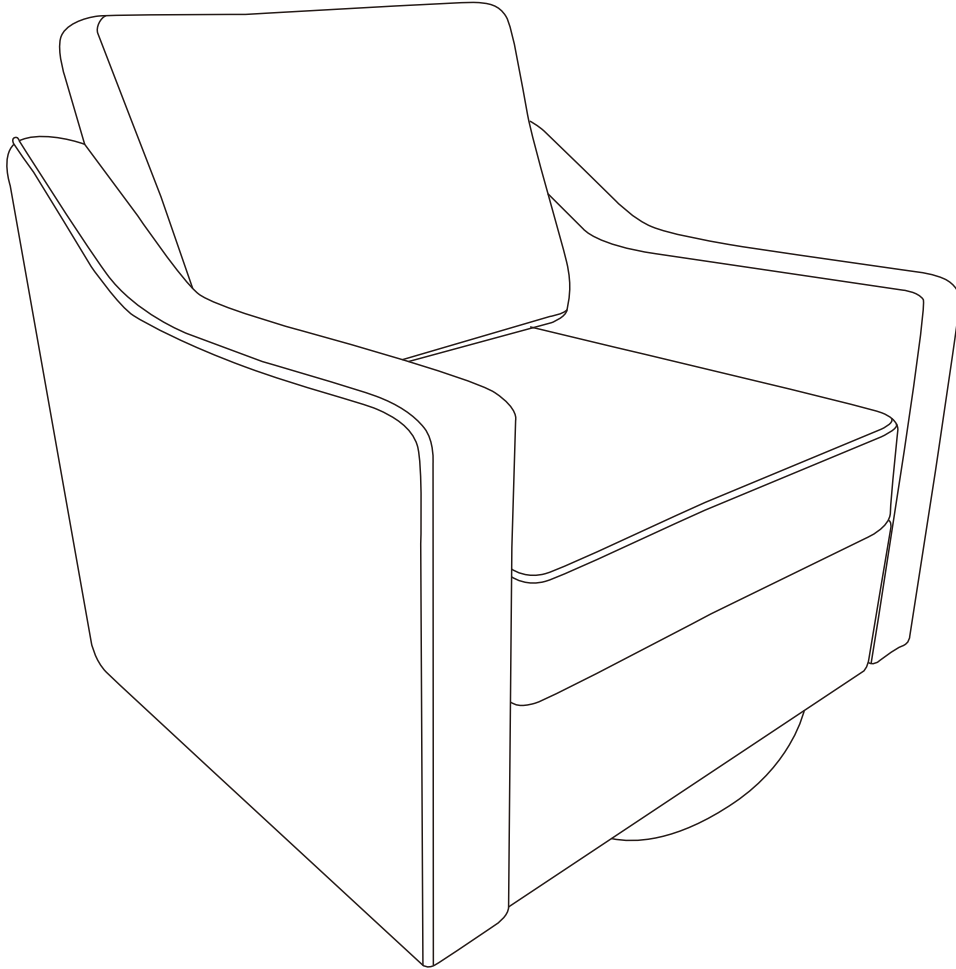

Important Notice:

Pls check all parts are included before assembly.

Questions and After-Sales Service:

For any queries, or if something's damaged, please feel free to contact our official support via purchase platform for prompt and warm assistance.

Thanks for your cooperation. Take care and stay safe~

Parts List

Ax1

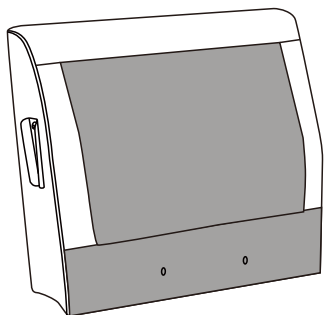

Bx1

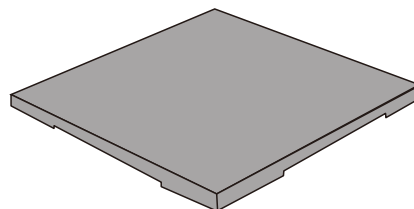

Cx1

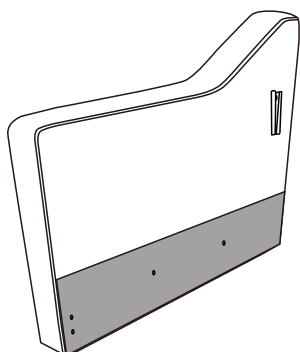

Dx1

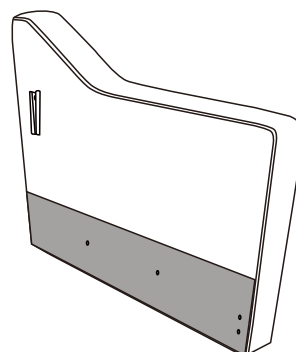

Ex1

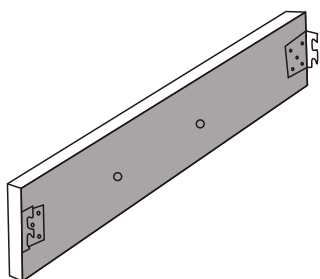

Fx4

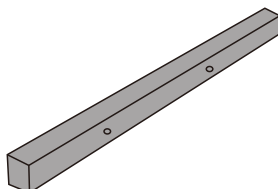

Gx1 (open last)

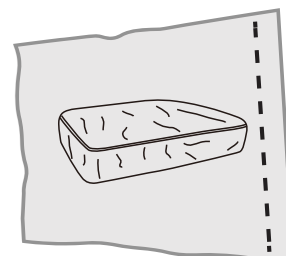

Hx1

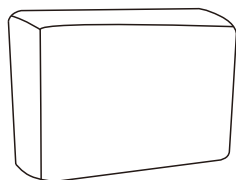

Ix1

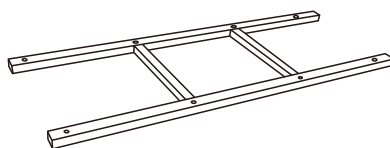

Jx1

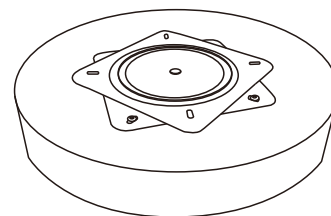

① x12+1

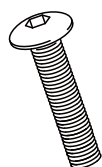

M6*45mm
Bolt

② x4+1

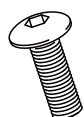

M6*20mm
Bolt

③ x4+1

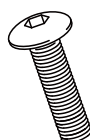

M6*35 mm
Bolt

④ x8+1



Washer

⑤ x1



Allen Key

Installation Steps

1

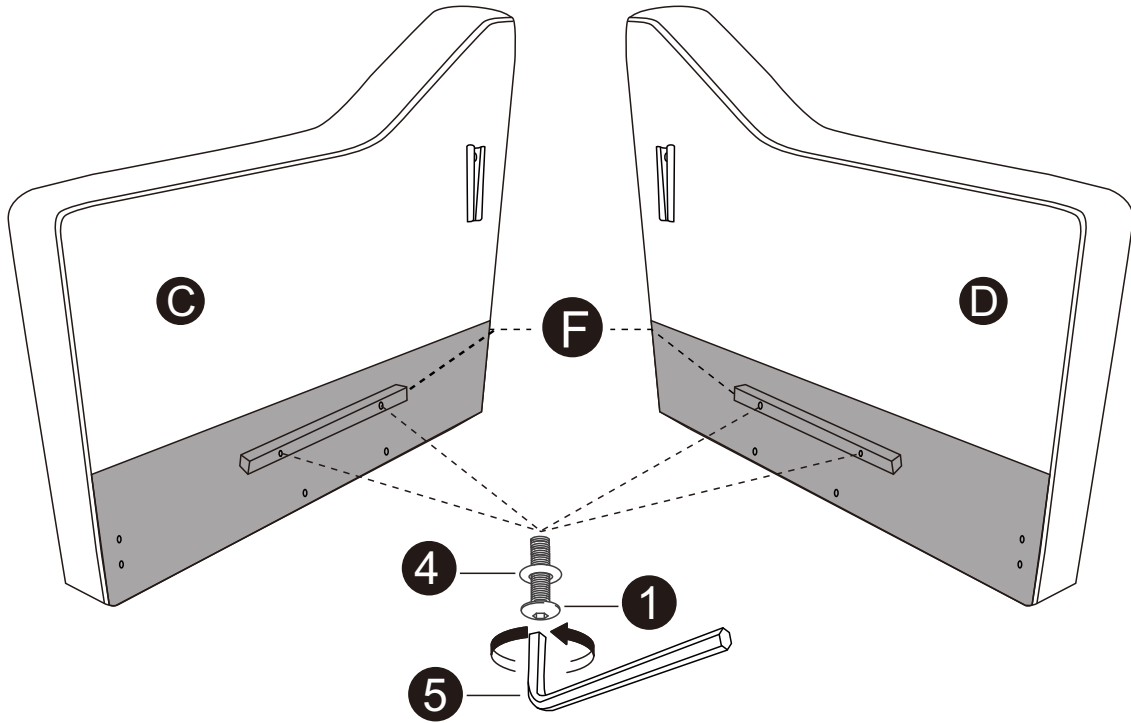

Attach the side rail bars (F) to the armrests (C,D) with bolts (1), washers (4) and allen key (5).

2

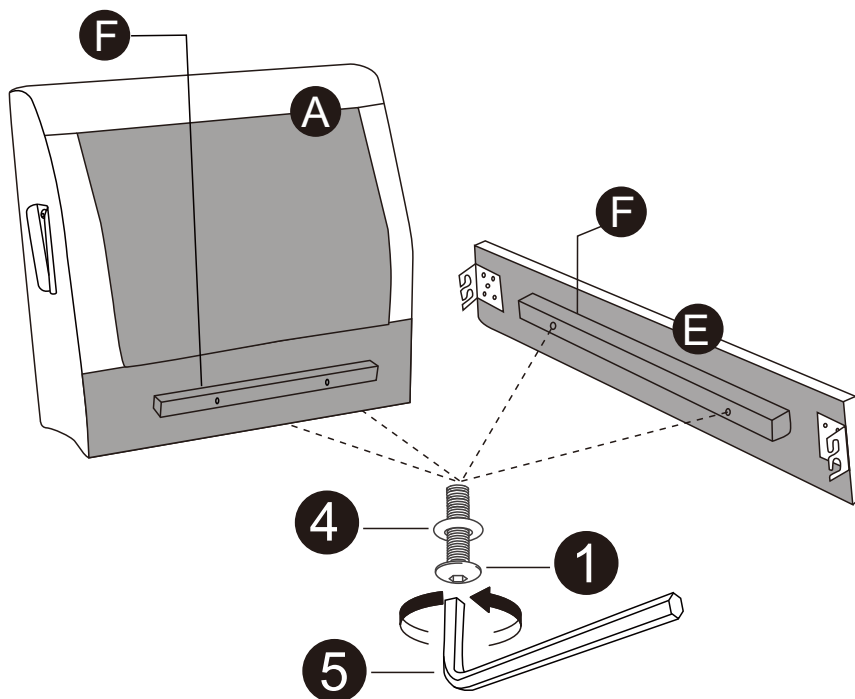

Attach the back and front rail bars (F) to the back frame (A) and front rail (E) with bolts (1), washers (4) and allen key (5).

3

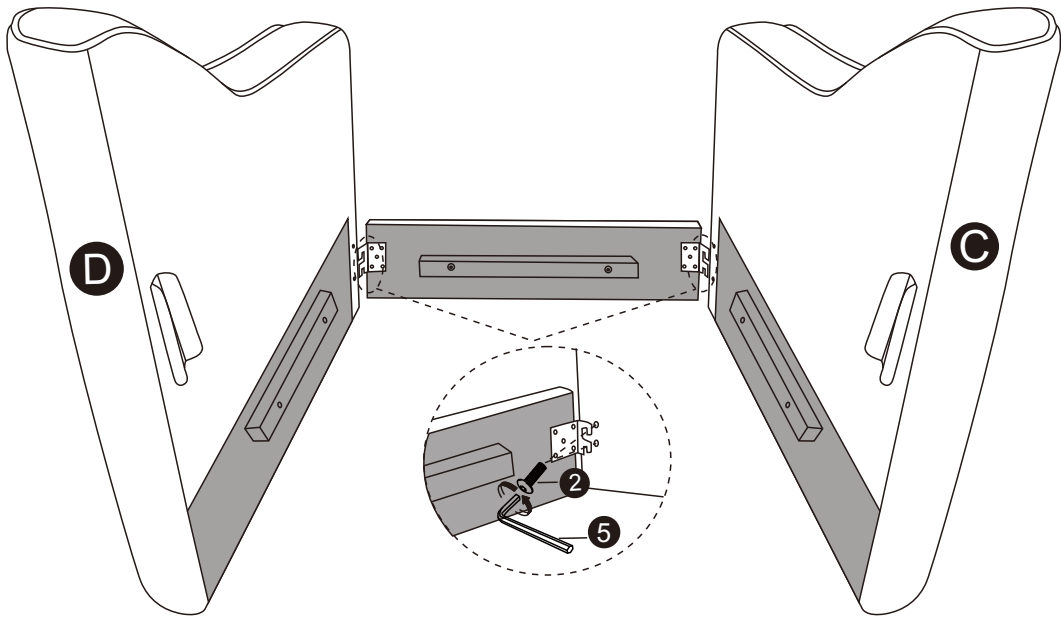

Attach front rail (E) to armrests (C,D) with bolts (2) and allen key (5). Tighten the bolts (2) 70% so that you can adjust slightly during the process of assembly.

4

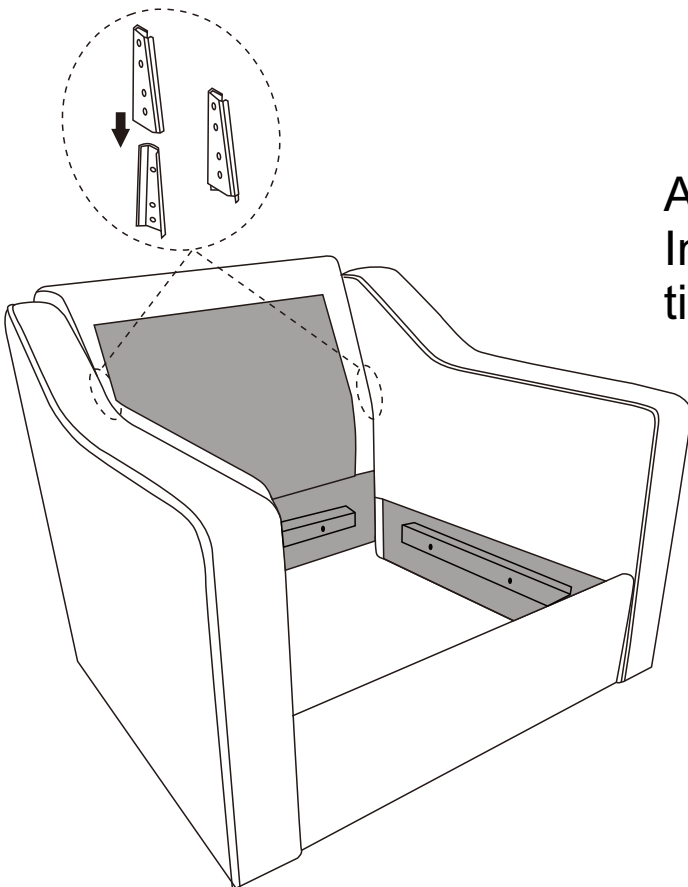

Attach backrest (A) to armrest, Insert both connectors at the same time, push hard to connect fully.

5

Attach part (I) to armrests (C,D) with bolts (3) and allen key (5). Tighten the bolts (3) 70% so that you can adjust slightly during the process of assembly. After all screws are through the holes, tighten all.

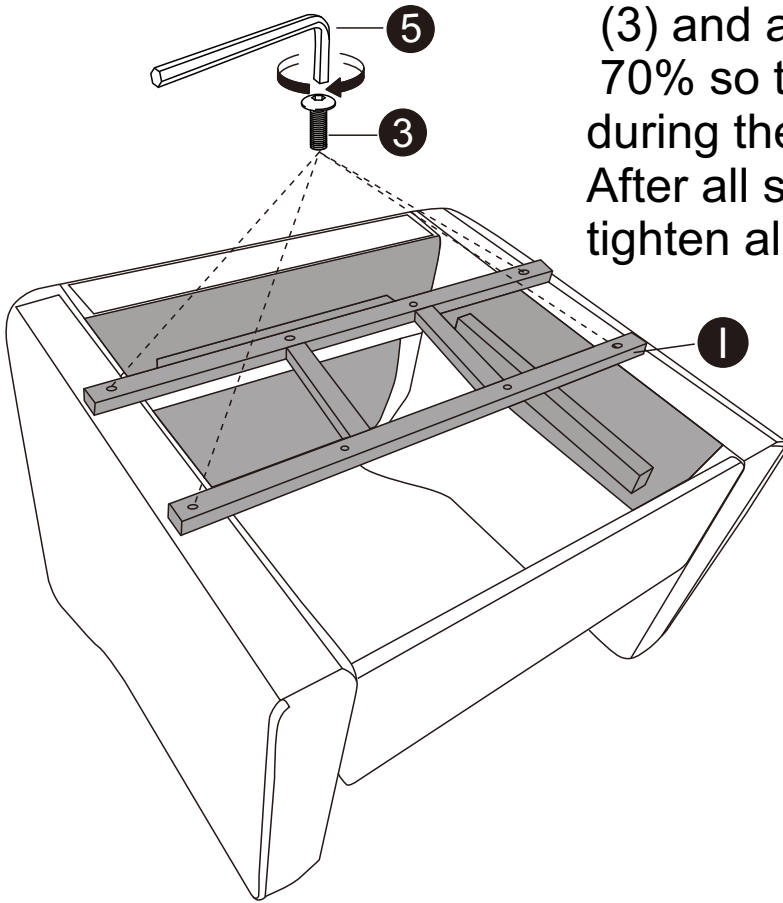

6

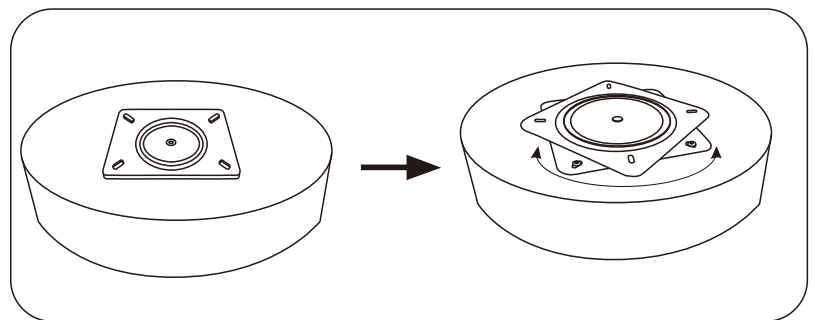

Rotate the swivel on rotary base (J) 45° as shown.

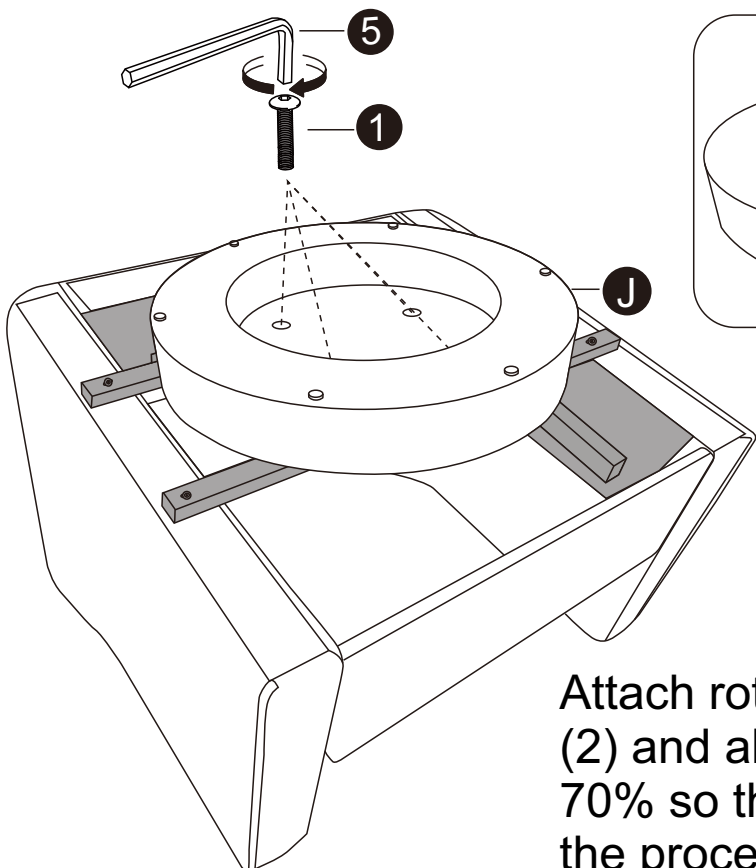

Attach rotary base (J) to part (I) with bolts (2) and allen key (5). Tighten the bolts (2) 70% so that you can adjust slightly during the process of assembly.

7

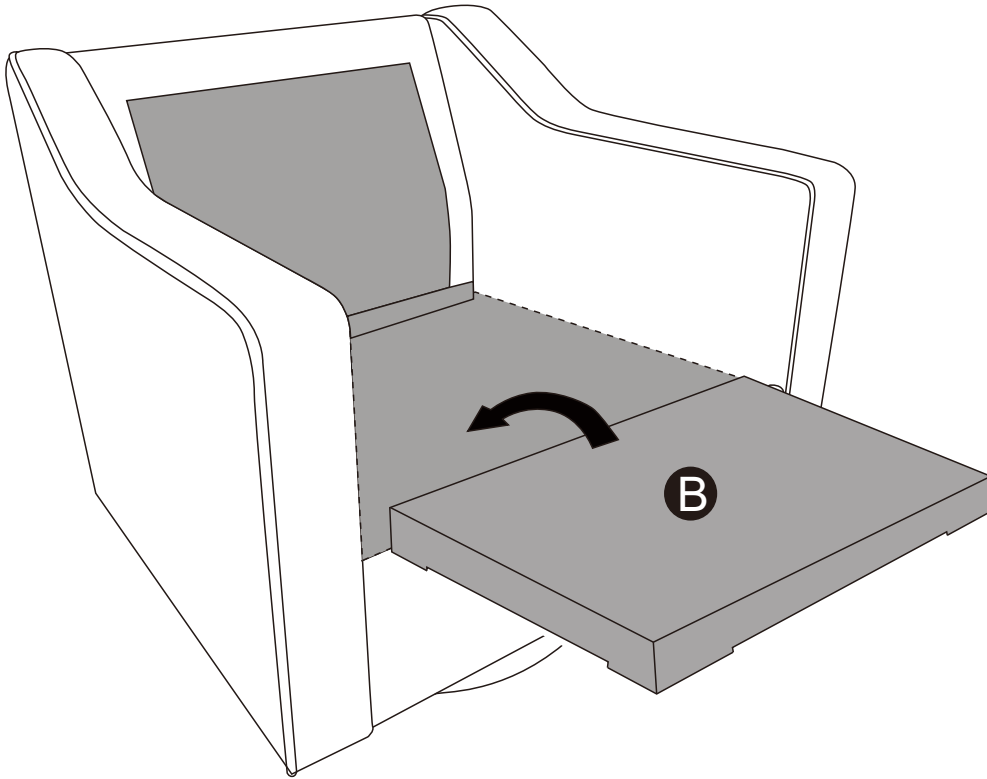

Place seat frame (B) onto the rails.

8

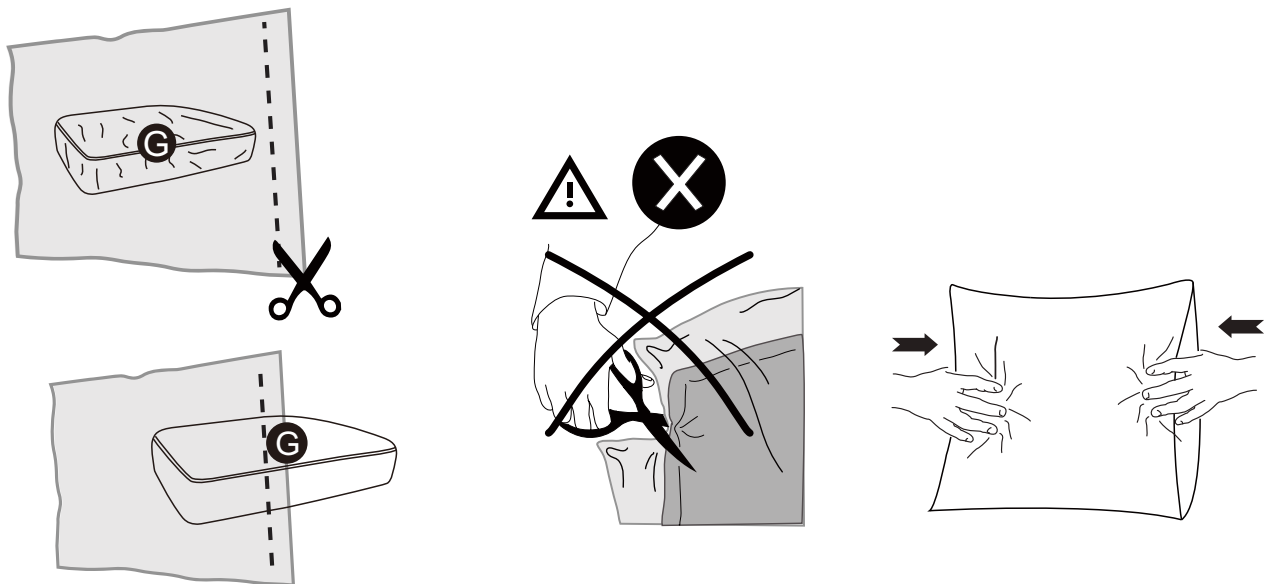

Please be careful not to cut the cushion when removing it. For the first time, need to be patted and rubbed from all angles for about 5 minutes, and can be completely restored to shape, soft and comfortable after 24 hours of placement.

9

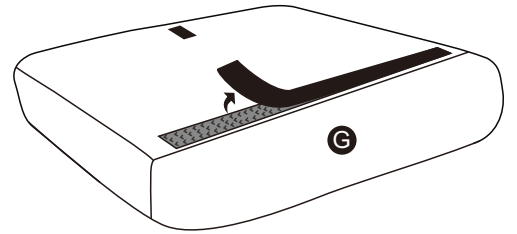
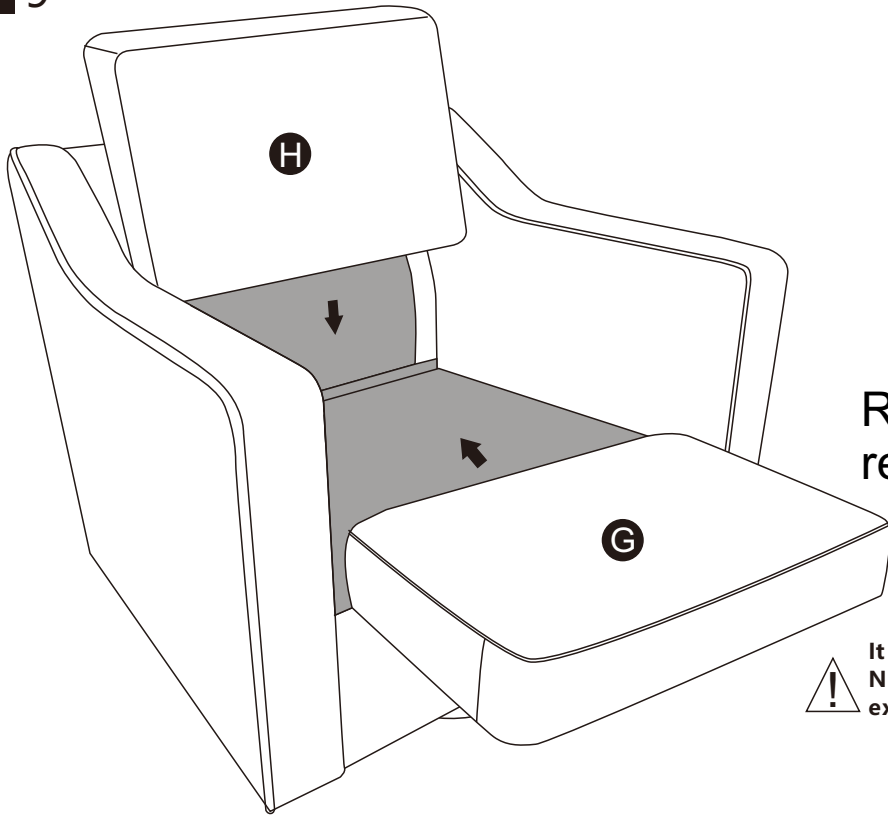

Remove the straps on the reverse side of the cushion.



It will take a while for the cushions to expand. Normally it will take up to around 24 hours to expand to its full size.

Place seat cushion (G) onto seat frame, then place back cushion (H) onto backrest.

10

