

DIMENSIONS

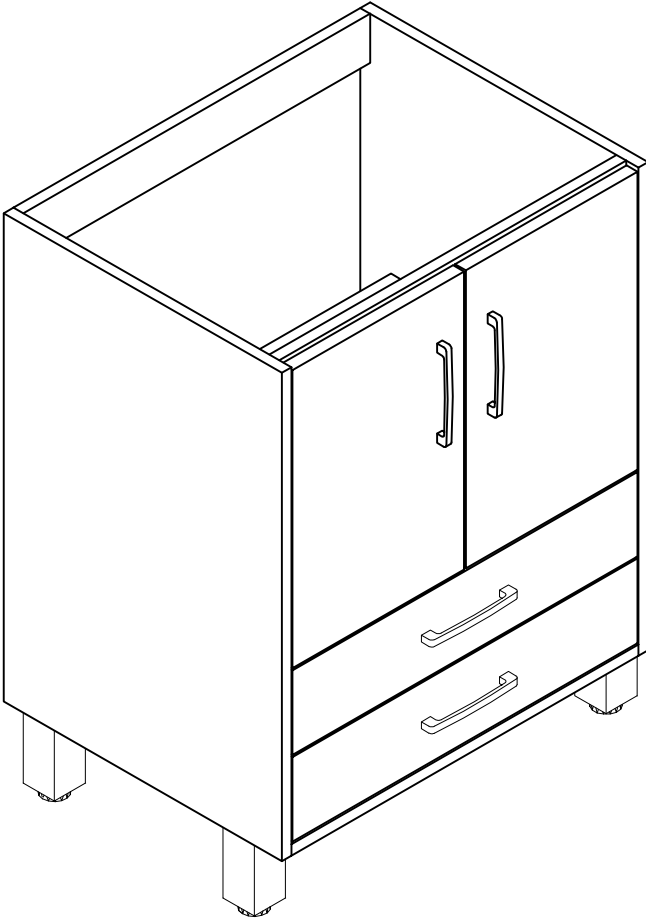

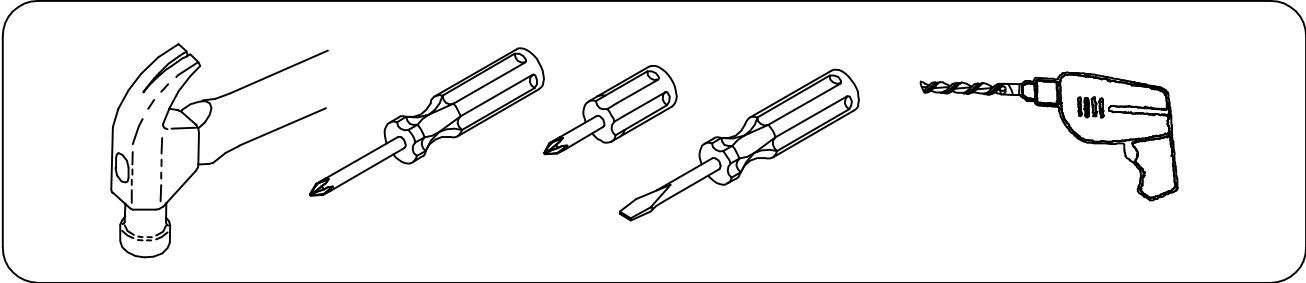





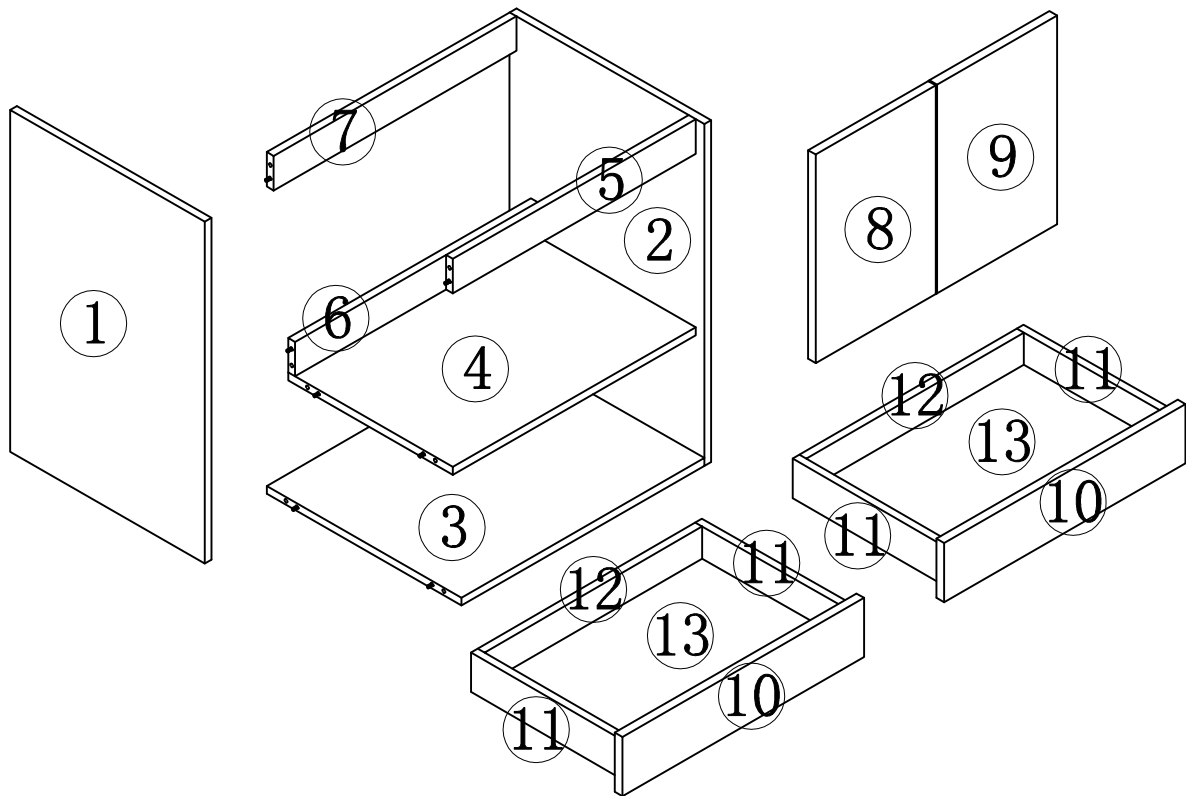

















YOU MAY NEED (NOT SUPPLY)





ASSEMBLY DIAGRAM



PARTS LIST					
PARTS LIST					
NO	DESCRIPTION	QTY	NO	DESCRIPTION	QTY
①	Left side panel 	1	⑧	Left door panel 	1
②	Right side panel 	1	⑨	Right door panel 	1
③	Bottom panel 	1	⑩	drawer panel 	2
④	laminate 	1	⑪	drawer side panel 	4
⑤	front pull-up 	1	⑫	drawer back panel 	2
⑥	rear drop down 	1	⑬	drawer bottom 	2
⑦	rear pull-up bar 	1			

PARTS LIST					
HARDWARE LIST					
NO	DESCRIPTION	QTY	NO	DESCRIPTION	QTY
A	Three-in-one eccentric wheel 	30	G	4*23mm screw 	8
B	Three-in-one connecting rod 	30	H	Door handle 	2
C	Three-in-one sticker 	30	I	Drawer handle 	2
D	8*40mm wood dowel pins 	14	J	Aluminum alloy leg 	4
E	Drawer slides 	4	K	Door hinge 	4
F	4*16mm screw 	60			
<p>CAUTION: Please confirm the parts list before installation</p>					

STEP 1

HARDWARE LIST	
Three-in-one connecting rod B  22PCS	

1. Put the three-in-one connecting rod in the 10mm hole of the following panels and tighten them with a cross screwdriver or an electric tool.

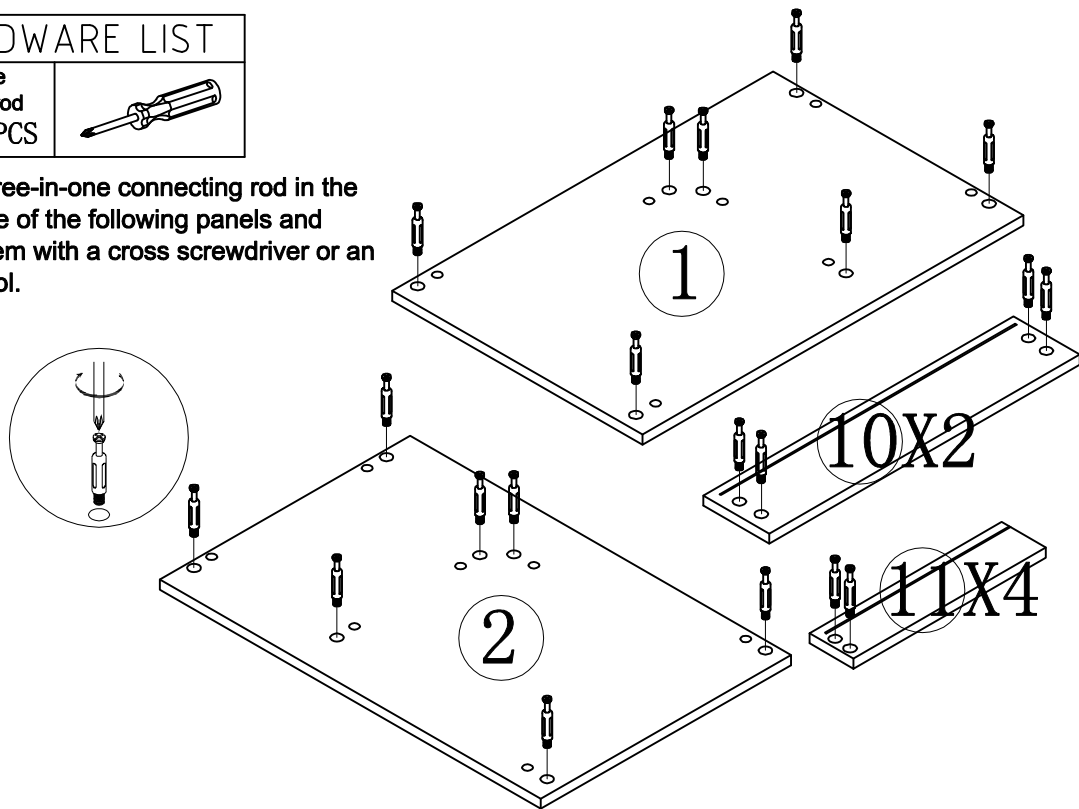

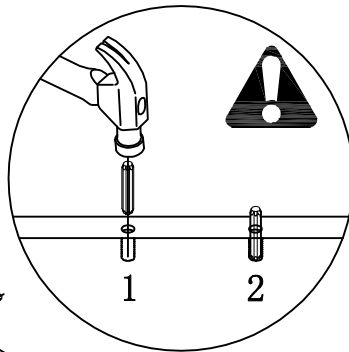

STEP 2



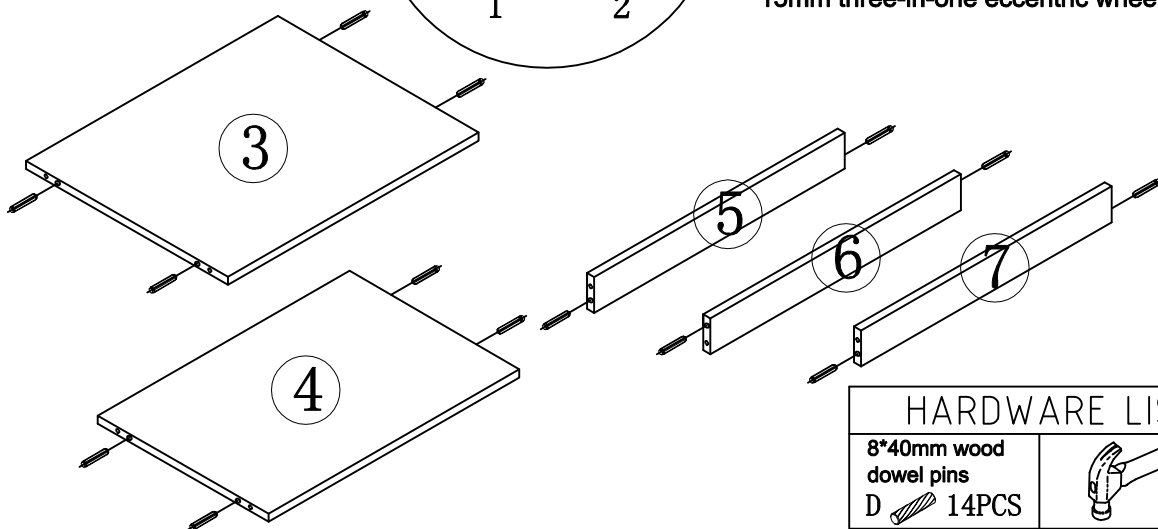

1. Strike the 08*40mm wood dowel pin into the 8mm hole of the above panels with an iron hammer. Please note that the hole of the three-in-one connecting rod should also be 8mm. The hole of the three-in-one connecting rod connects to the hole of 15mm three-in-one eccentric wheel.

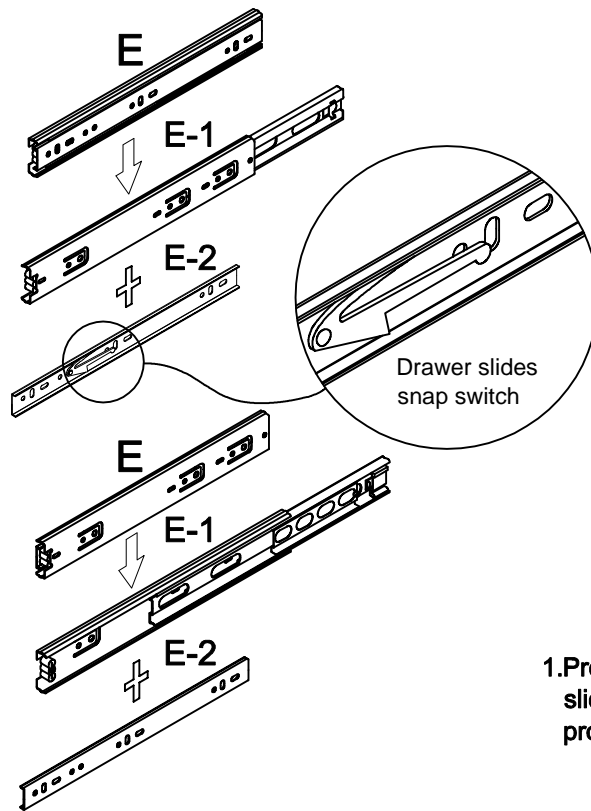

HARDWARE LIST	
8*40mm wood dowel pins D  14PCS	

STEP 3





HARDWARE LIST	
Drawer slides	
E  4PCS	

1. Press the slide snap switch, disassemble slide blocks and put them in a place properly for further use.

STEP 4

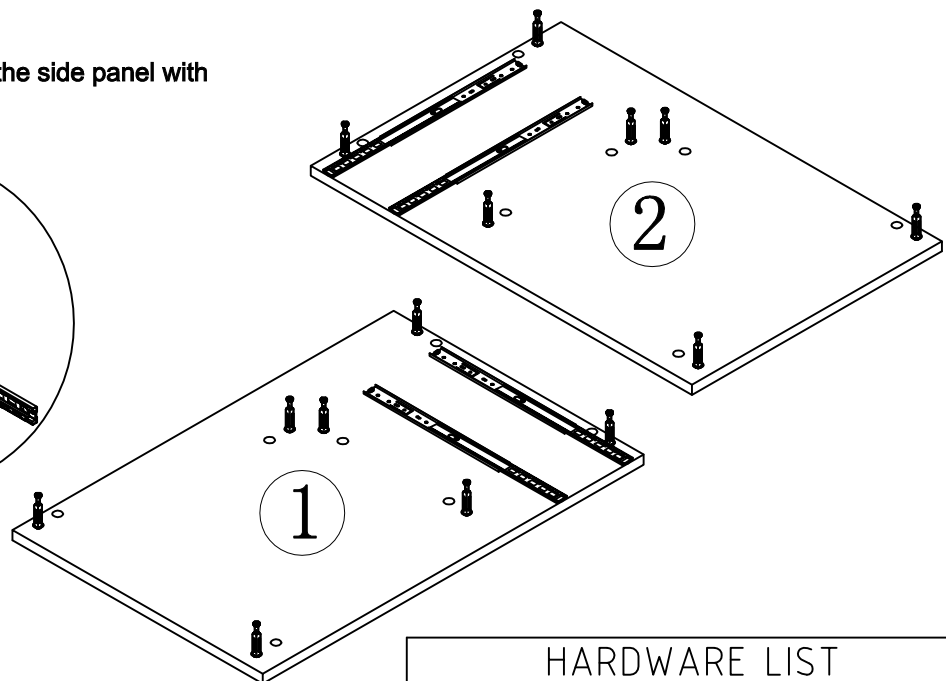
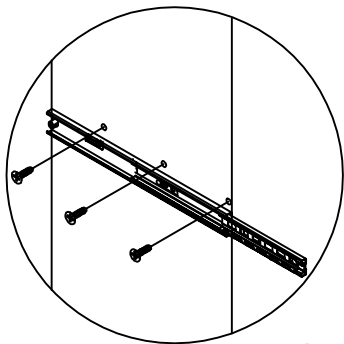
1. Fix the drawer slide to the side panel with 4*16mm screws.

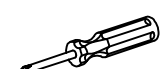

HARDWARE LIST		
4*16mm screw	Drawer slides	
F  12PCS	E-1  4PCS	

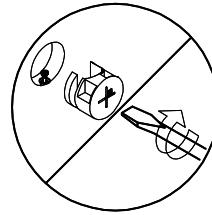
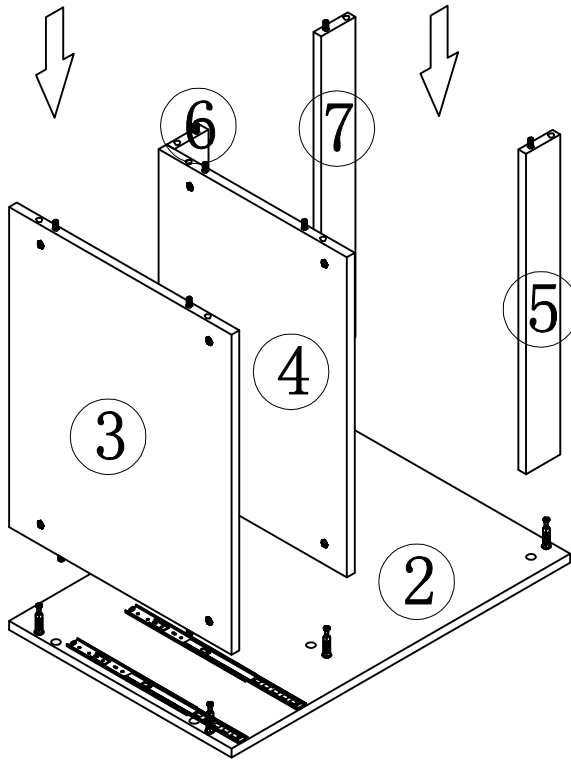

STEP 5

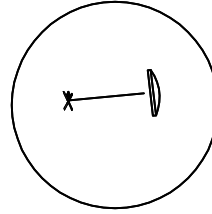

1. Connect No. 3-4-5-6-7 panel to No.2 panel tightly with the three-in-one eccentric wheel.



2. Cover the mounting hole of the eccentric wheel with a three-in-one sticker.

HARDWARE LIST		
Three-in-one eccentric wheel A  7PCS	Three-in-one sticker C  7PCS	

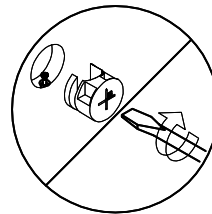
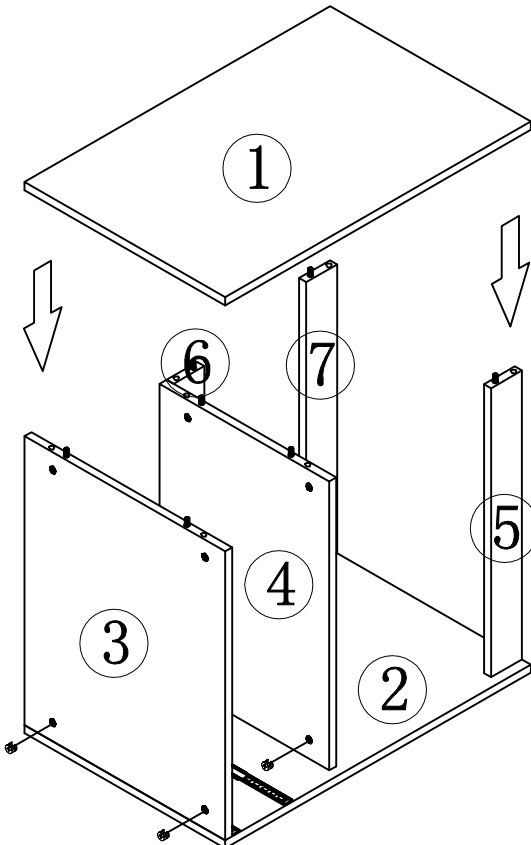

STEP 6

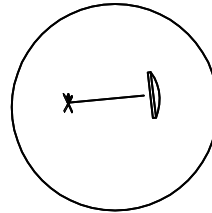

1. Connect No. 1 panel to No. 3-4-5-6-7 panel tightly with the three-in-one eccentric wheel.





2. Cover the mounting hole of the eccentric wheel with a three-in-one sticker.

HARDWARE LIST		
Three-in-one eccentric wheel A  7PCS	Three-in-one sticker C  7PCS	

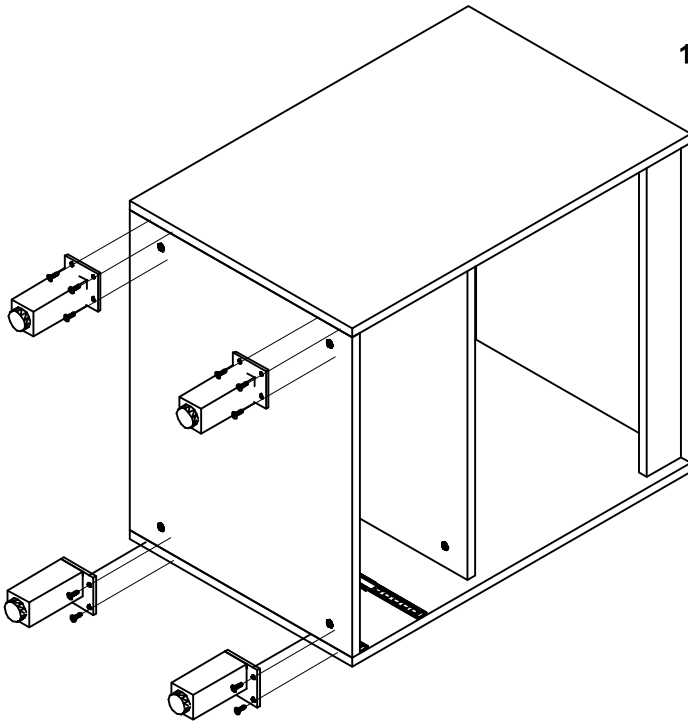
STEP 7

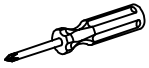

1. Fix feet of the cabinet with 4*16mm screws.

HARDWARE LIST		
4*16mm screw	Aluminum alloy leg	
F  12PCS	J  4PCS	

STEP 8

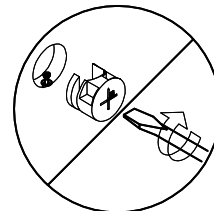
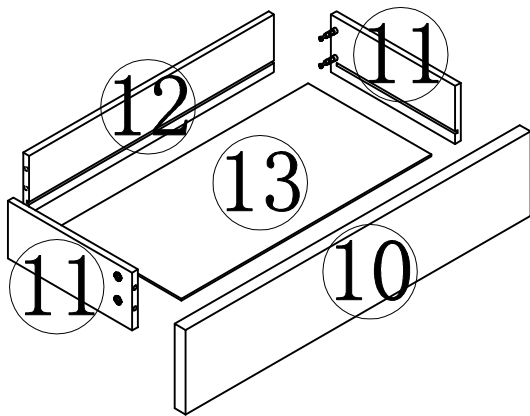

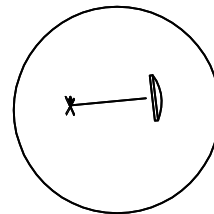

1. Install No. 10-11-12-13 panels with the three-in-one eccentric wheel tightly.

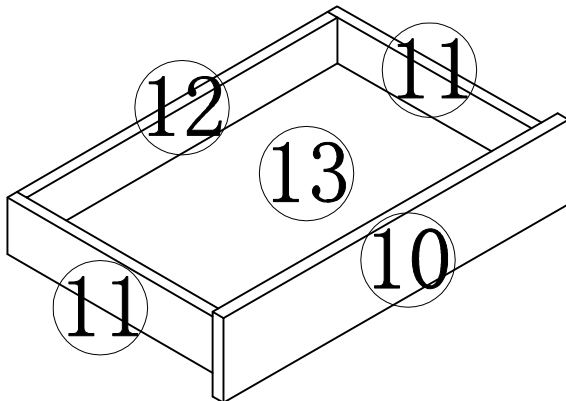

2. Cover the mounting hole of the eccentric wheel with a three-in-one sticker.



HARDWARE LIST		
Three-in-one eccentric wheel	Three-in-one sticker	
A  16PCS	C  16PCS	

STEP 9

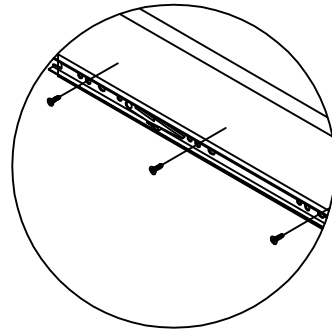
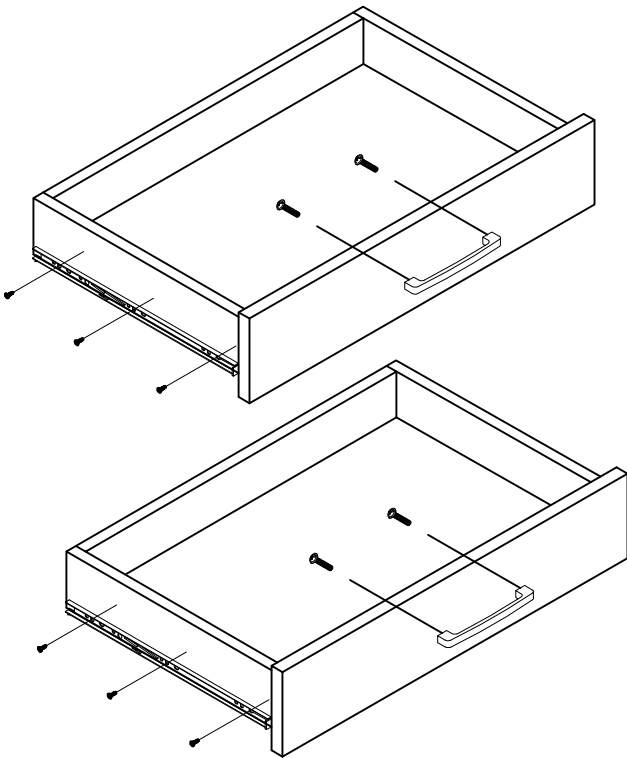

1. Lock the spare drawer slide block to the drawer.
2. Install the drawer handle with 4*23 handle screws.

HARDWARE LIST		
4*16mm screw	Drawer slides	
F 12PCS	E-2 4PCS	
4*23mm screw	Drawer handle	
G 4PCS	I 2PCS	

STEP 10

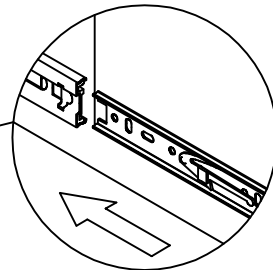
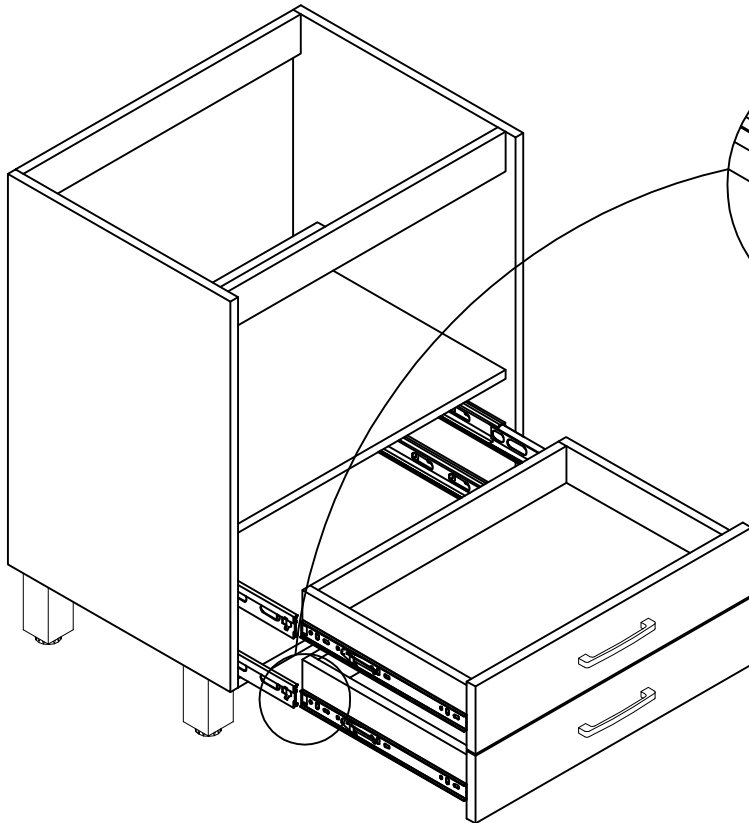

1. Align slide block with the trough on the guide rail, press the snap switch and press it forward to install the drawer.

2. Install drawer handles.

STEP 11

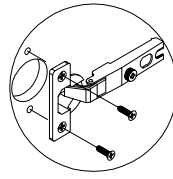
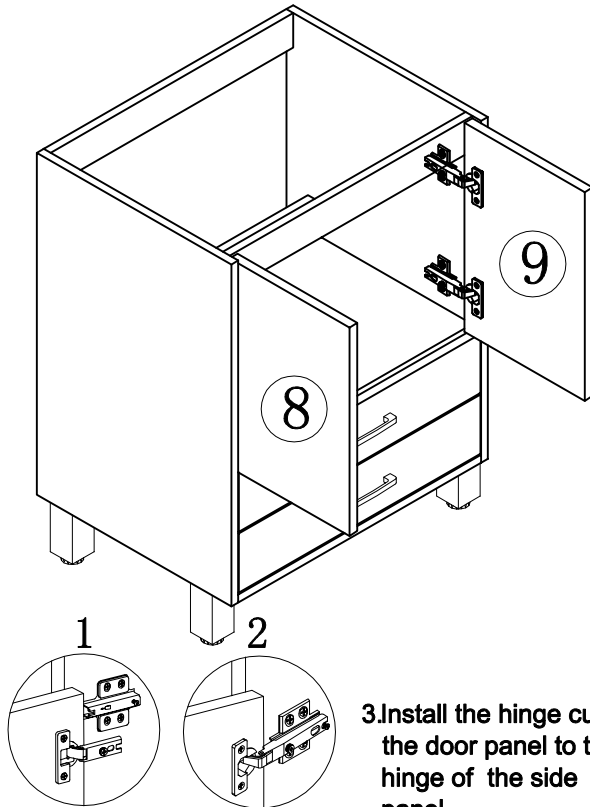

1. Install the hinge cup to the door panel with 4*16mm screws.

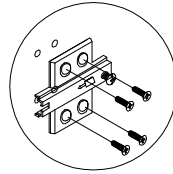

2. Install the hinge to the side panel with 4*16mm screws.

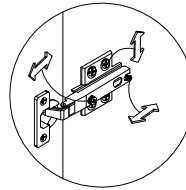

4. Adjust the door panel clearance.

3. Install the hinge cup on the door panel to the hinge of the side panel.

HARDWARE LIST

4*16mm screw	Door hinge	
F  24PCS	K  4PCS	

STEP 12

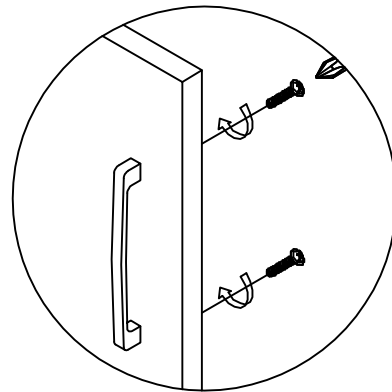
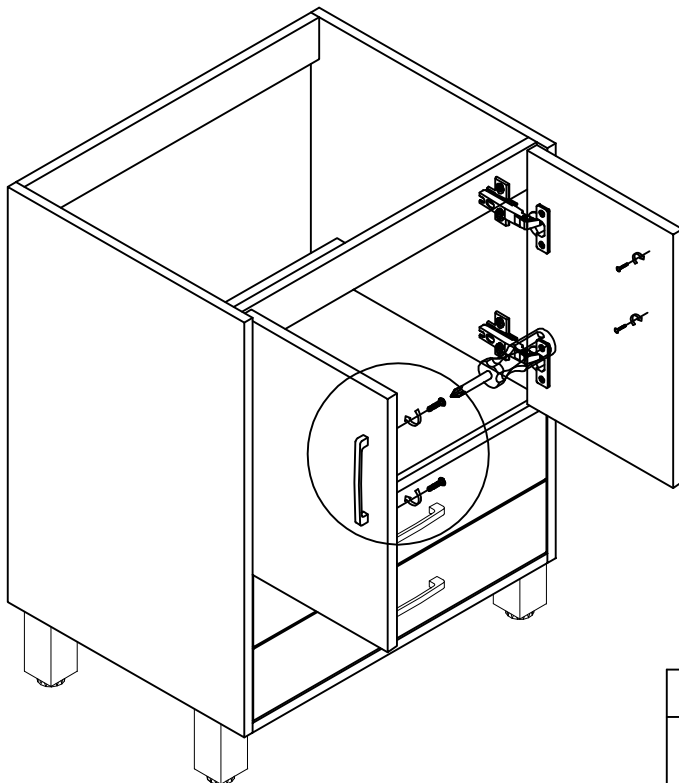

1. Install the door handle with 4*23mm handle screws.

HARDWARE LIST

4*23mm screw	Door handle	
G  4PCS	H  2PCS	



Choking hazard-Small Parts : This unit contains small parts, not for children under 3 years.

Tip-over hazard : Secure finished unit to wall stud using L-Bracket and wall screw (#10*1.5"W/out provided). If a wall stud is not neccessible , Consault your local hardware store for appropriate mounting hardware . Failure to properly install will result in product collapse or tip-over. Serious injury can occur .