

# ASSEMBLY INSTRUCTIONS

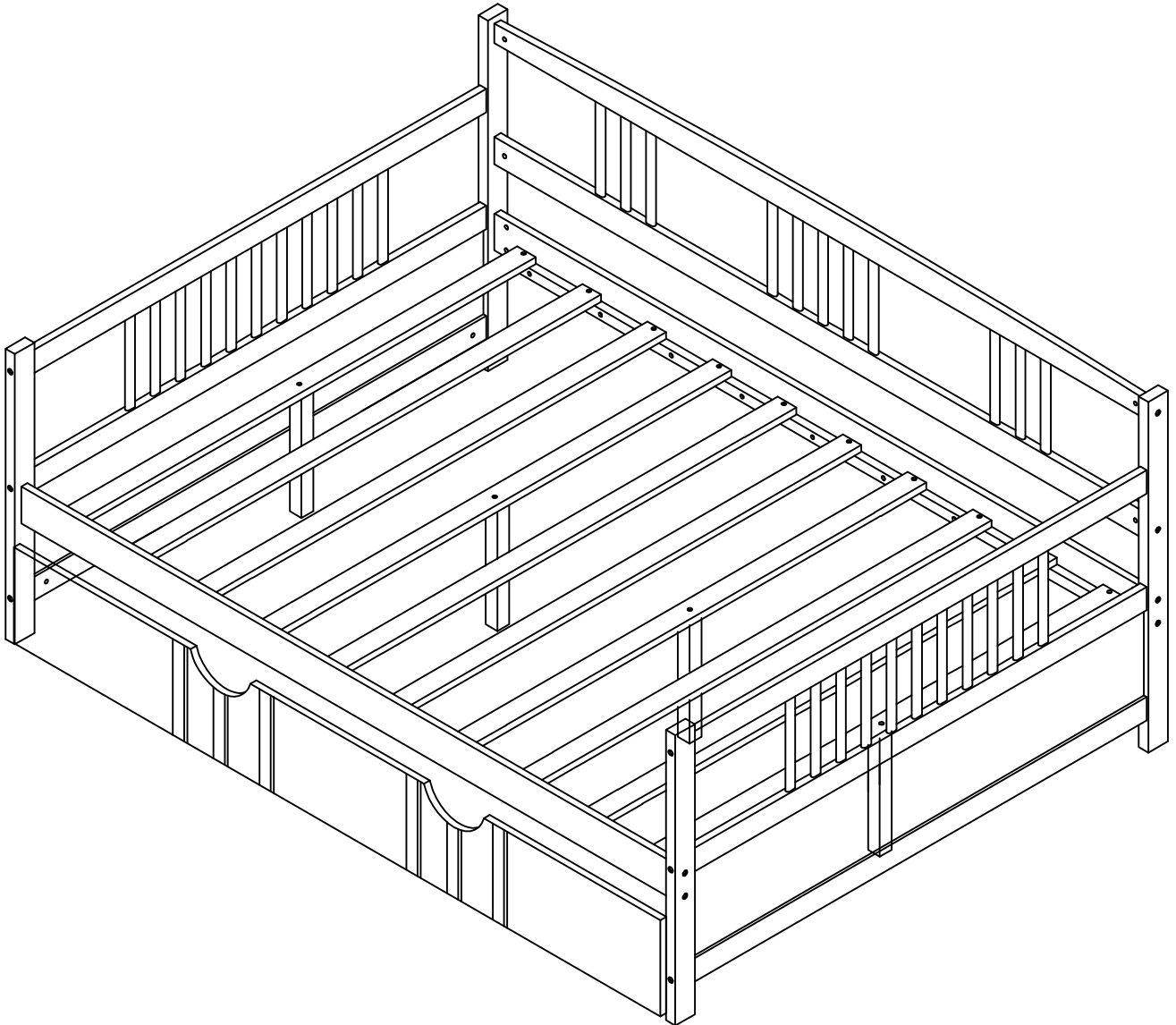

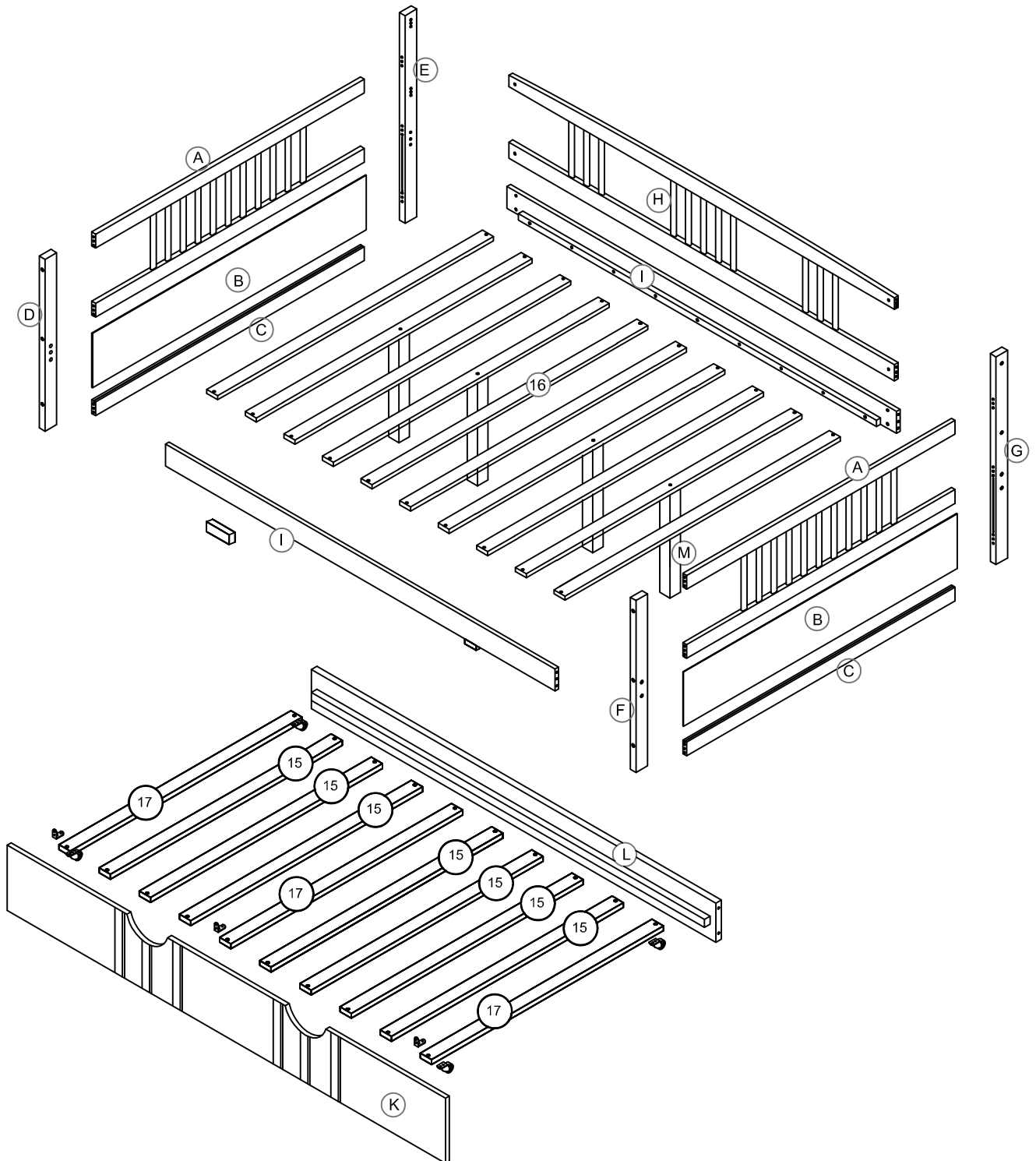





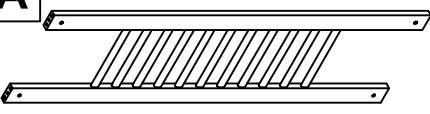

## FULL SIZE DAY BED WF198304/198305





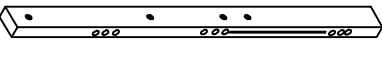
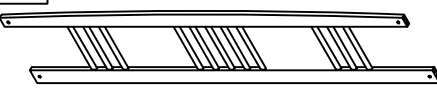

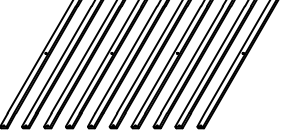



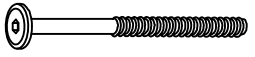
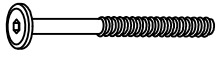

# Detail View



# Part List WF198304

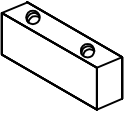
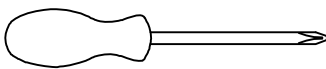

		
HB & FB - 2pcs	Side panel - 2pcs	Horizontal bar - 2pcs
		
Leg left (Front) - 1pc	Leg left (Back) - 1pc	Leg right (Front) - 1pc
		
Leg right (Back) - 1pc	Guard rail(Back)-1pc	Side rail(Back & Front)-2pcs
		
Slats - 1set (10pcs)	Support slat -4pcs	

## Hardware List (IN WF198304)

 <p>(Ø15)1/4"*110mm</p>	 <p>(Ø15)1/4"*85mm</p>	 <p>1/4"*15 (9.5mm)</p>
Hex-Head bolts (12pcs)	Hex-Head bolts (12pcs)	Horizontal-Hole bolts(12pcs)
 <p>Ø4*30mm</p>	 <p>(1/4")4.5*58mm</p>	 <p>Ø10*30mm</p>
Wood screws (38pcs)	Allen key (1pc)	Wood dowel (36pcs)
 <p>(Ø15)1/4"*35mm</p>		 <p>#4*20mm</p>
Hex-Head bolts (4pcs)	Wheels Ø32 ( 4pcs )	Wood Screws (8pcs)
 <p>60 x 20 x 2 (2mm)</p>	 <p>Ø6*50mm</p>	 <p>#4*15mm</p>
Pass L (3pcs)	Hex-Head bolts (6pcs)	Wood Screws (12pcs)
 <p>Wood block 2pcs</p>	<p>ASSEMBLY TOOLS REQUIRED ( NOT INCLUDED )</p> 	

PLEASE BE CAREFUL DO NOT DAMAGE THE HOLE POSITION WHEN YOU USE POWER TOOLS !

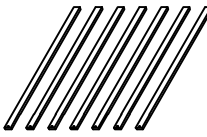
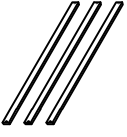
# Part List WF198305

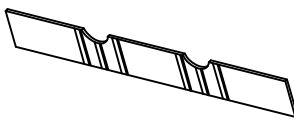

<b>15</b> 	<b>17</b> 	<b>L</b> 
Slats - 1set (7pcs)	Slats - 1set (3pcs)	Trundle back - 1pc
		<b>K</b> 
		Trundle front - 1pc

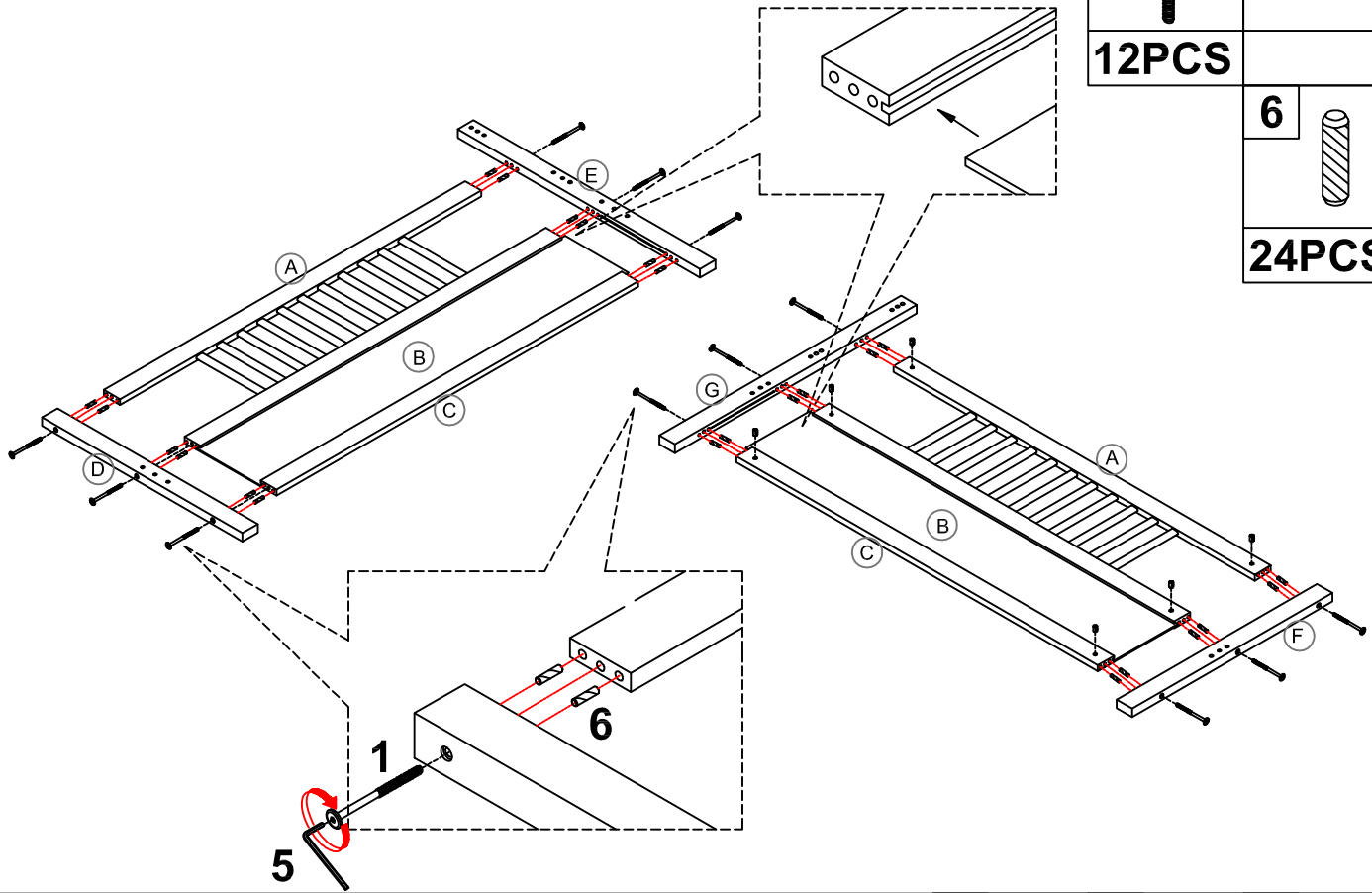
**STEP 1:**

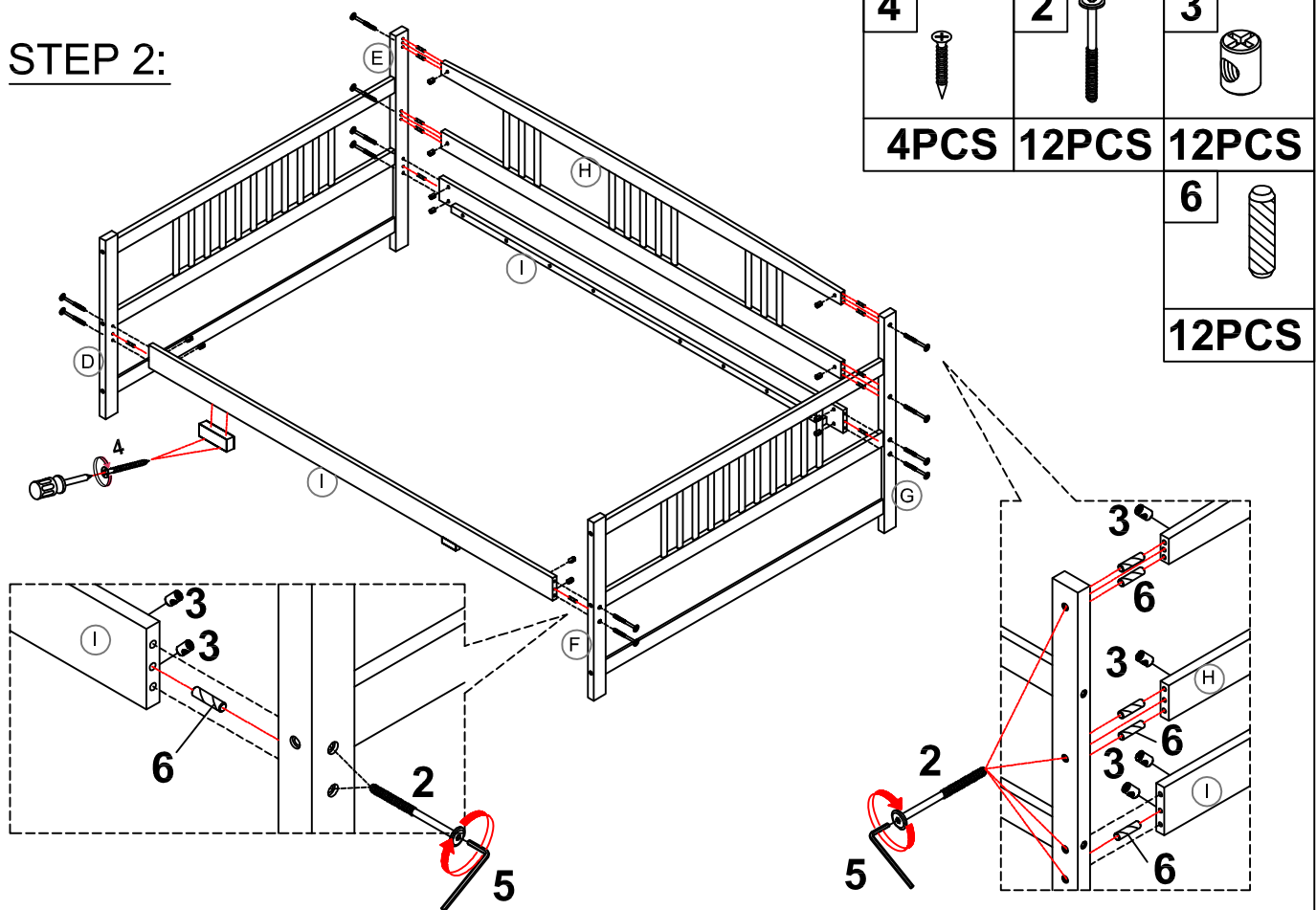

**STEP 2:**



9		8		12	
<b>8PCS</b>		<b>4PCS</b>		<b>12PCS</b>	

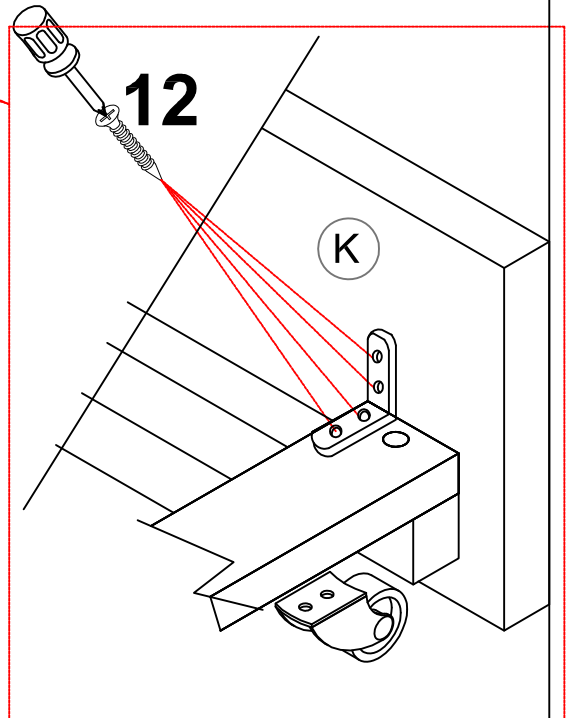
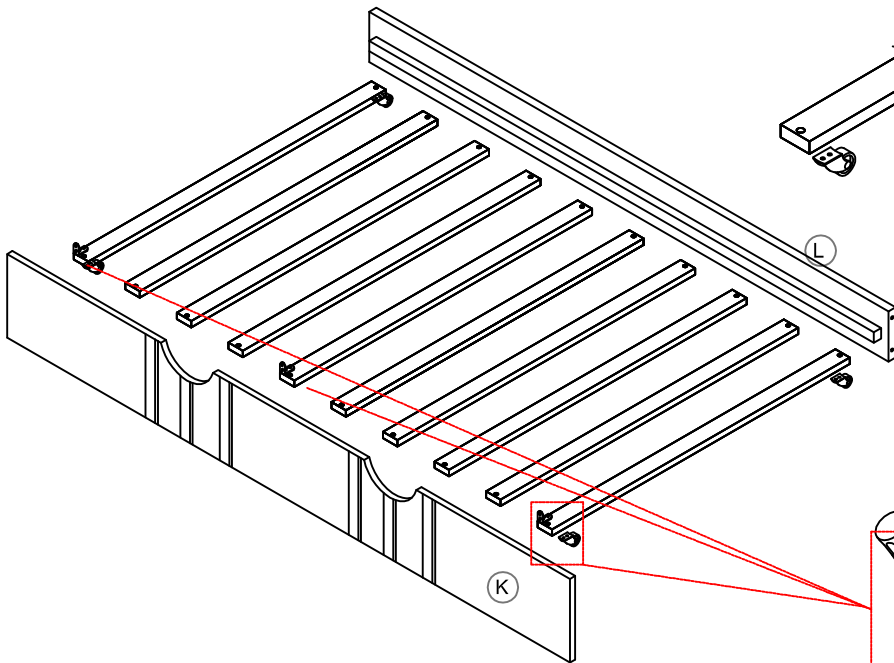
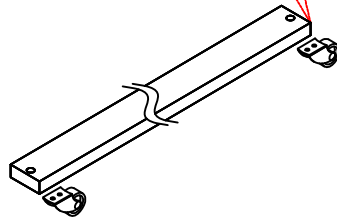
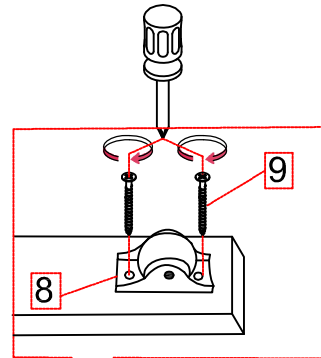

**STEP 3:**

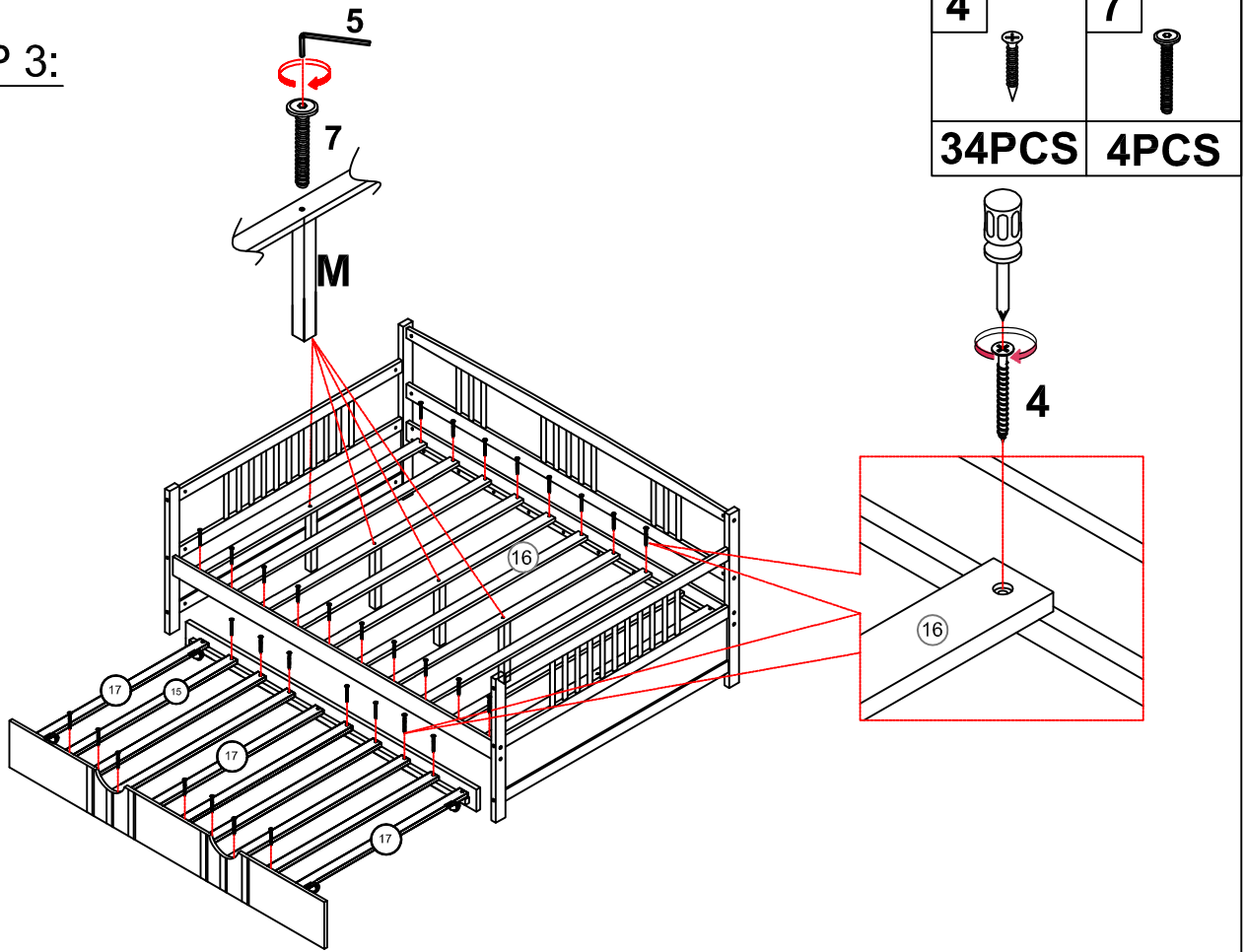

**STEP 4:**

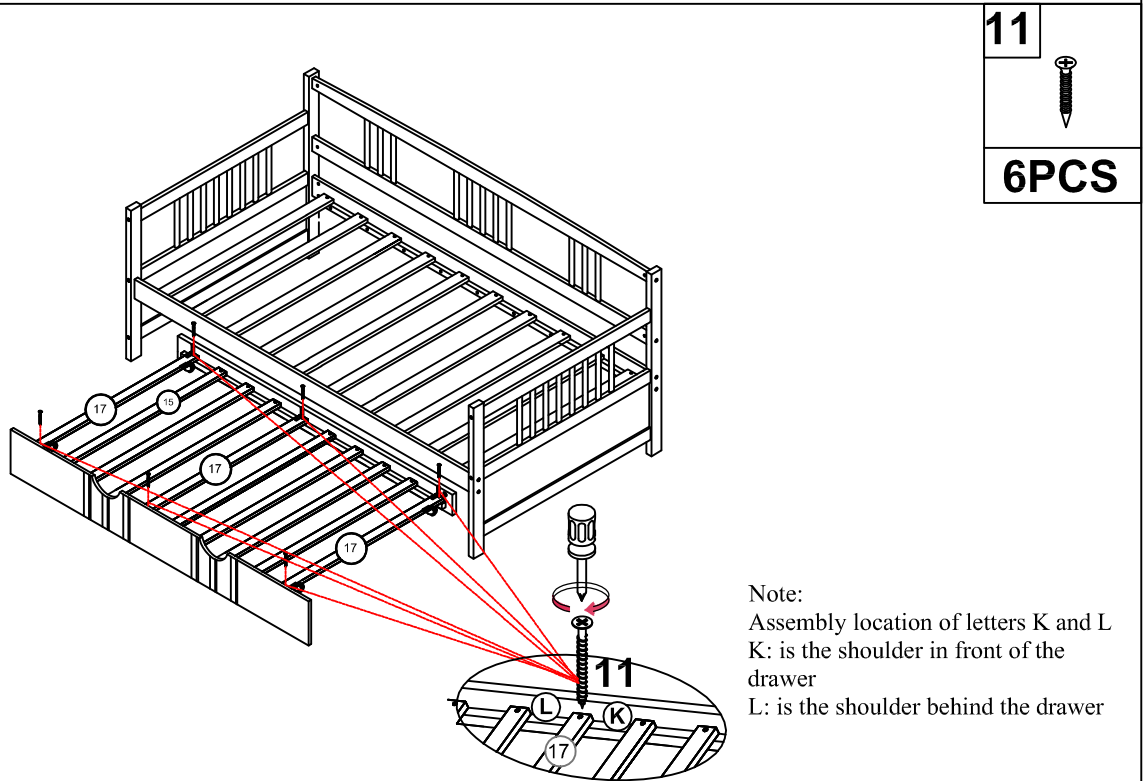

Note:  
 Assembly location of letters K and L  
 K: is the shoulder in front of the drawer  
 L: is the shoulder behind the drawer