











Assembly Instructions

Caution: You must read this before you proceed.

Care & Maintenance

- ⊘  ● Not for commercial use. For residential use only.
- ✓  ● Furniture may scratch floors. We recommend using furniture pads to protect your floors.
- ⊘  ● Do not put hot items directly on furniture surface.
- ⊘  ● Do not clean furniture with harsh cleansers or polish.
- ⊘  ● Do not place furniture under direct sunlight.
- ⊘  ● Do not place furniture near heating or cooling vents.
- ⊘  ● Do not write on furniture without a padded barrier to protect the surface.
- ⊘  ● Do not place furniture outside . For indoor use only.
- ⊘  ● Stains may be removed with mild soap solution and damp cloth.
- ⊘  ● Children should not climb or jump on the furniture.

- ✓  ● Dust and pick-up spills using a clean, non-colored, lint-free cloth.

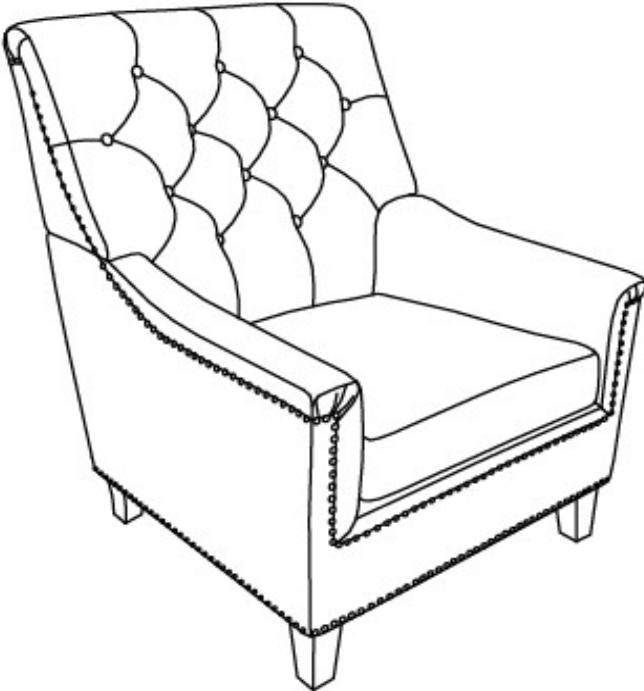

Please look in chair seat for hardware packs and legs.
Sets often ship in multiple boxes and may arrive a day or two apart.

CLUB CHAIR



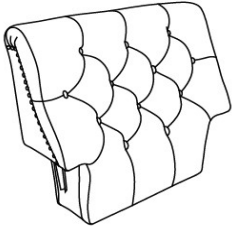

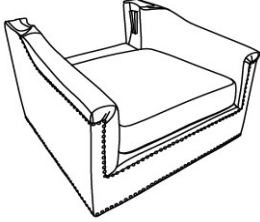
Parts List



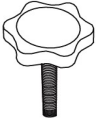

Label	Picture	Description	QTY
A		Backrest	1

B		Chair Seat	1
C		Front Leg	2
D		Hind Leg	2

Hardwares

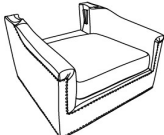
Label	Picture	Description	QTY
①		Screw(M8*40mm)	1
②		Gasket	7

Assembly Preparation

Before Begining Assembly:	A	B	C	D
				
	①	②		
	 x1	 x7		



- Read instructions, cover to cover-



- Have 2 adults on hand for assembly-



- Do not assemble on flooring or carpet-



- Assemble on a clean non-marring surface (packing foam)-



- Save all packaging until finished-

Assembly Steps

Overview

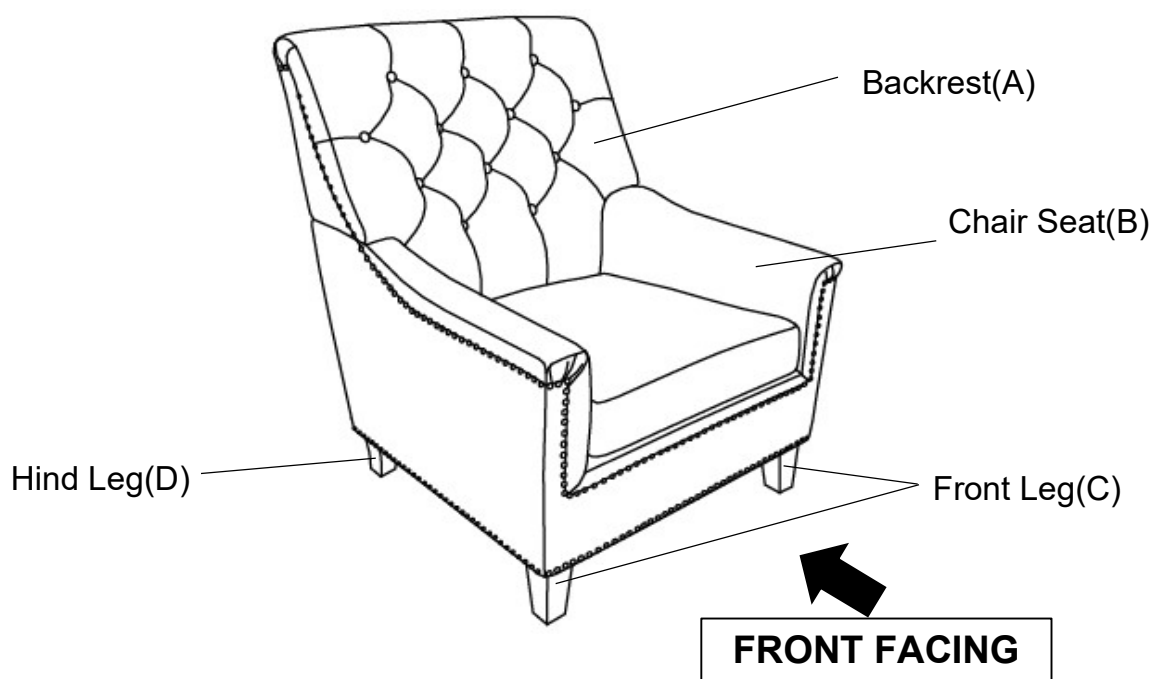

This Club Chair has multiple parts and may require up to 30 minutes to assemble. To give you an overview of the Chair parts, the above picture is to help you put the various parts into perspective. Please read through the instructions herebelow to familiarise the parts and steps before assembly.

Step 1

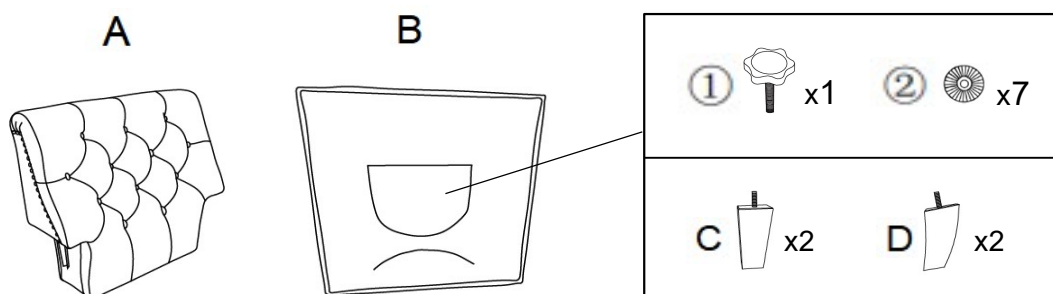

Position the Backrest(A) and Chair Seat(B) on a clean, non-marring surface, as shown.

Do not place on surface that can scratch or damage the upholstery.

Take out the 4 legs and Hardwares from the bottom of Chair Seat(B).

Step 2

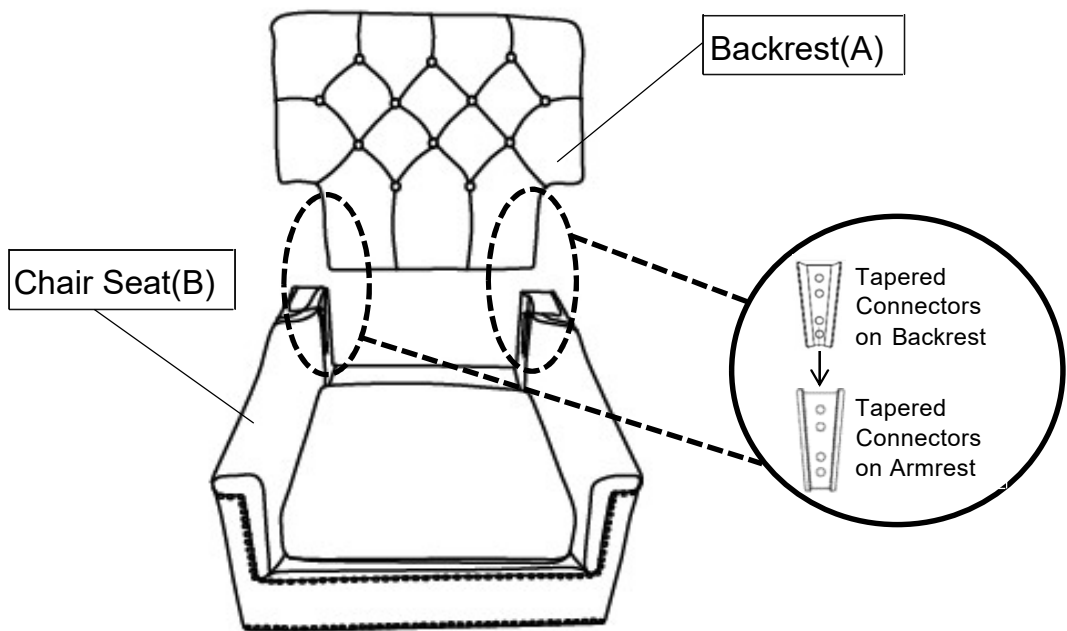

With assistance from an adult partner, lift the Backrest(A) up. Align the Tapered Connectors on the Backrest(A) and the Chair Seat(B). Push down on the Backrest(A) until it is fully locked into the Tapered Connectors.

Note: Make sure the Tapered Connectors on the Backrest(A) fully lock into the Tapered Connectors on the Chair Seat(B).

Note: If the bottom of the Backrest(A) completely touches the Chair Seat(B) edge, and it feels secure, not loose when pushing the Backrest(A) backwards, then the Backrest(A) is fully locked in position.

Step 3

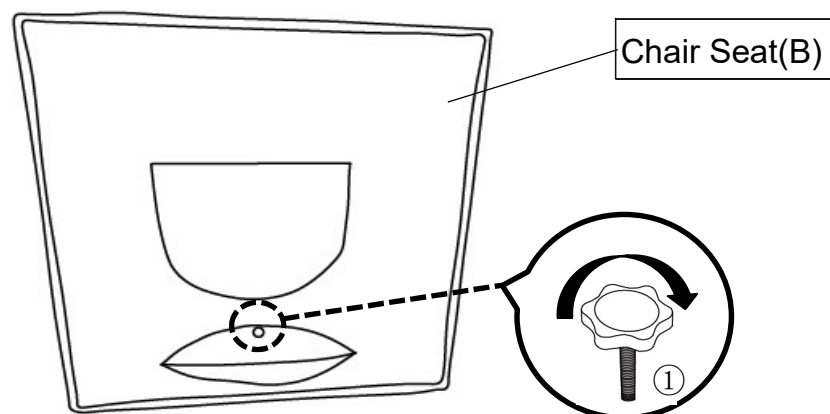

Turn the assembled Backrest as picture shown.
Attach Chair Seat(B) to Backrest(A) by screwing Screw(①) to the mounting position in the bottom of Chair Seat(B) , as above pictured shown .
Tighten the Bolts fully.

Step 4

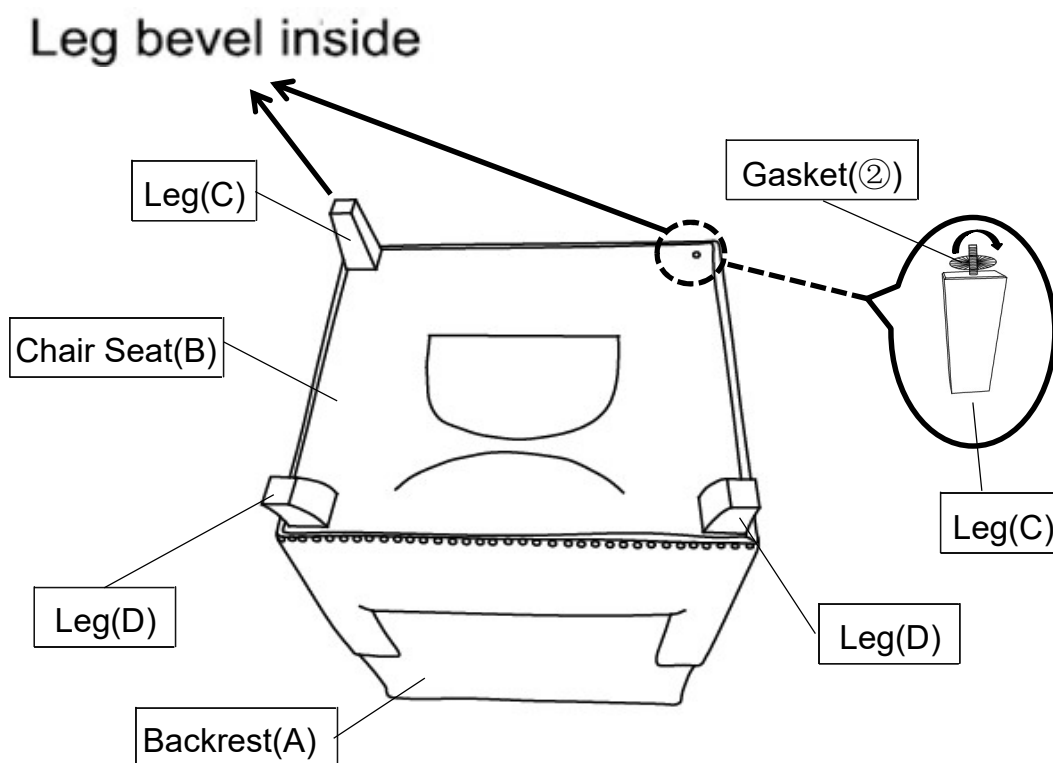

Attach the Front Leg(C) into the front mounting positions of Chair Seat(B) by using Gasket(②) , tighten by turning the Leg clockwise until it is completely secure.

Repeat this process with the another Front Leg(C).

Attach the Hind Leg(D) into the back mounting positions Chair Seat(B) by using Gasket(②),tighten by turning the Leg clockwise until it is completely secure.

Repeat this process with the another Hind Leg(D).

Note : The use of Washer Rings are OPTIONAL and is especially useful to help alleviate slight wobbleness. Some Legs may need more than one whilst some legs do not need any.

Step 5

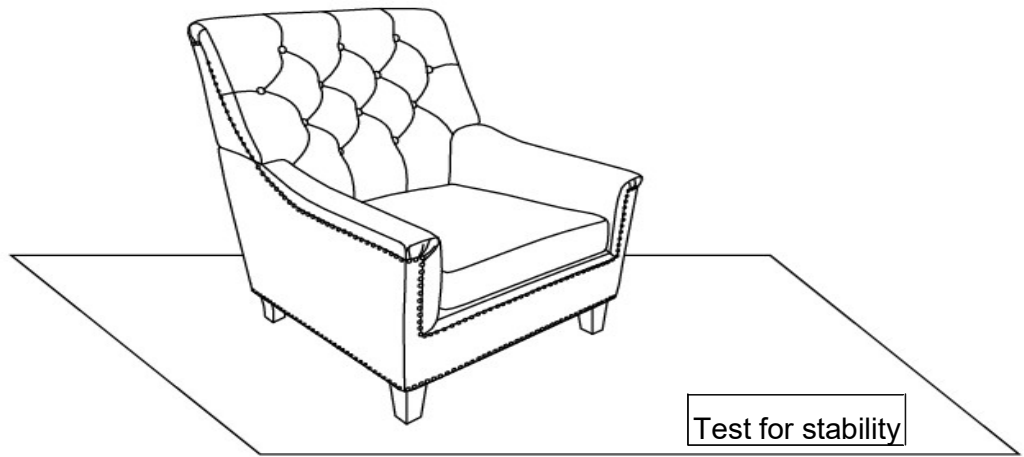

Your Club Chair is ready for use.

This Club Chair can only be used on a flat, level surface.