

**PL** Instrukcja montażu

**CZ** Návod k montáži

**D** Montageanleitung

**GB** Assembly instruction

**F** Model d'emploi

**HU** Szerelési útmutató

**I** Istruzione di montaggio

**NL** Handleiding voor de montage

**RU** Инструкция по монтажу

**RO** Instrucțiuni de montare

**SK** Návod k montáži

**TR** Montaj talimatı

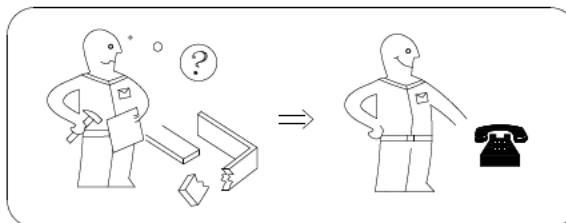
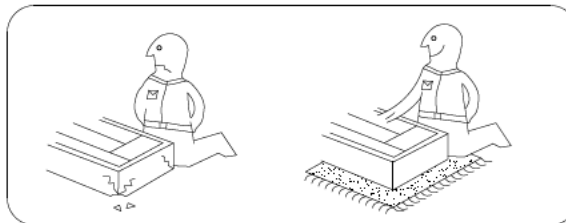
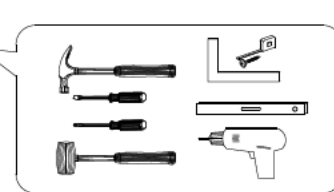
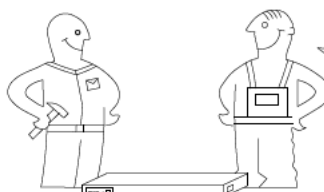

	<b>Uwaga • Upozornini • Achtung • Attention • Caution • Figyelem Attenzione • Opgelet • Внимание • Atentie • Upozornenie • Dikkat</b>	
<b>PL</b>	Czyszczenie należy wykonać wyłącznie za pomocą ściereczki lub lekko nawilżonego ręcznika Nie stosować środków czyszczących do szorowania	
<b>CZ</b>	Čistení je nutné vykonávať výhradne pomoci utěrky nebo lehce navlhčeného ručníku Nepoužívejte čističí prostředky obsahující abrazivní částice	
<b>D</b>	Bitte nur mit einem Staubtuch oder leicht feuchtem Lappen reinigen. Keine scheuernden Putzmittel verwenden	
<b>GB</b>	Please only clean with a duster or a damp cloth. Do not use any abrasive cleaners	
<b>F</b>	Le nettoyage se fait uniquement à l'aide d'un torchon ou d'une serviette légèrement mouillée	
<b>HU</b>	A tisztítás kizárólag torlóruha vagy enyhén nedvesített torlókendő segítségével végezhető Súroló hatású tisztítószereket nem szabad használni	
<b>I</b>	Pulire esclusivamente con un panno o un asciugamano umido	
<b>NL</b>	Reinig alleen met een stofdoek of een lichtjes vochtige doek. Gebruik geen schurende poetsmiddelen	
<b>RU</b>	Очищайте от пыли тряпкой или слегка влажной ветошью. Не допускается применение чистящих средств, не предназначенных для ухода за мебелью	
<b>RO</b>	Curățarea trebuie efectuată numai cu o cârpă sau cu un prosop ușor umezit Nu utilizați agenți de curățare abrazivi	
<b>SK</b>	Čistení je nutné vykonávať výhradne pomoci utierky alebo ľahko zvlhnutým ručníkom Nepoužívajte čistiaci prostriedky obsahujúci abrazívni častice	
<b>TR</b>	Lütfen sadece bir toz bezile veya hafif nemli yumuşak bir bezle siliniz. Aşındırıcı temizlik malzemeleri kullanmayınız	

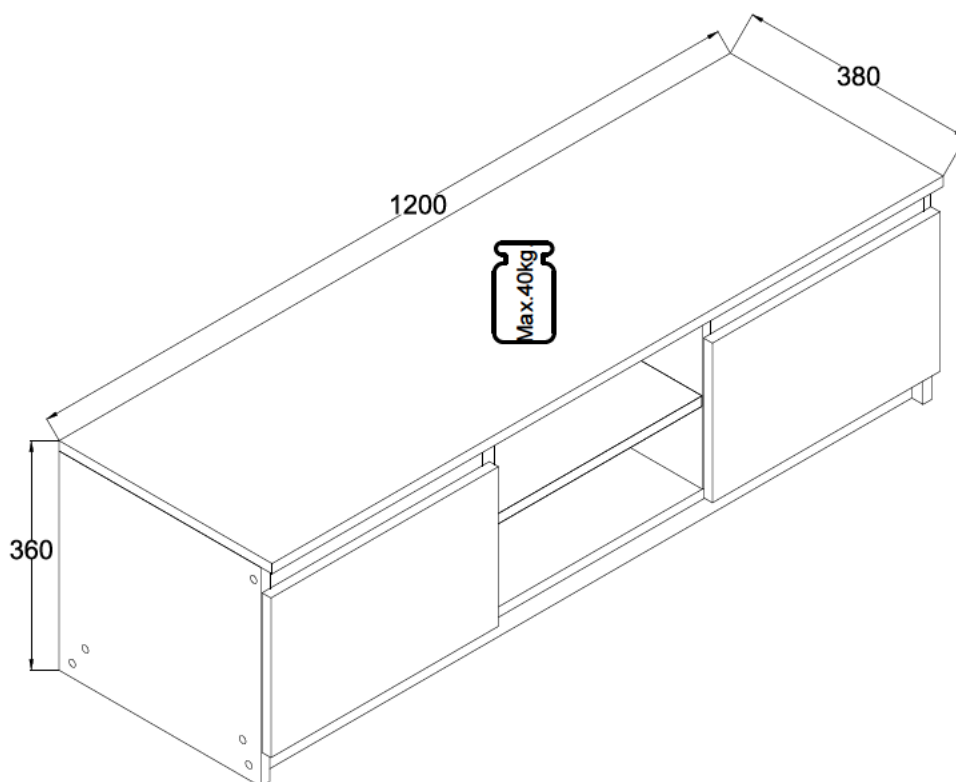

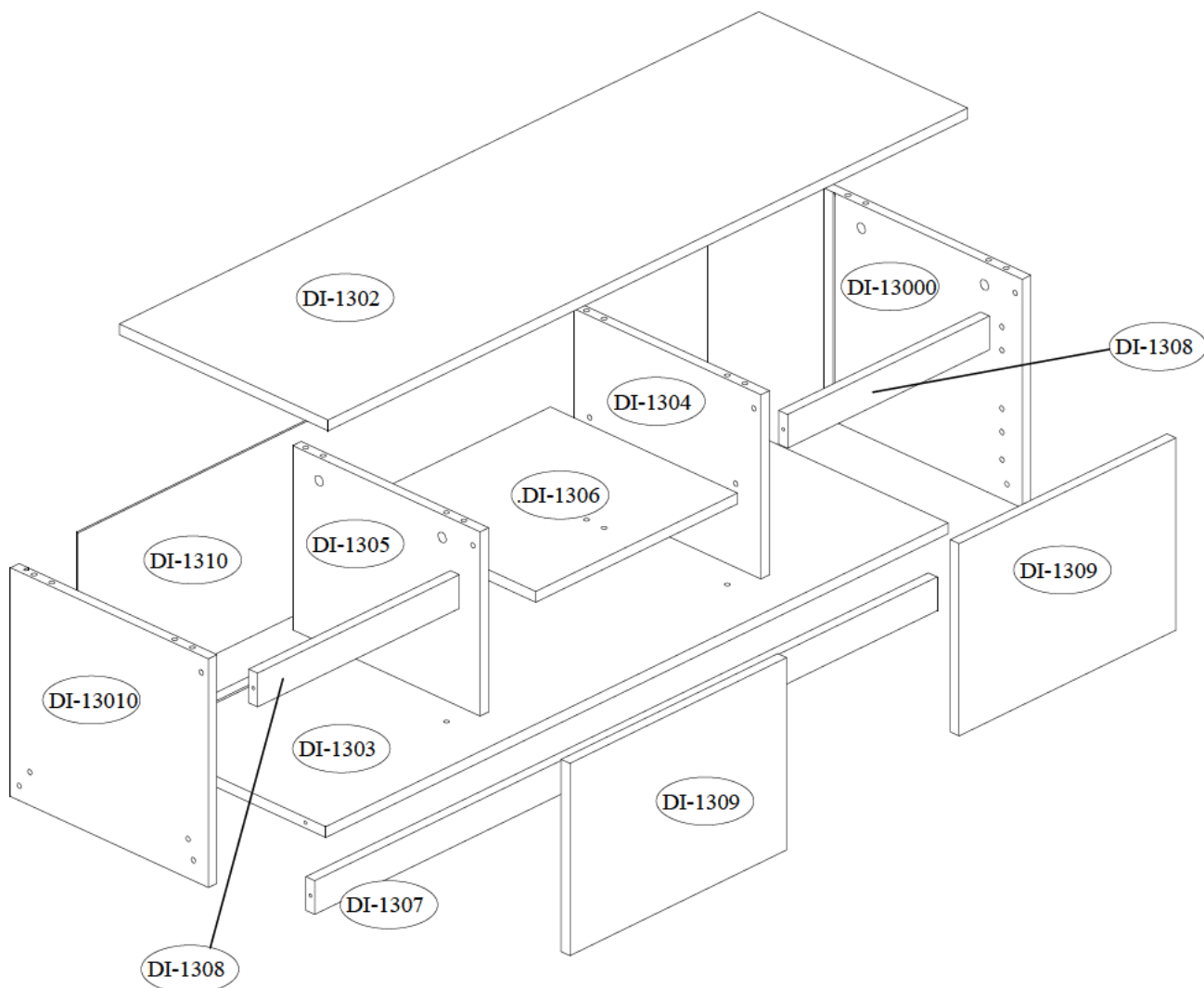
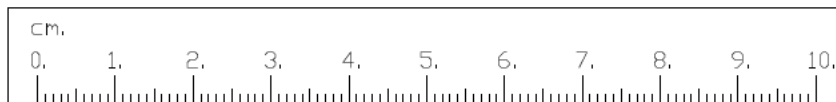
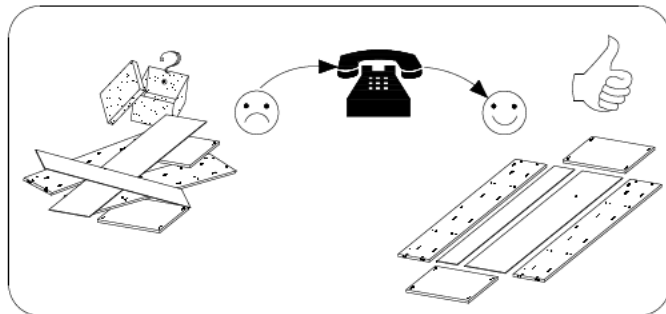
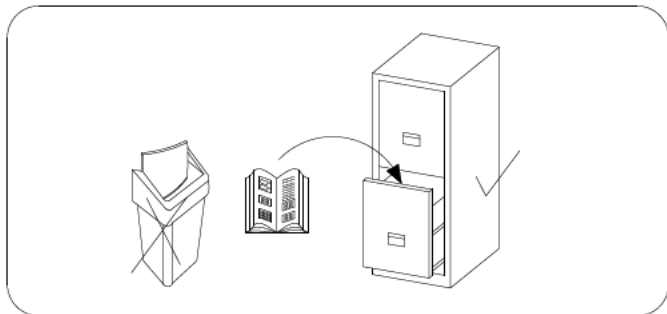

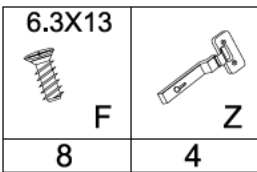
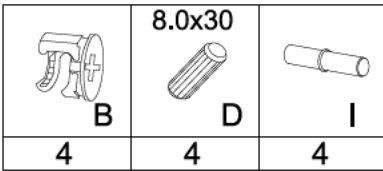
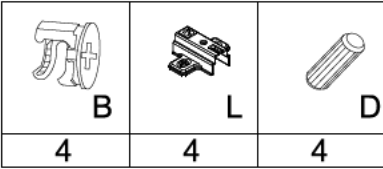
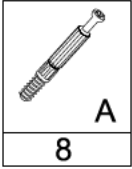

# VI-VII-VIII-IX-X

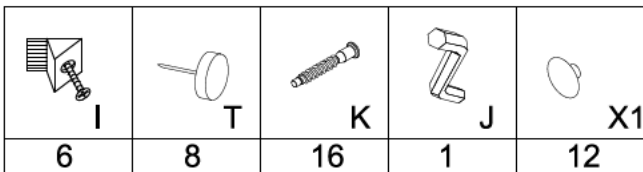

I

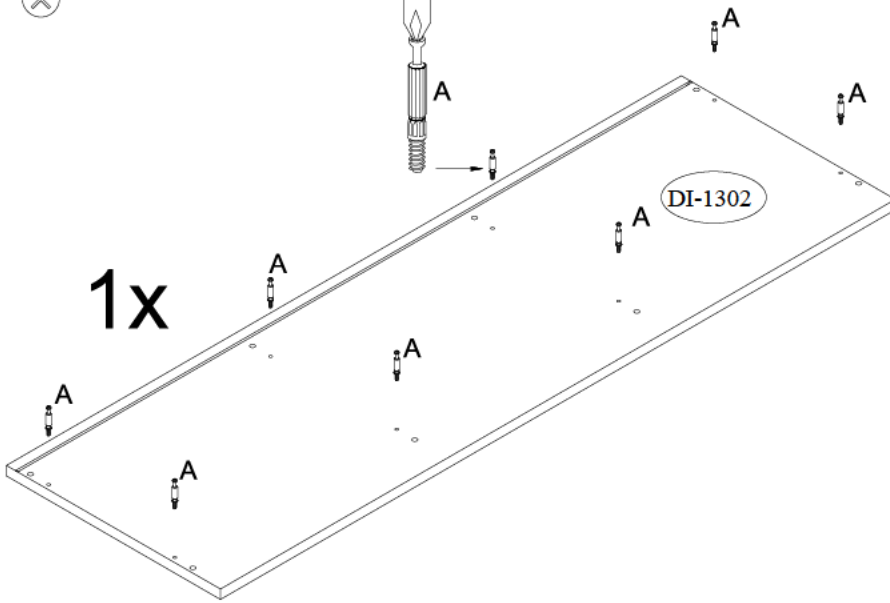
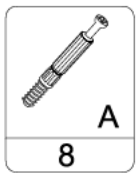
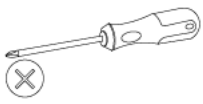

1x

DI-1302

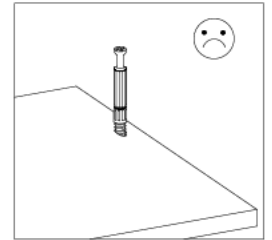
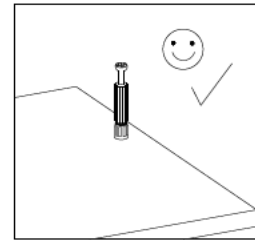
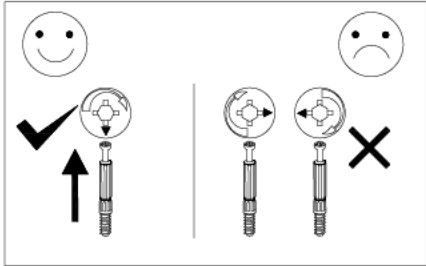

II

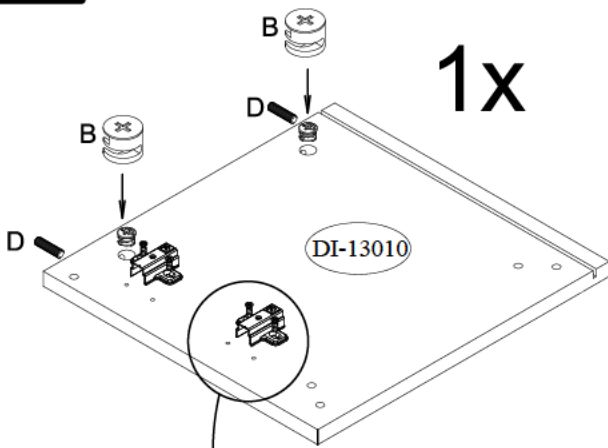
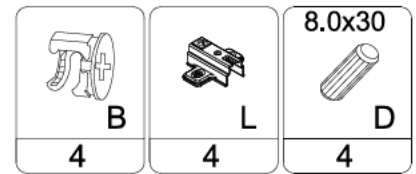

1x

DI-13010

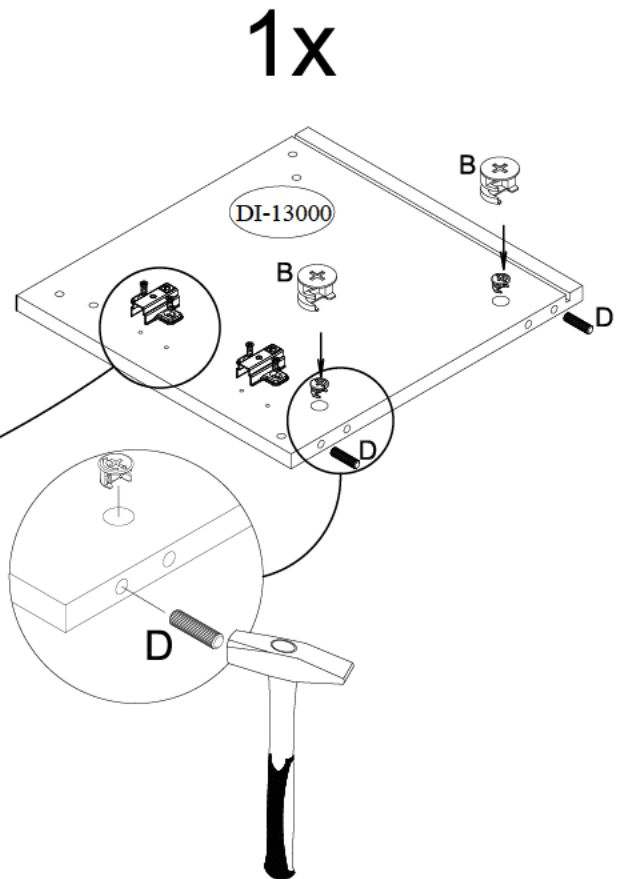

1x

DI-13000

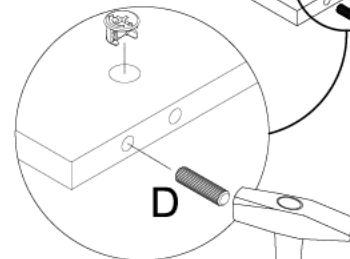
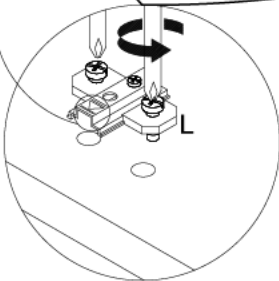

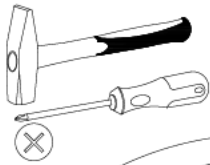

1x

B	I	D
4	4	4

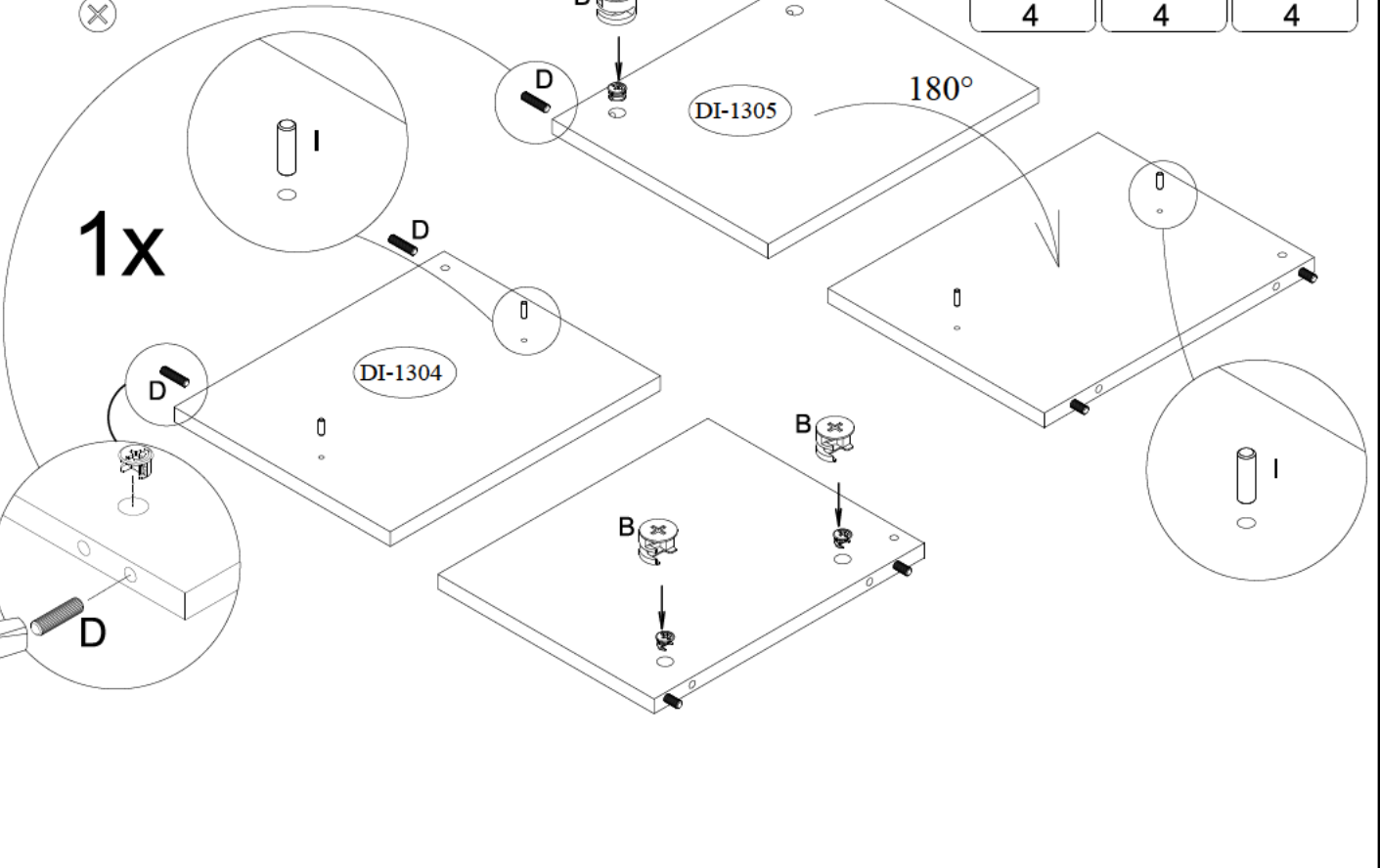

IV

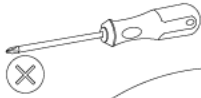

2x

F	Z
8	4

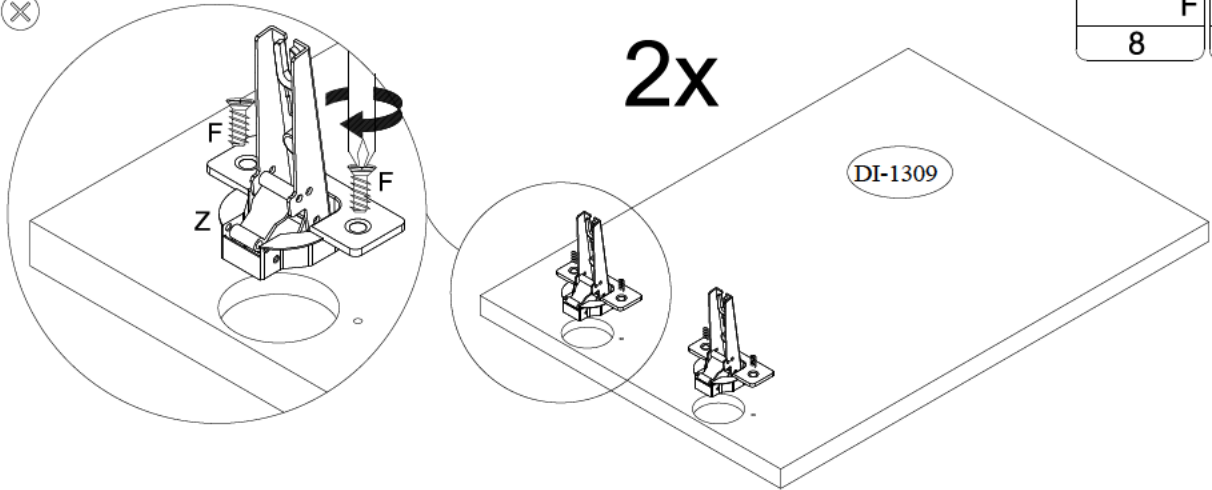

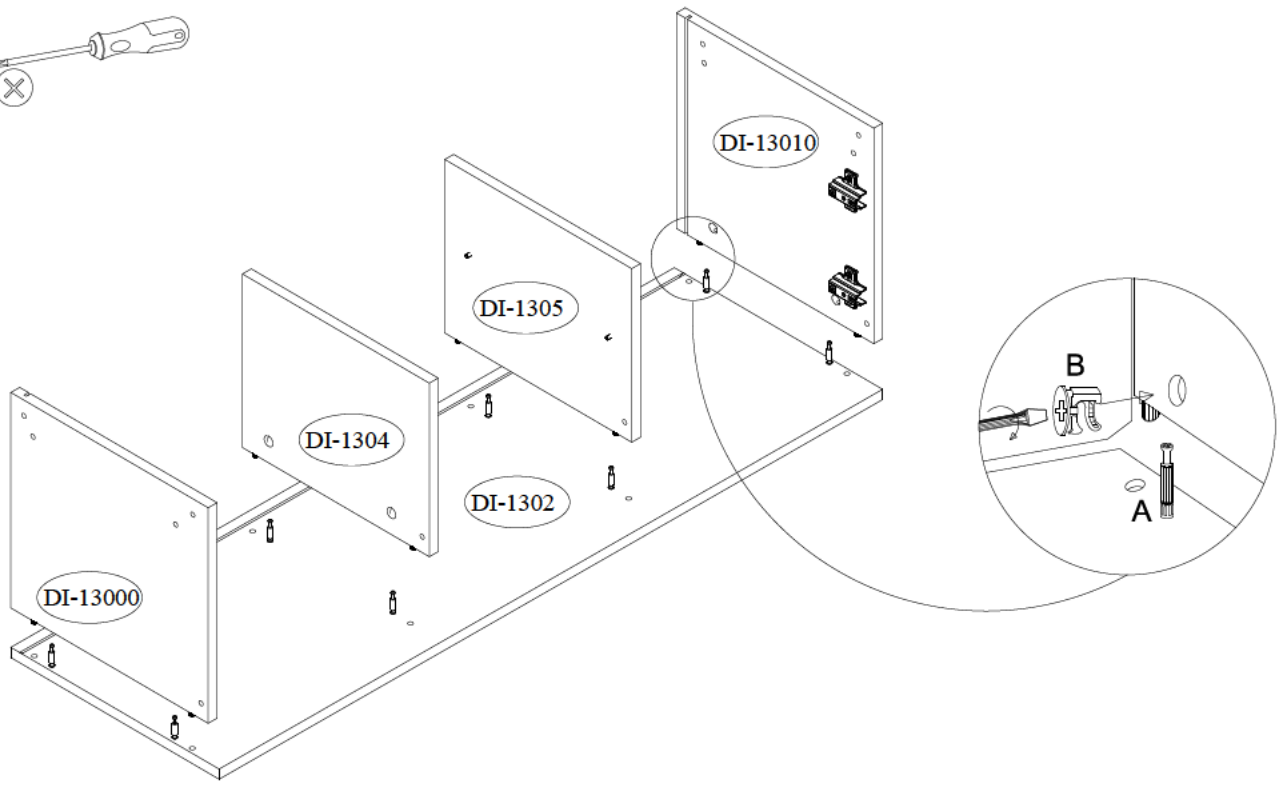
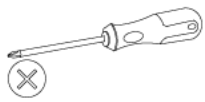
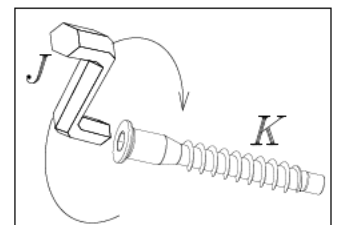
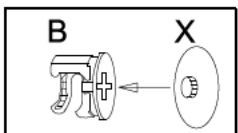
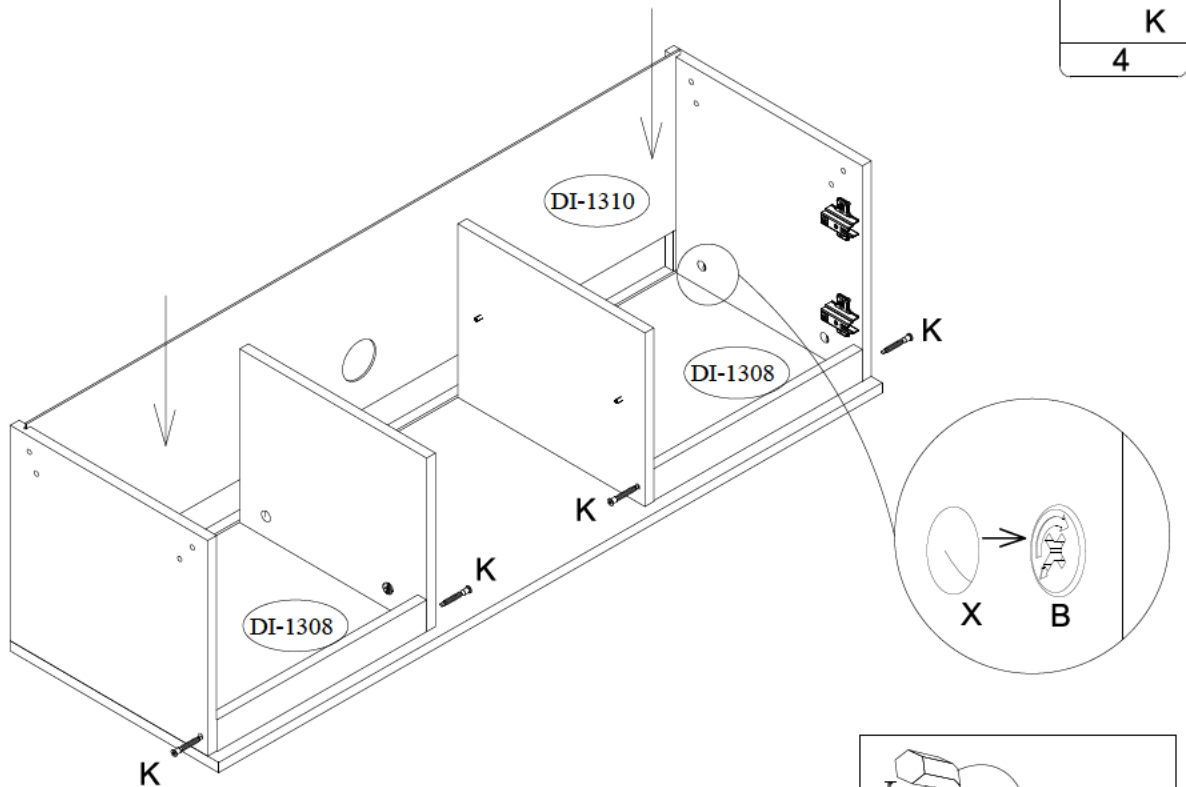
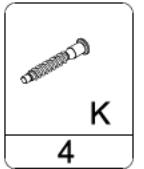
**V****VI**

# VII



K

8

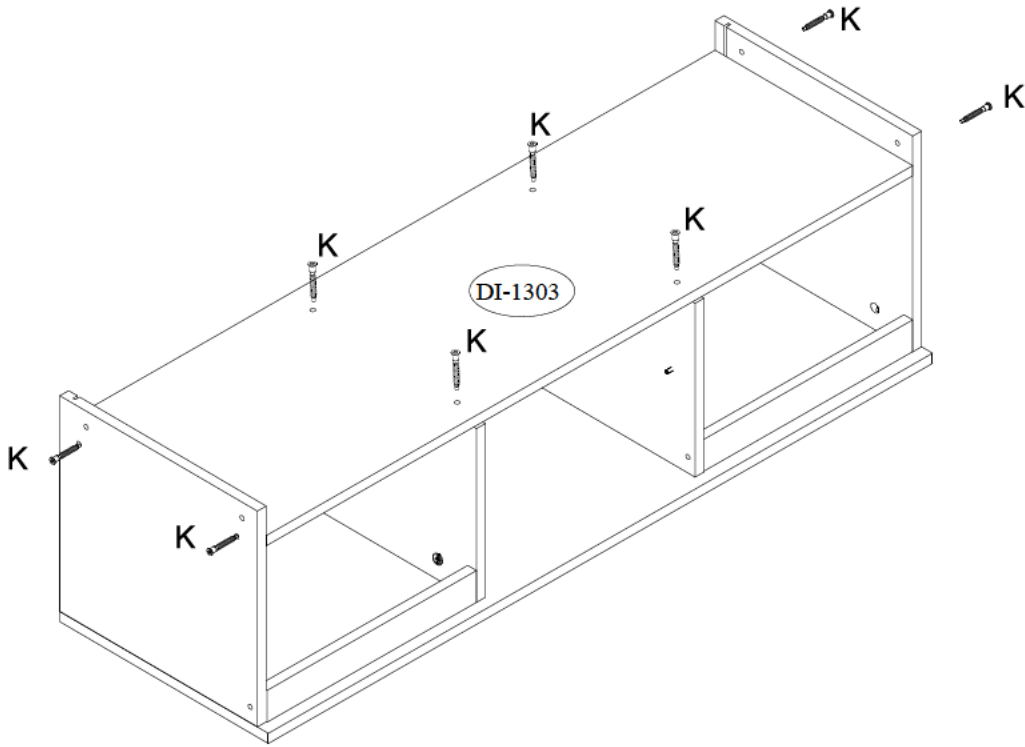

# VIII



T

8



K

4

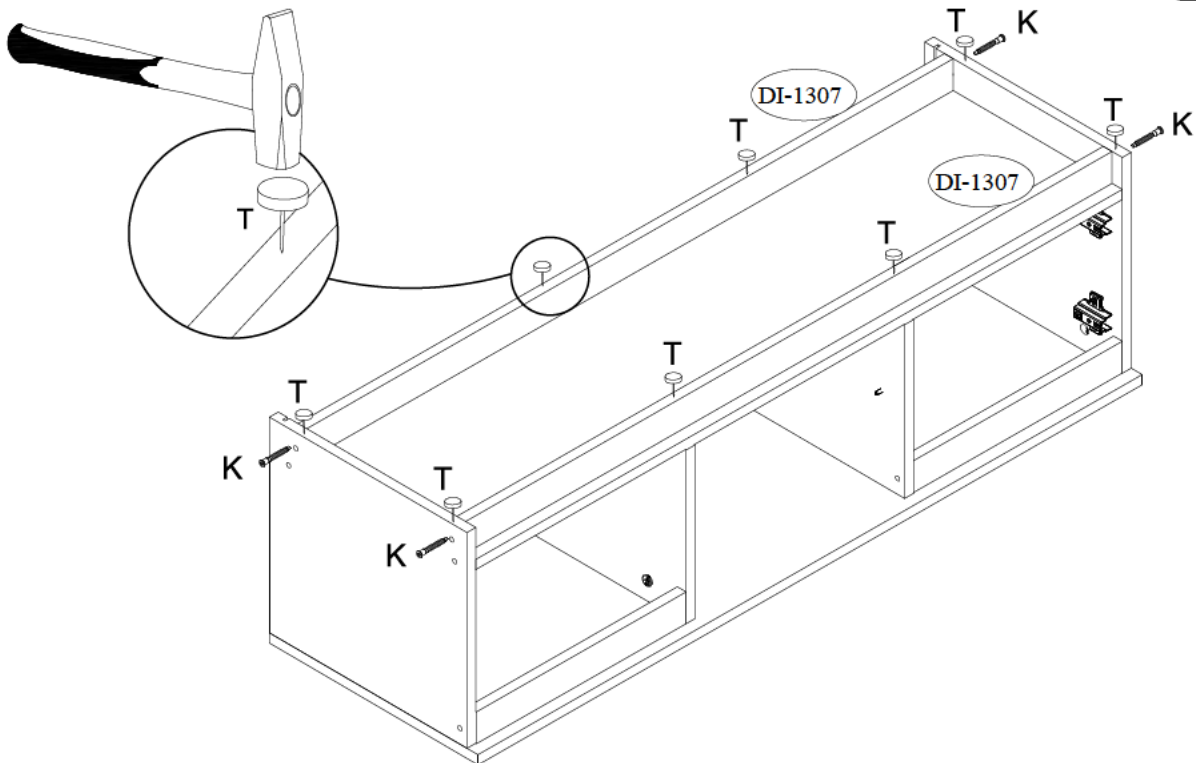

IX

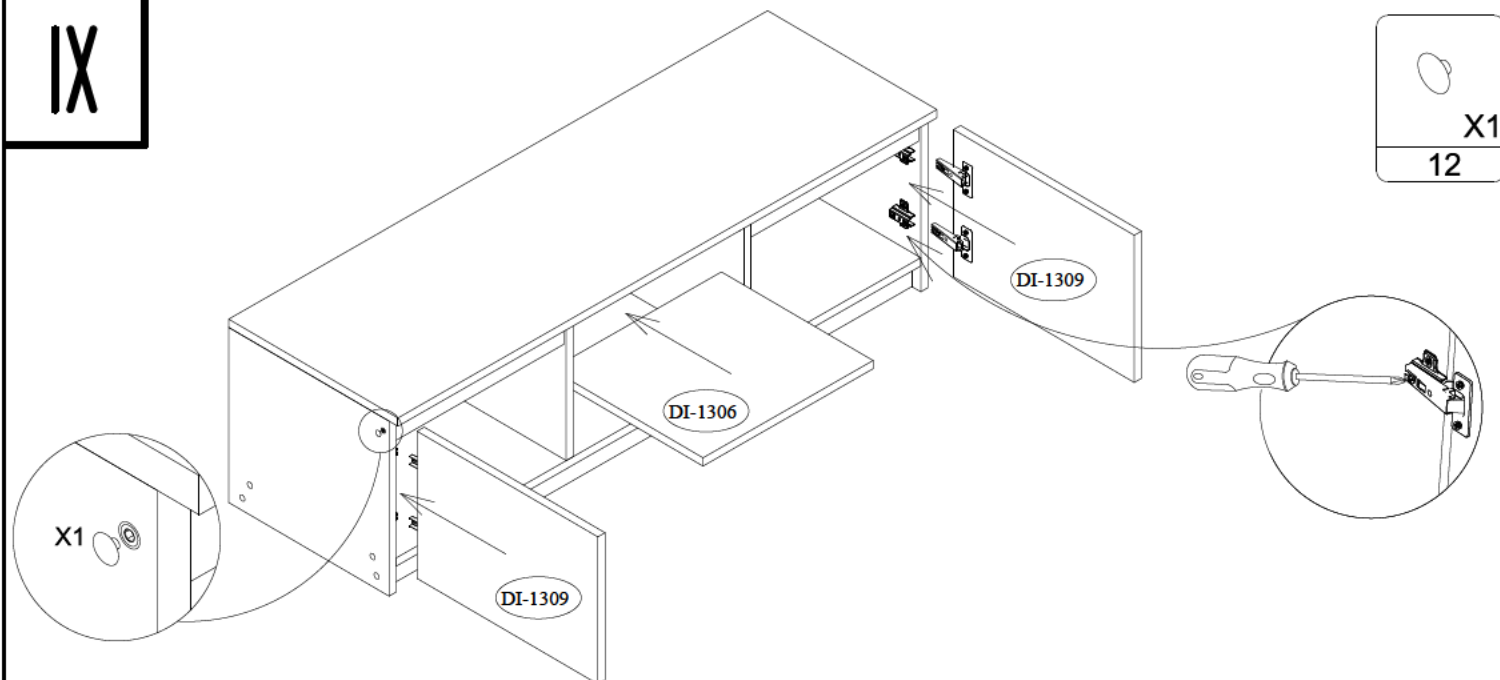

X

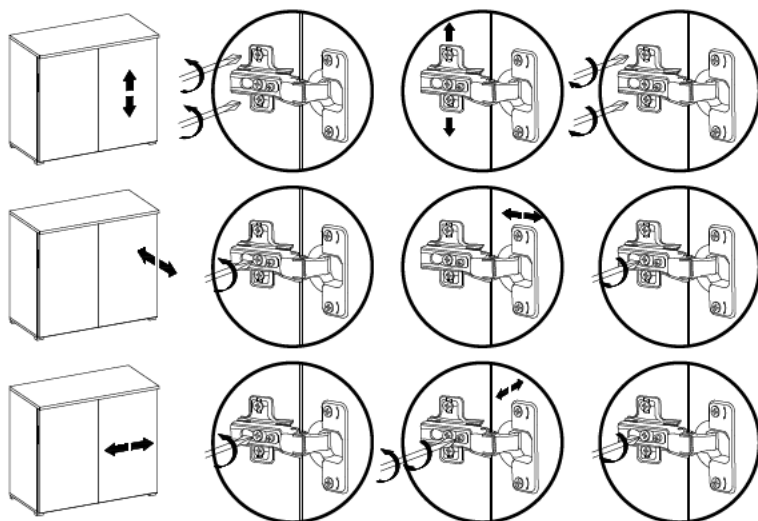
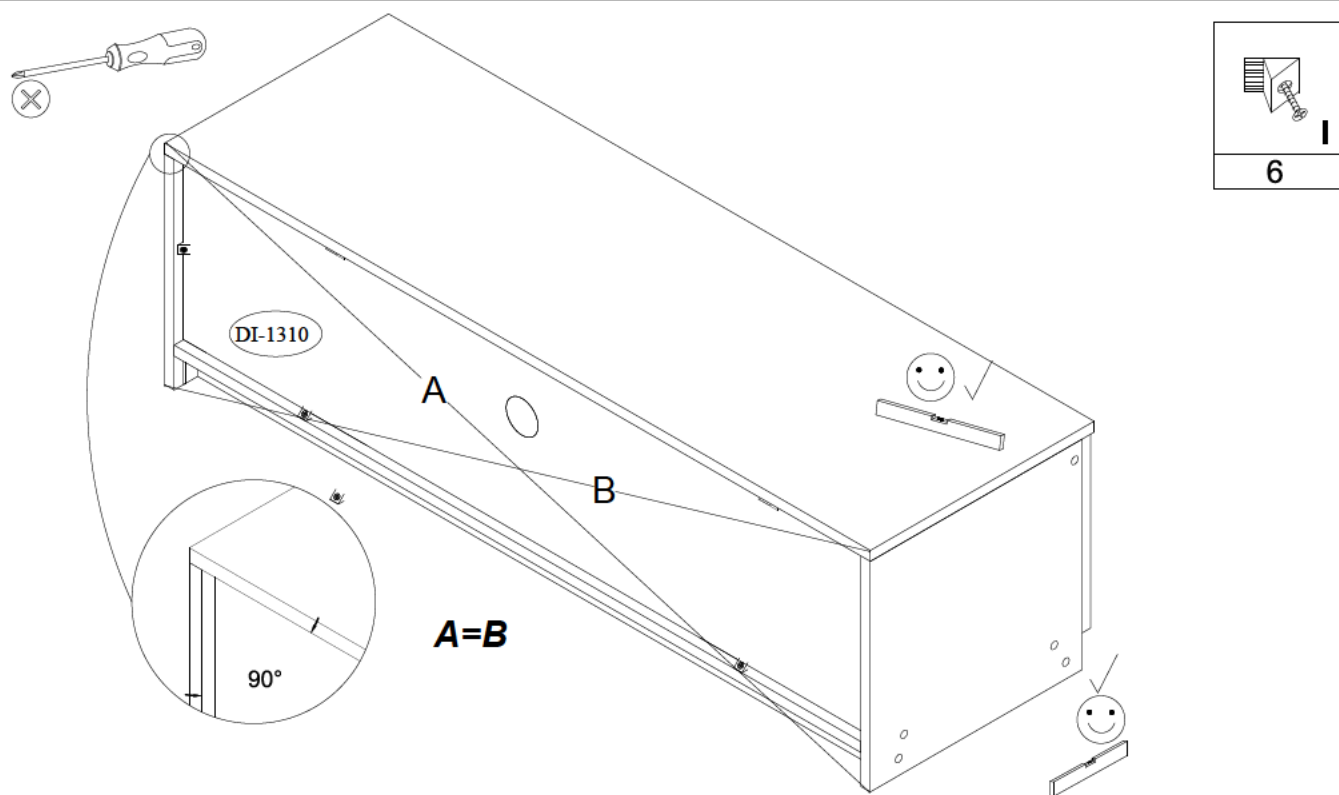

- (F) Mettre la porte (égaliser les gonds)
- (I) Regolare la porta (livellare le parentesi)
- (D) Turen einstellen (Scharniere justieren)
- (GB) Adjusting the doors (adjusting the hinges)
- (NL) Deuren instellen (scharnieren afstellen)
- (PL) Nastawic drzwi (wyrównac zawiasy)
- (TR) Kapıların ayarlanması (menteselerin seviye ayarı)
- (RU) Регулировка дверей (регулировка шарнира)
- (RO) Ajustări ușa (aliniati balamalele)
- (CZ) Seřid'te dveře (vyrovnajte závěsy)
- (SK) Zrad'te dvere (vyravnajte závesy)
- (HU) Állítsa be az ajtót (igazítsa be a zsanérokot)