

ASSEMBLY INSTRUCTION

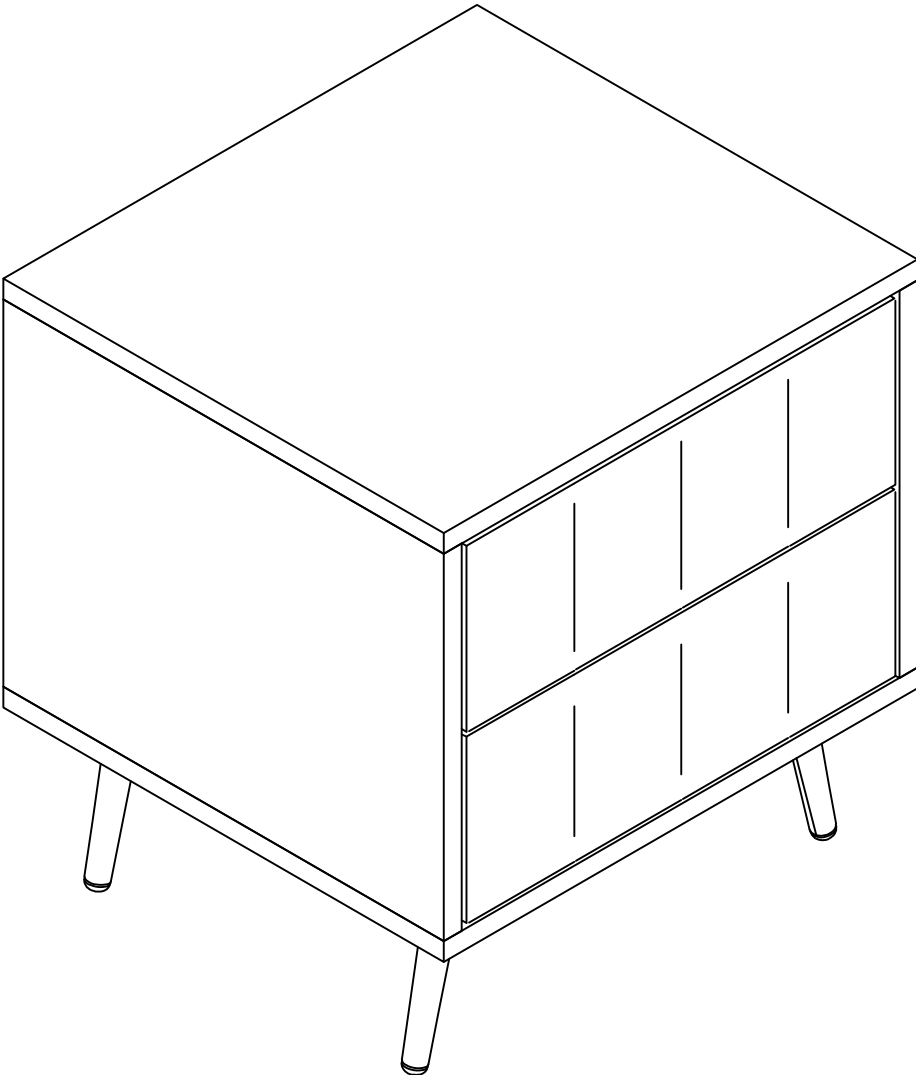

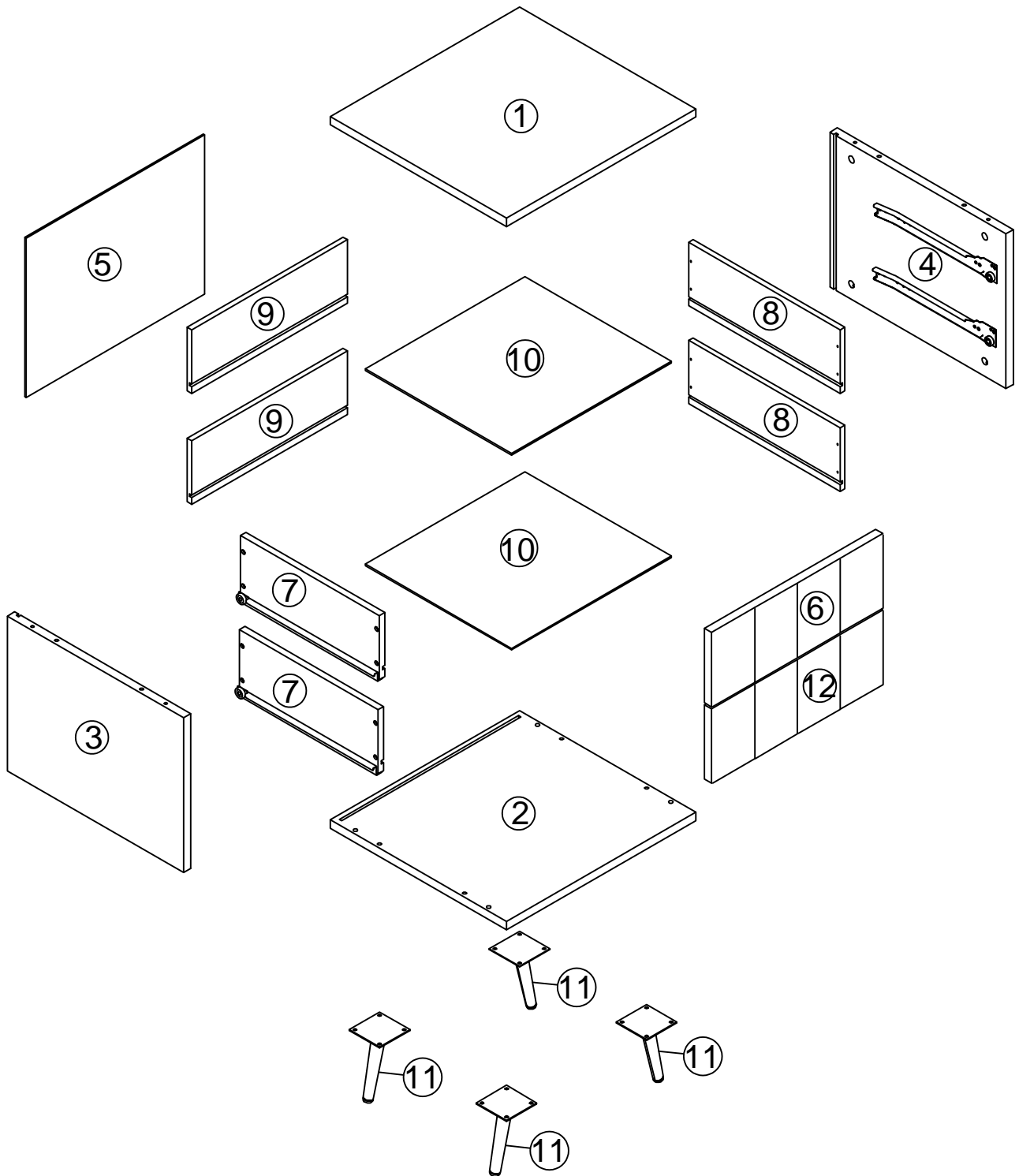



ASSEMBLY INSTRUCTION

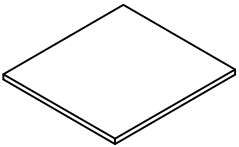
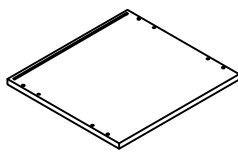
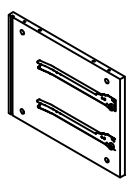
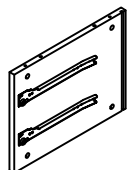
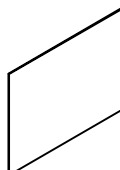
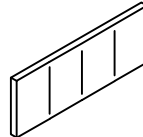
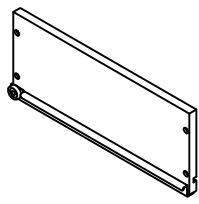
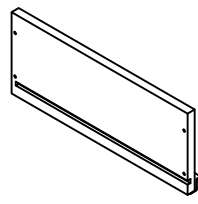
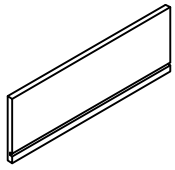
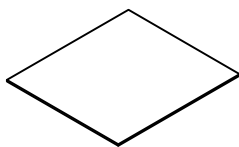
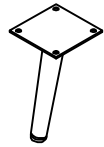
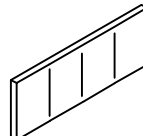

Part List

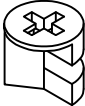
<p>1</p>  <p>Top Panel - 1pc</p>	<p>2</p>  <p>Bottom Panel - 1pc</p>	<p>3</p>  <p>Side Panels - 2pcs</p>
<p>4</p>  <p>Side Panels - 2pcs</p>	<p>5</p>  <p>Back Panel - 1pc</p>	<p>6</p>  <p>Upper-Drawers - Font Panel - 1pc</p>
<p>7</p>  <p>Drawers - Side Panels - 2pcs</p>	<p>8</p>  <p>Drawers - Side Panels - 2pcs</p>	<p>9</p>  <p>Drawers - Back Panels - 2pcs</p>
<p>10</p>  <p>Drawers - Bottom Panels - 2pcs</p>	<p>11</p>  <p>Metal Legs - 4pcs</p>	<p>12</p>  <p>Lower drawer- Font Panel - 1pc</p>

Hardware List

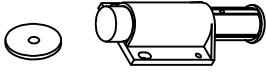
A  Link 1 -8Pcs	B  Link 2 -8Pcs	C  Ø8 x 30 mm Wood Dowel 8pcs
D  M4 x 30 mm Wood Screws 16pcs	E  M4 x 15 mm Wood Screws 26 pcs	F  Open latch - 2pcs

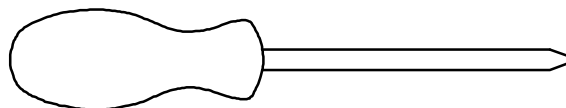



Assembly Tools Required (Not Included)

STEP 1-1: Following below illustration:

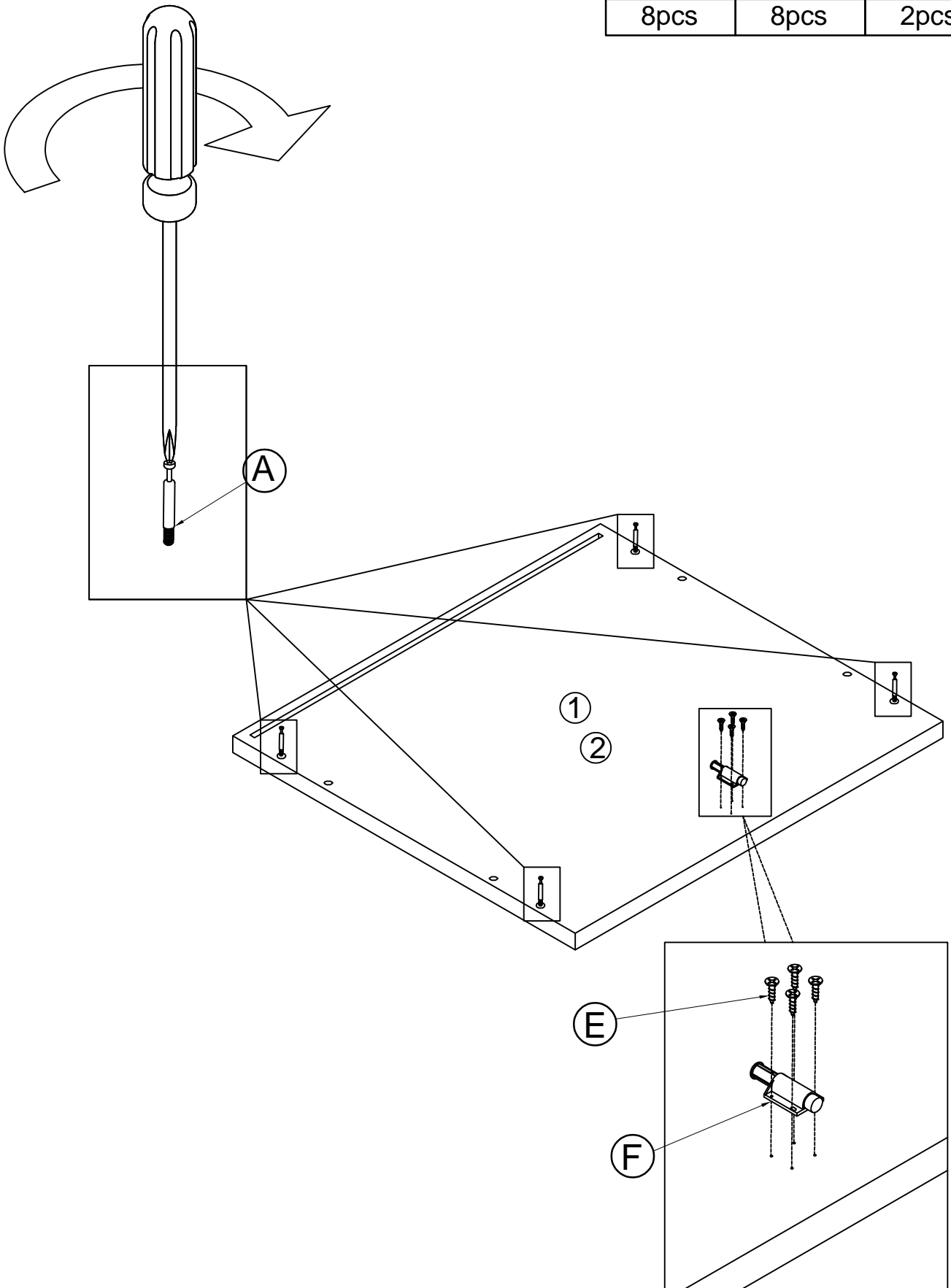
A	E	F
8pcs	8pcs	2pcs



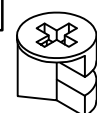

STEP 2: Following below illustration:

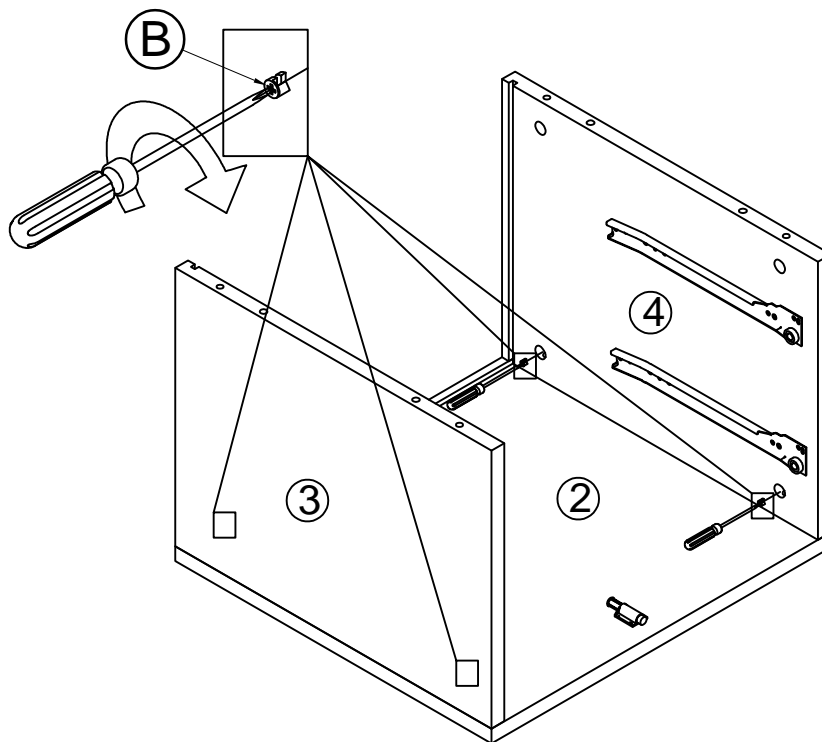
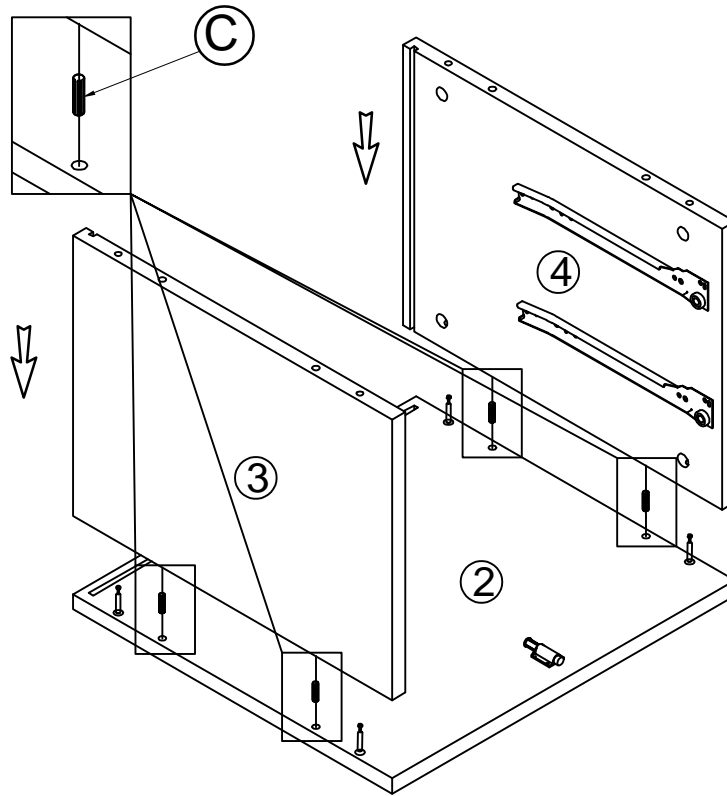
B 	C 
4pcs	4pcs



STEP 3: Following below illustration:

B 	C 
4pcs	4pcs

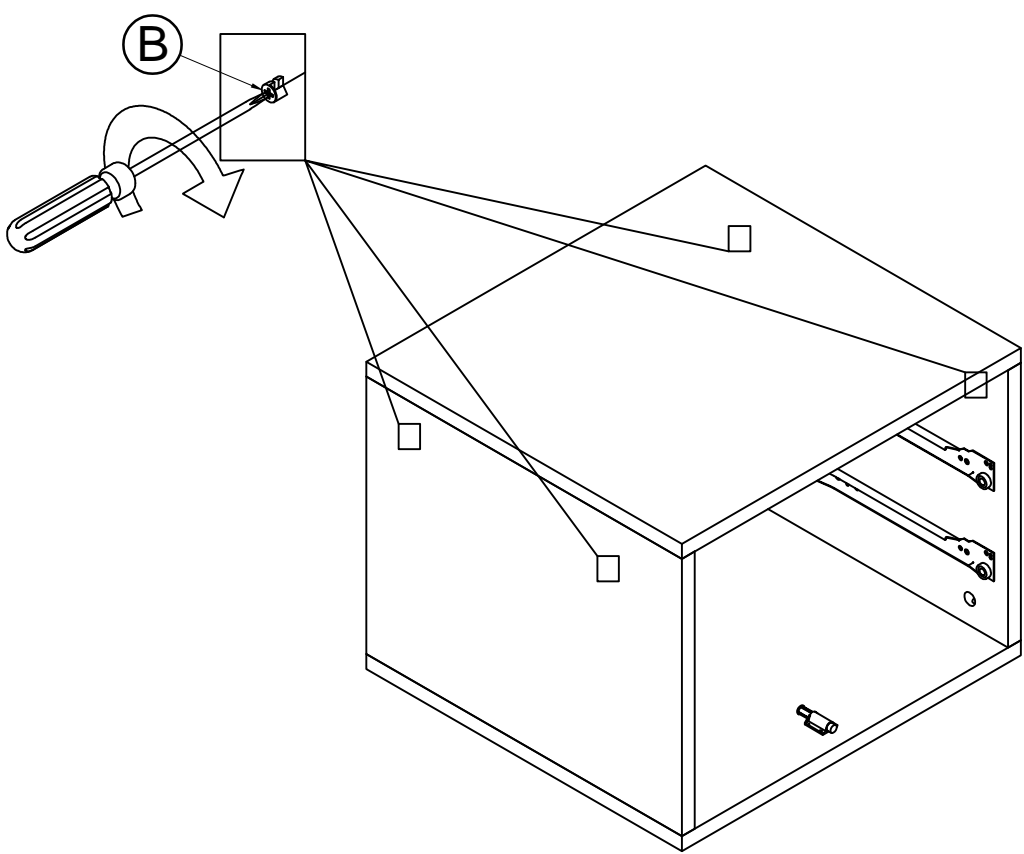
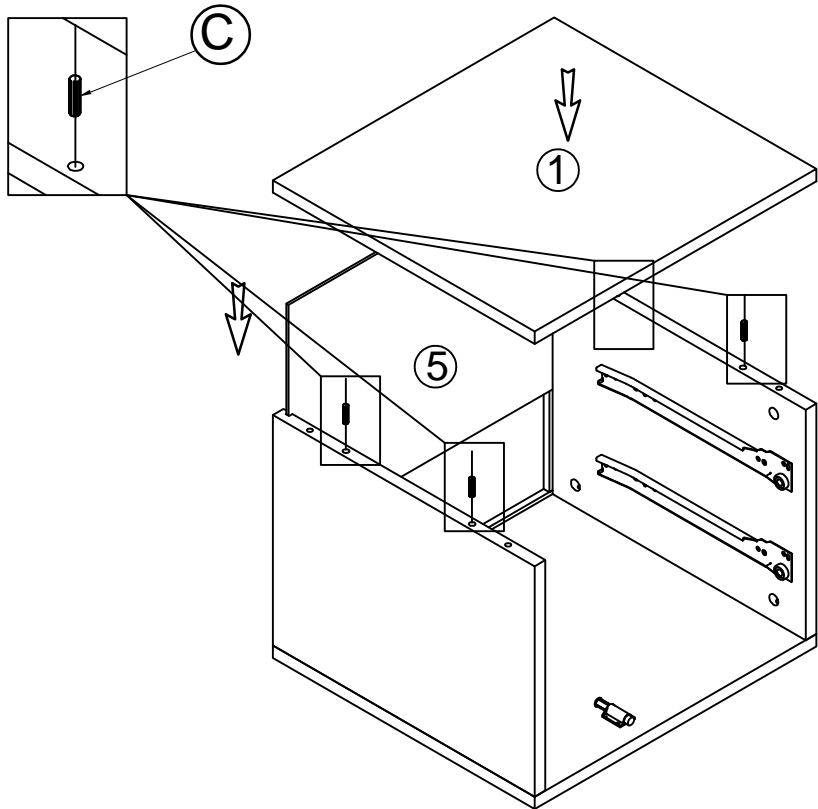

STEP 4: Following below illustration:

E



16 pcs

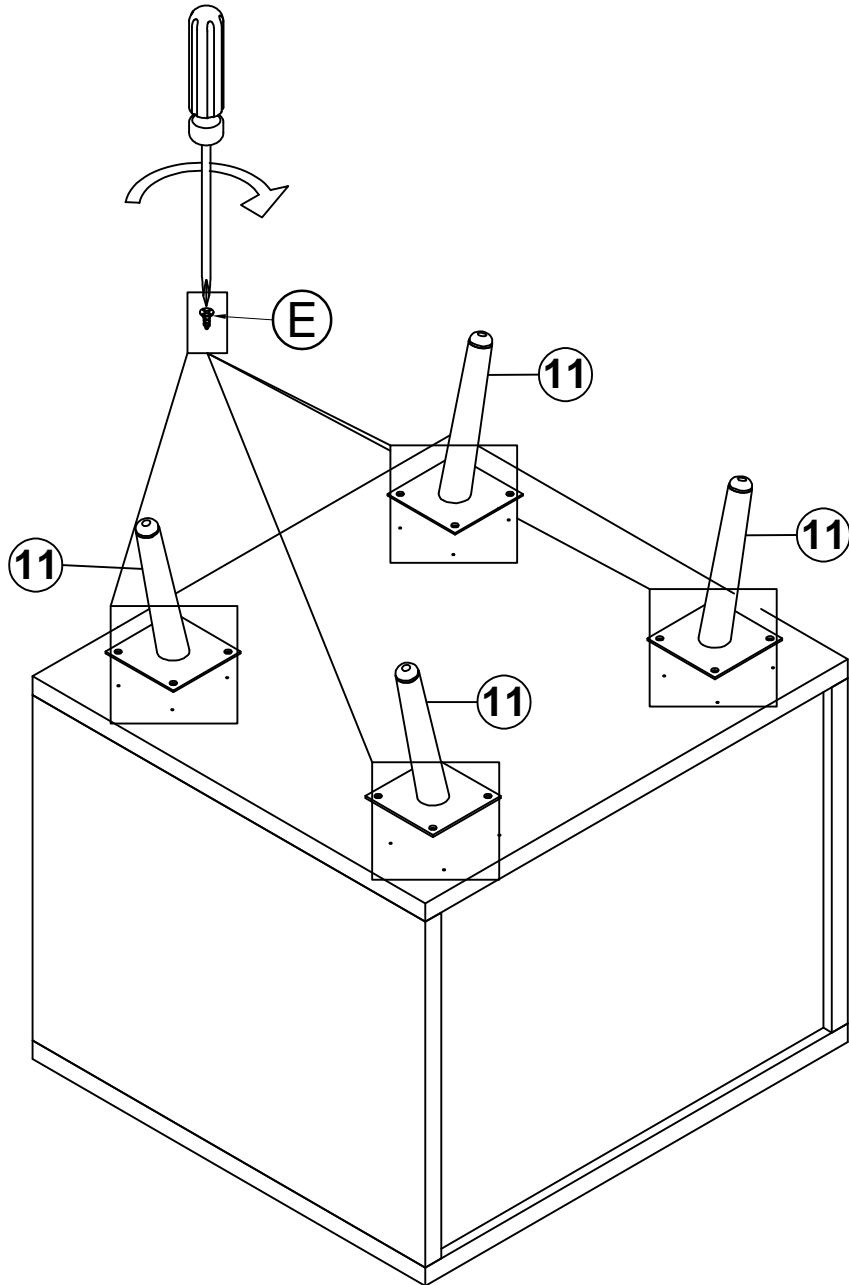

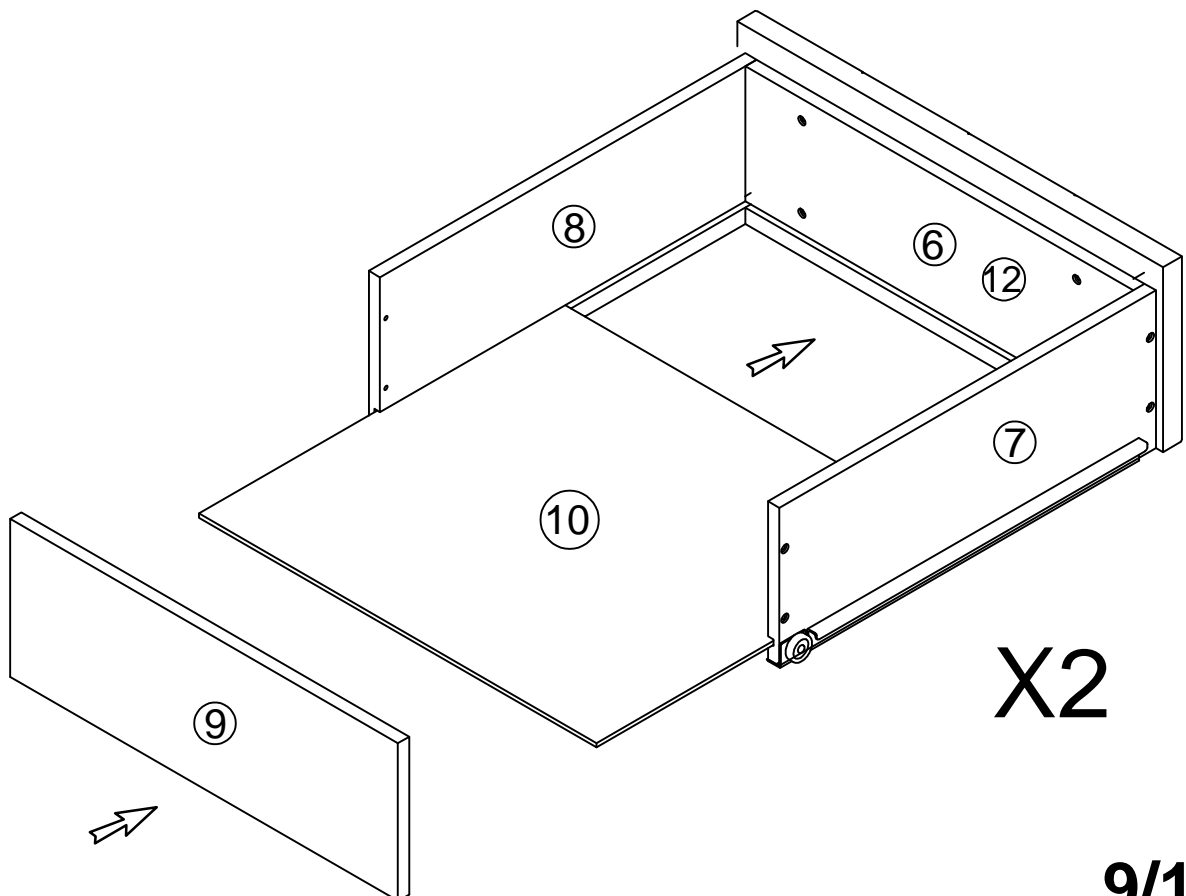
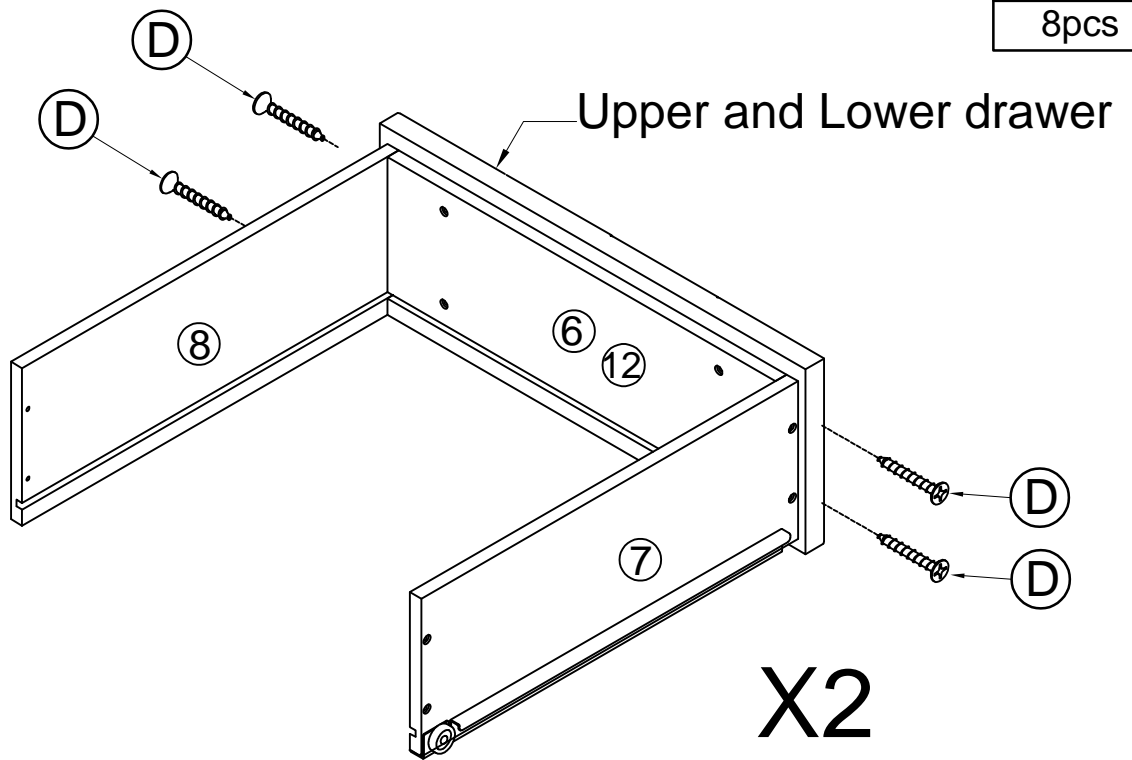

STEP 5: Following below illustration:

D	
8pcs	

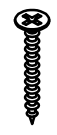

STEP 6: Following below illustration:

E		F		D	
2 pcs		2 pcs		8 pcs	

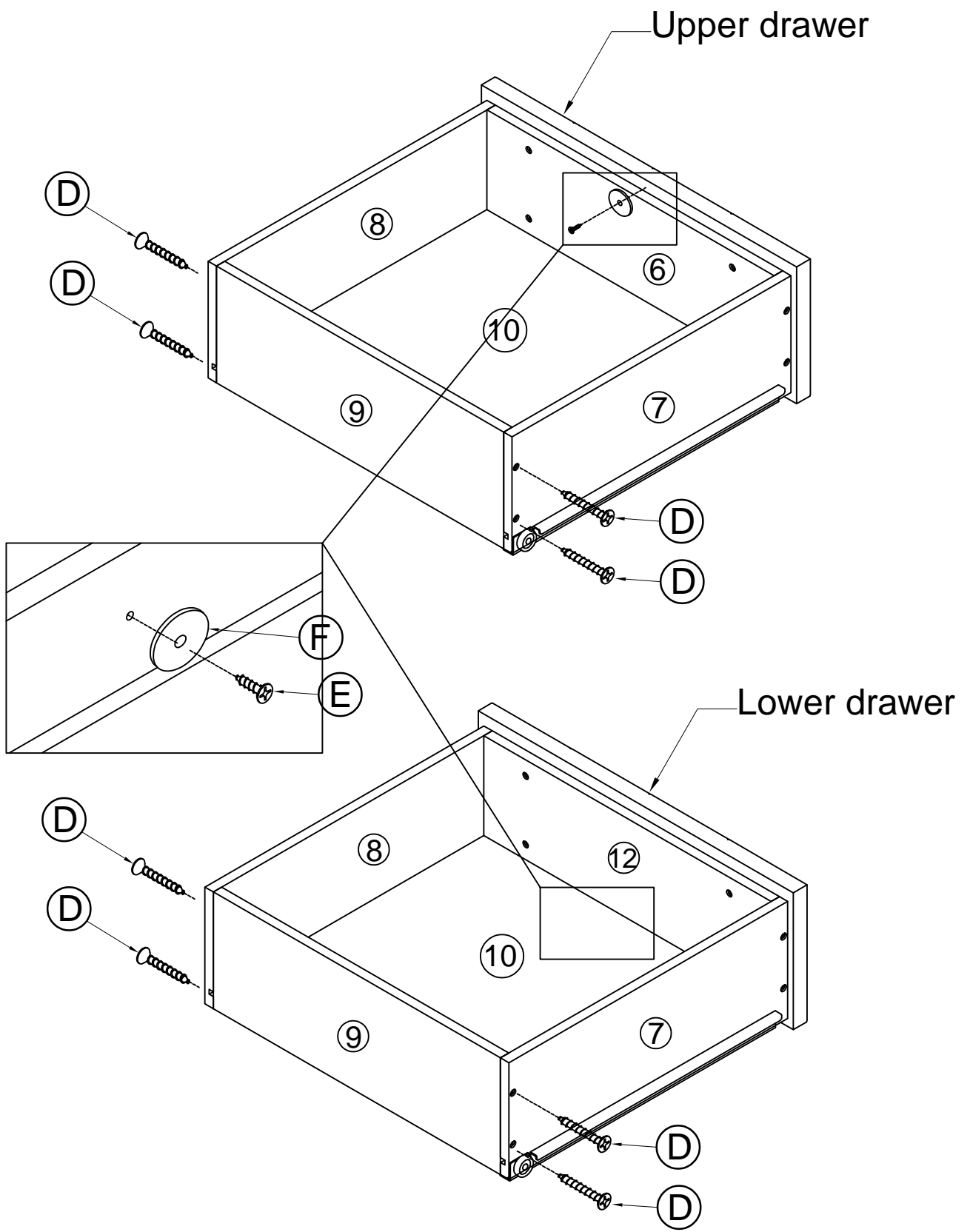

STEP 7: Following below illustration:

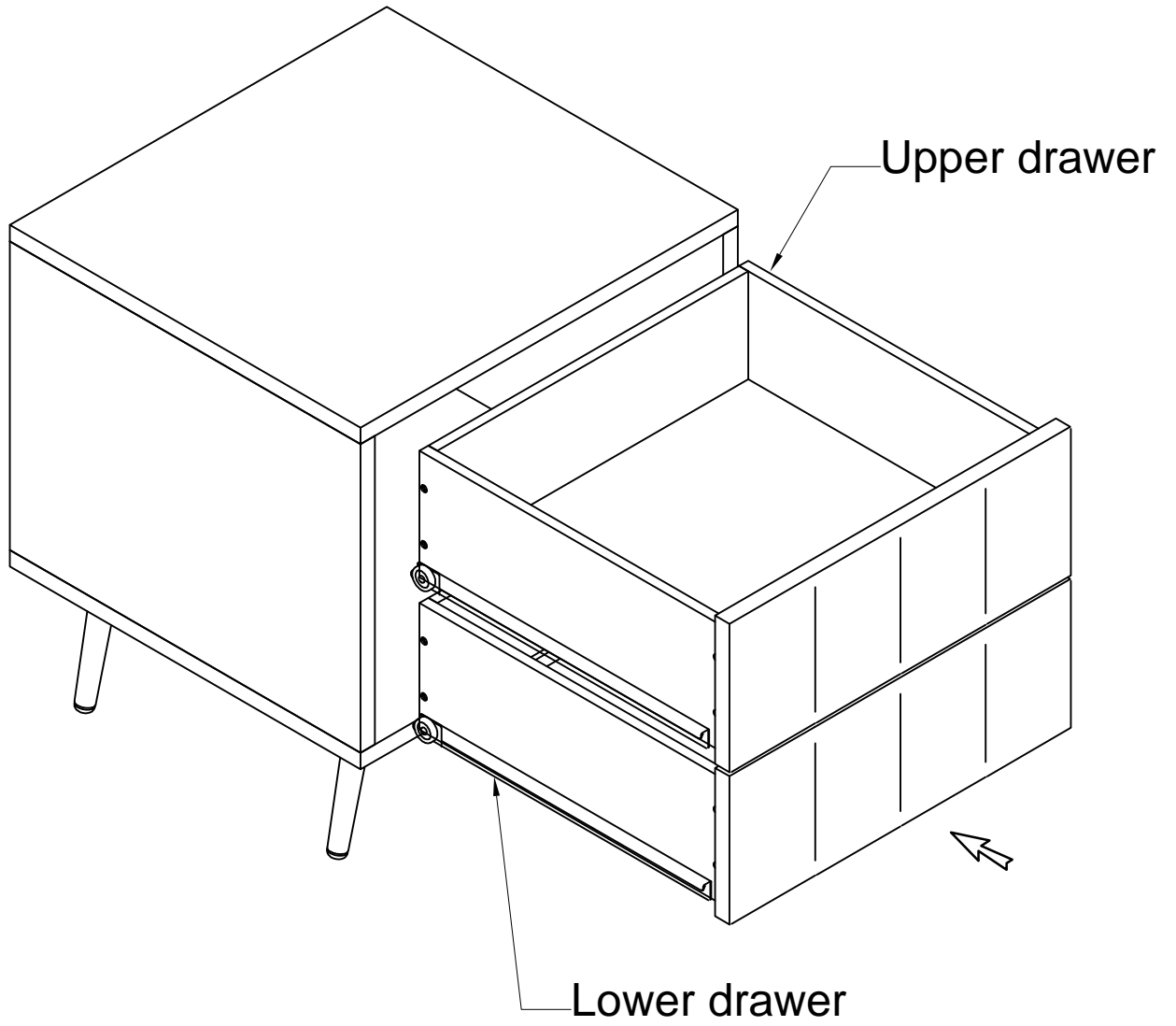

FINISH

