

ASSEMBLY INSTRUCTION

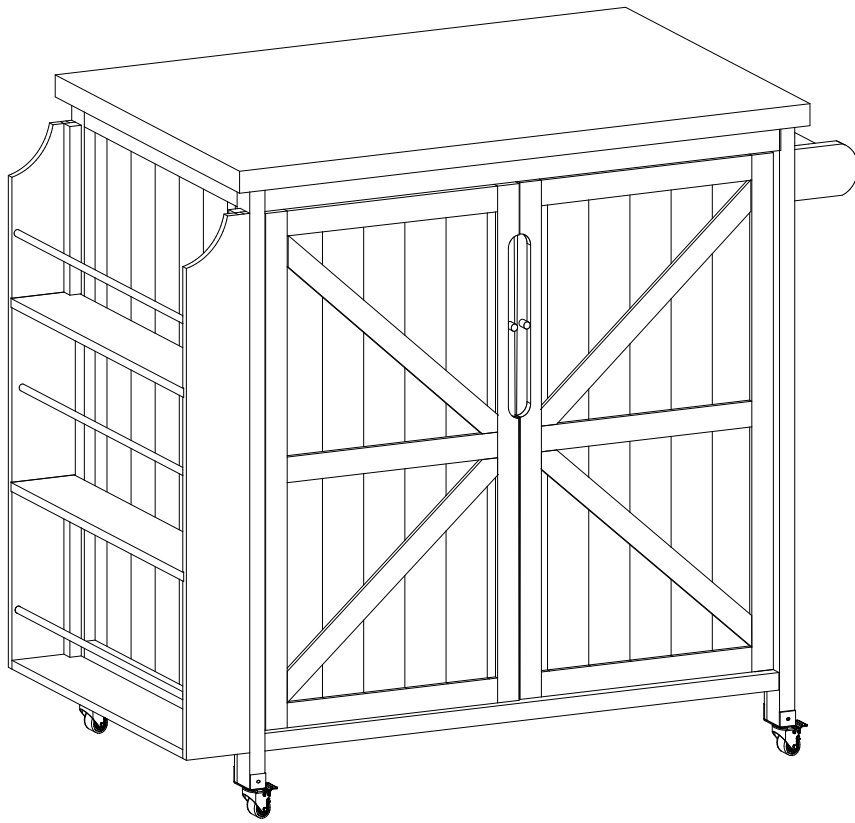







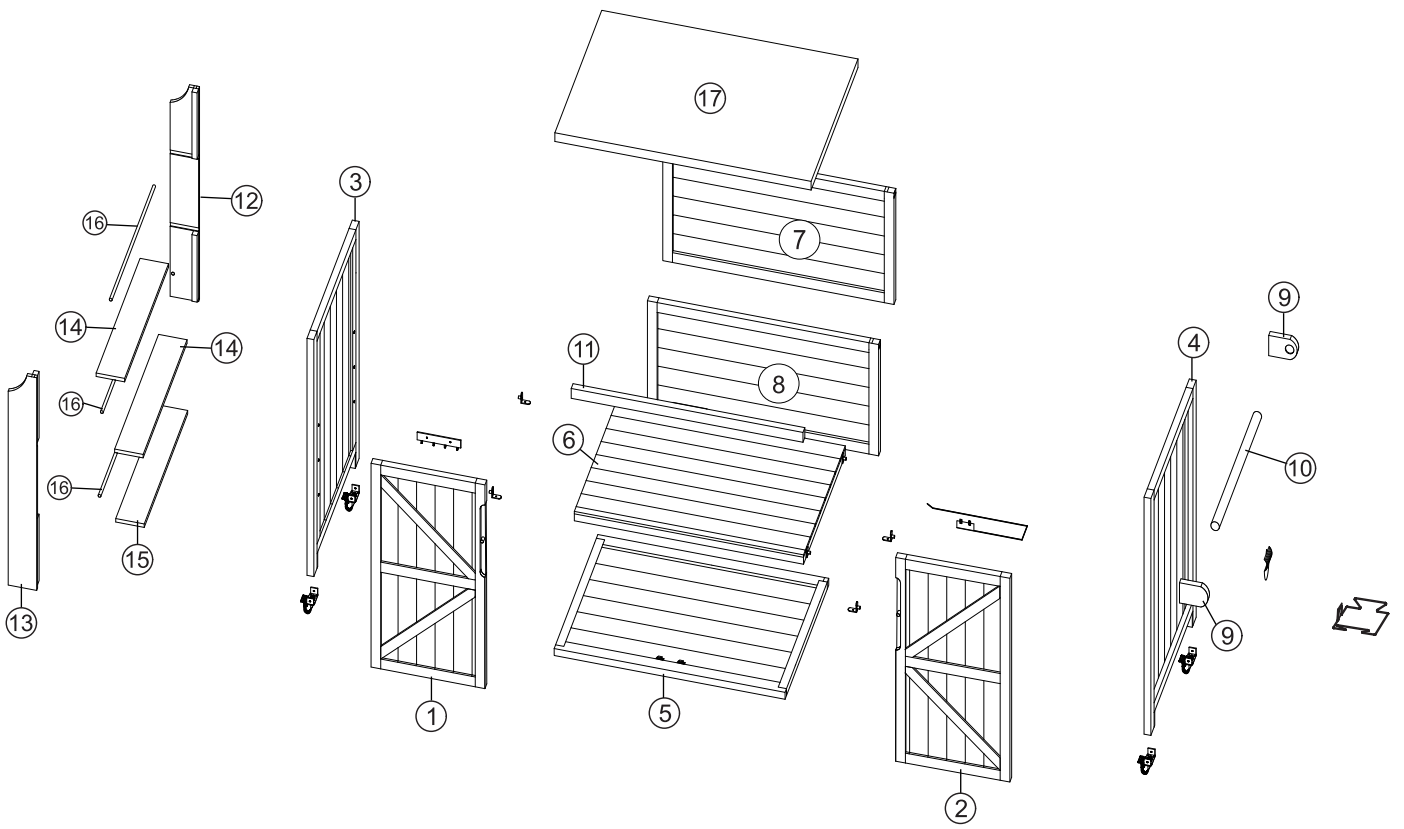

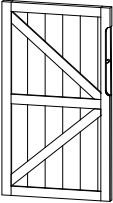
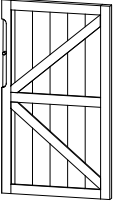
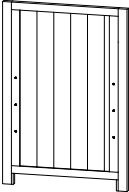
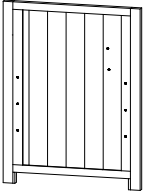
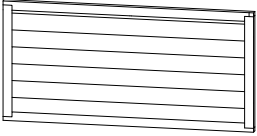
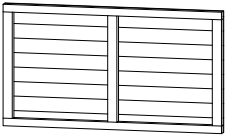
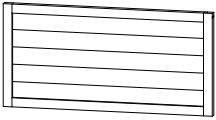

IMPORTANT NOTE:







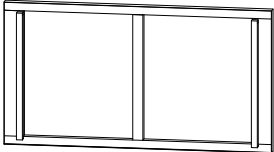







- ① PLACE ALL PARTS ON A CLEAN AND SMOOTH SURFACE SUCH AS A RUG OR CARPET TO AVOID THE PARTS FROM BEING SCRATCHED.
- ② BEFORE YOU BEGIN, KINDLY FOLLOW THE ASSEMBLY INSTRUCTIONS STEP BY STEP.
- ③ DO NOT TIGHTEN ALL SCREWS AND BOLTS UNTIL THIS ITEM IS FULLY SET-UP.

Detail View

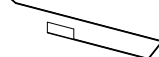

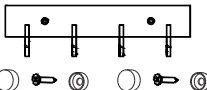
1		2		3		4	
	1x		1x		1x		1x
5		6		7		8	
	1x		2x		1x		1x
9		10		11		12	
	2x		1x		1x		2x
13		14		15		16	
	1x		2x		1x		3x
17							

Hardware List

A	 Ø3.5*45 16x	B	 Ø3.5*40 14x	C	 Ø 3.0*30 12x	D	 Ø 3.0*16 20x				
E	 Ø6.0*40 2x	F	 Ø 3.0*10 4x	G	 18x	H	 4x	I	 1x		
J	 4x	K	 1x	L	 2x	M	 2x	N	 2x	O	 4x

ASSEMBLY TOOLS REQUIRED(NOT INCLUDED)



PLEASE BE CAREFUL DO NOT DAMAGE THE HOLE POSITION WHEN YOU USE POWERTOOLS !

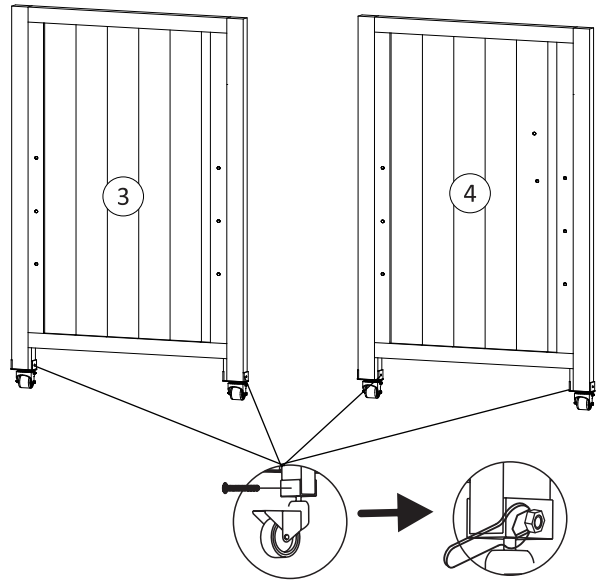
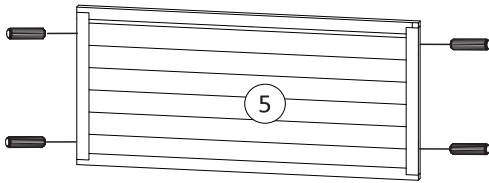
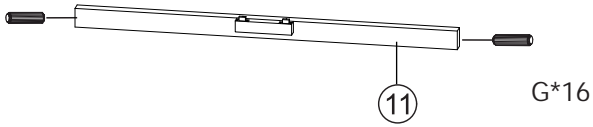
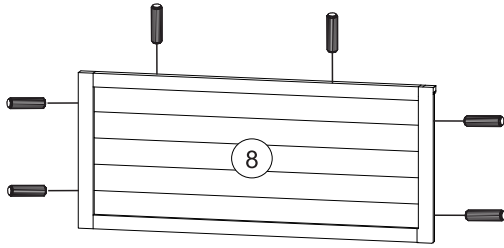
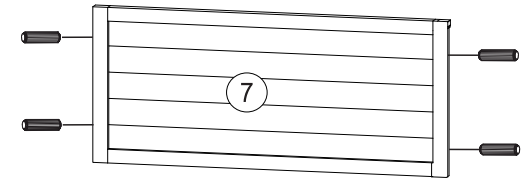

J*4

1



G*16

2



J*4

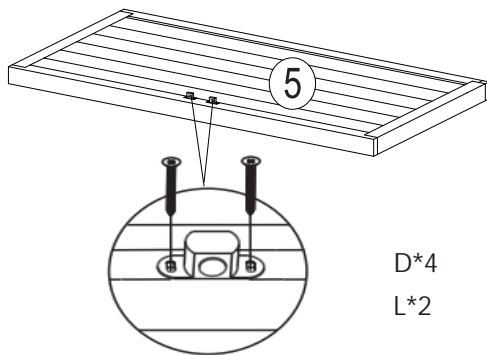

5

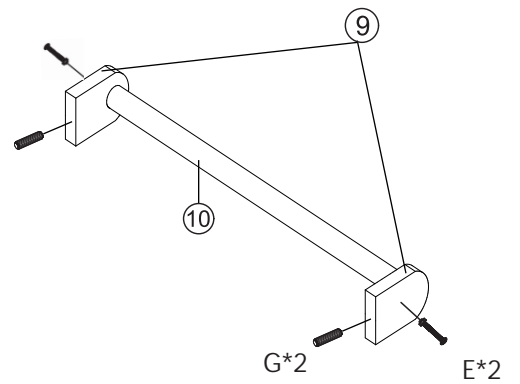

3



L*2

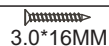

3.0*16MM

D*4

4



G*2



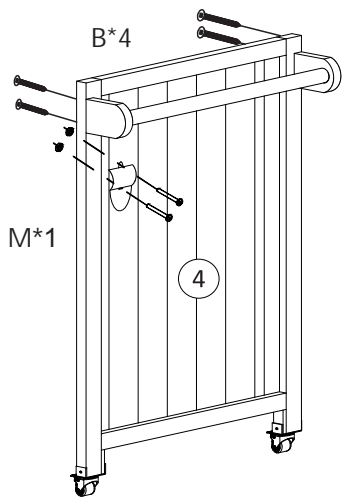

6.0*40MM

E*2



5

	
M*1	B*4



6

A*3

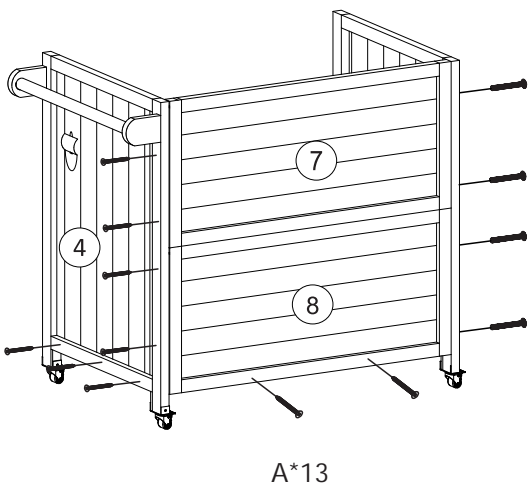

7

A*13

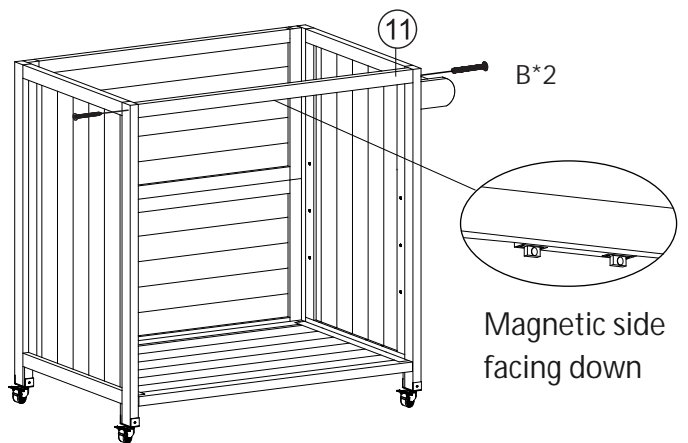



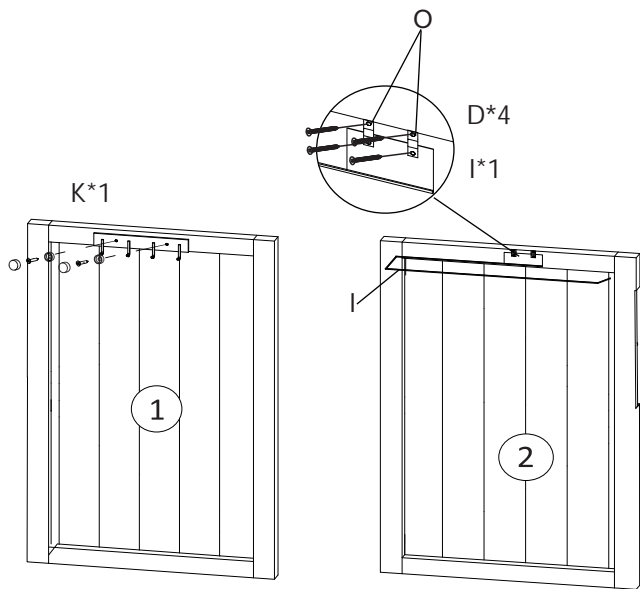

8

B*2

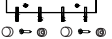

9

			
O*2	I*1	K*1	3.0*16MM D*4

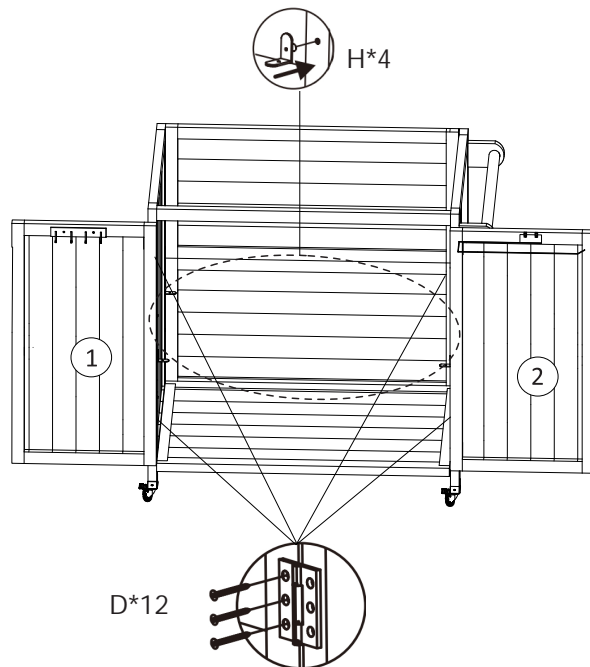

10

	
H*4	3.0*16MM D*12

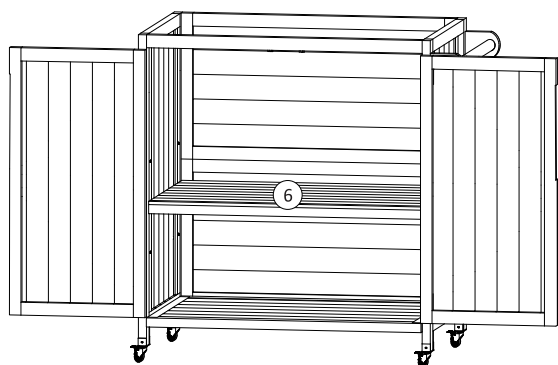

11

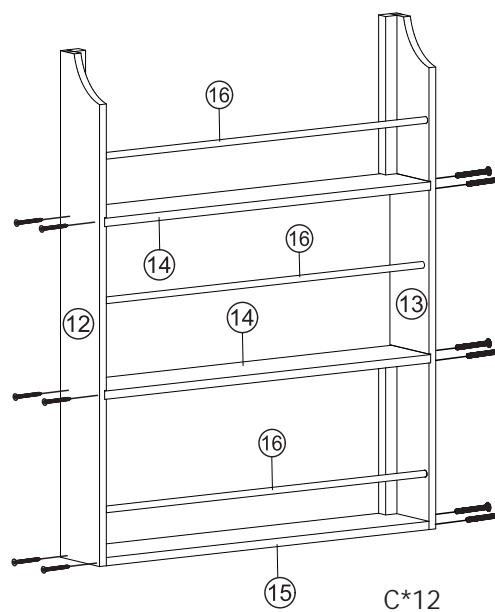

12

3.0*30MM C*12

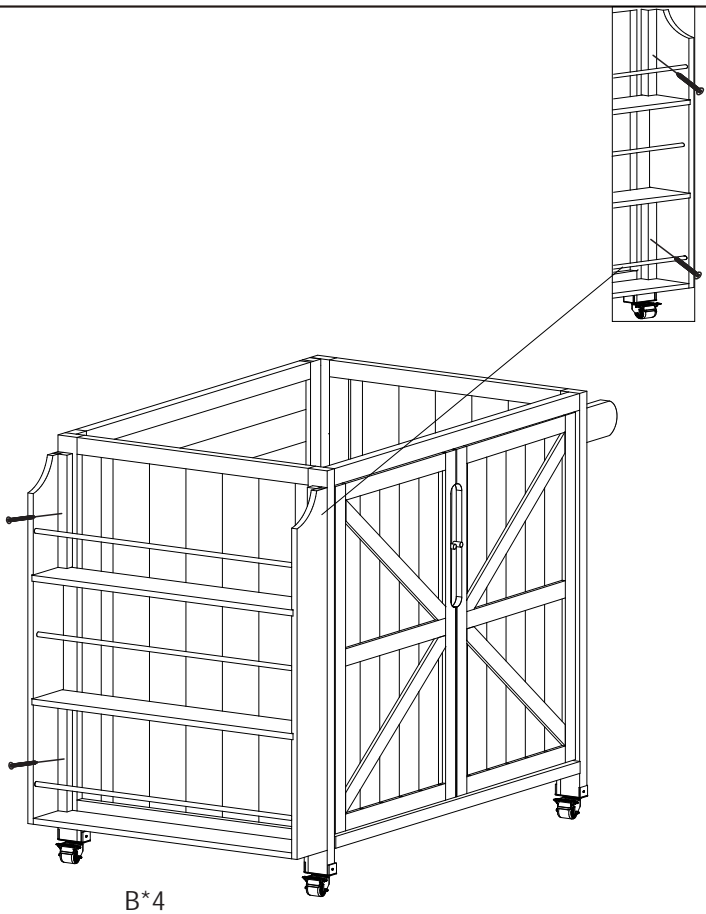

B*4

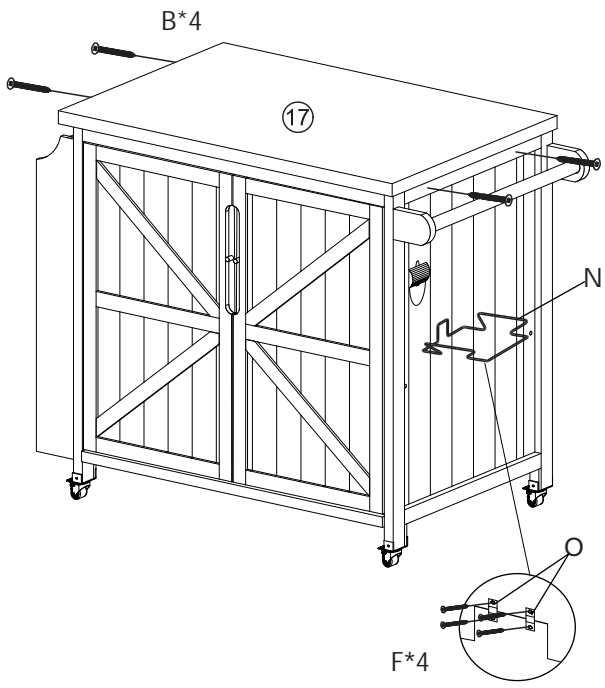

F*4

15

	3.5*40MM
	B*4

16

O*2	N*1	3.5*40MM	3.0*10MM
		B*4	F*4

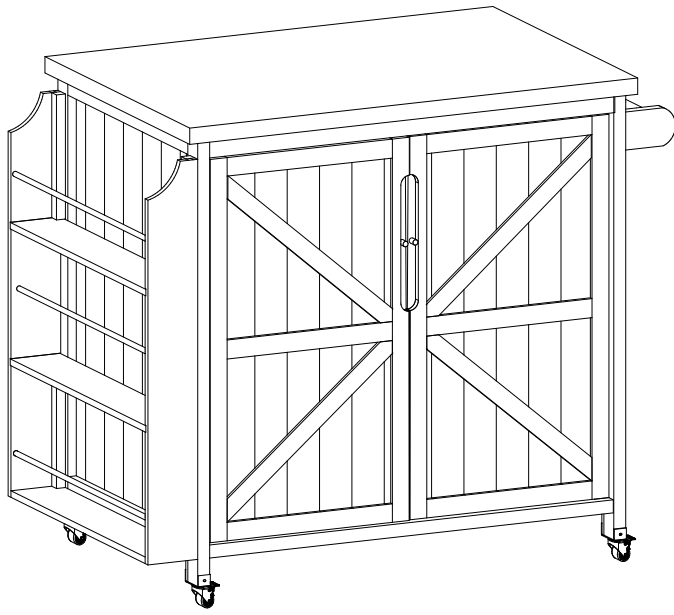

17