



42 GREENE STREET LL NEW YORK NY 10013
T 212.355.0625 F 212.355.0628 WWW.OASIQ.US



YLAND Ottoman

W 27" D 29.4" H 11"
SH 11" CH 4 1/2" OSH 15 1/2"
21 lbs
Powder coated aluminum

YLAND: FRAME



White

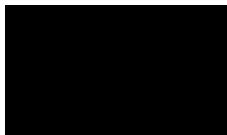

Anthracite

YLAND: CUSHION FABRICS

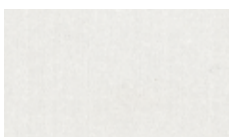

Canvas Natural



Lantern Slate

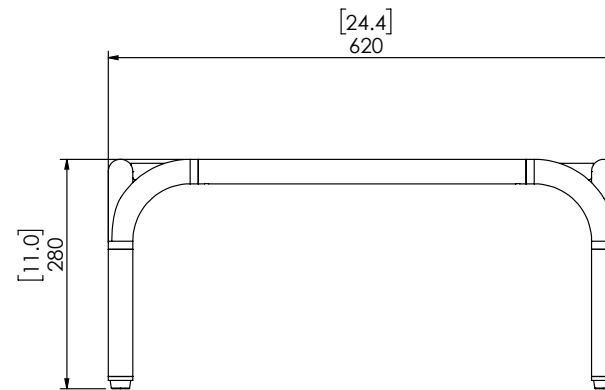
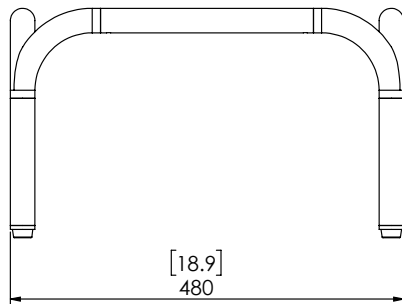
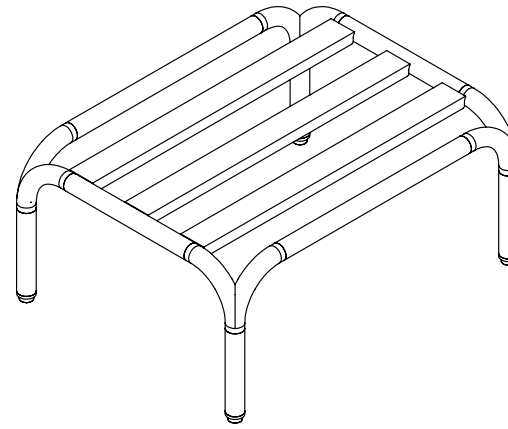
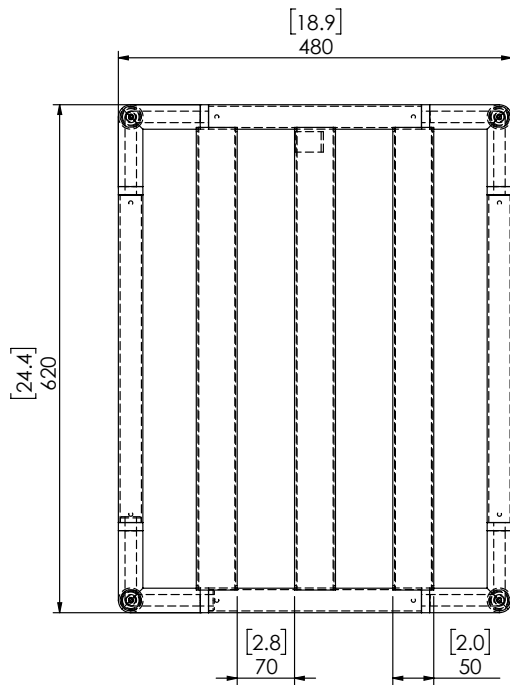

OASIQ

DWG.NO: FAEOA5-6

DIM EXT: 620X480X280mm

MATERIAL: AL

FINISH DATE: 2019-6-12
DRAWN BY: Mr. ADA

SCALE : 1:1

P. 2