

**IMPORTANT!! PLEASE READ ENTIRE INSTRUCTION SHEET BEFORE ASSEMBLY!!**

**5pcs Sling Set--Sling Chair**







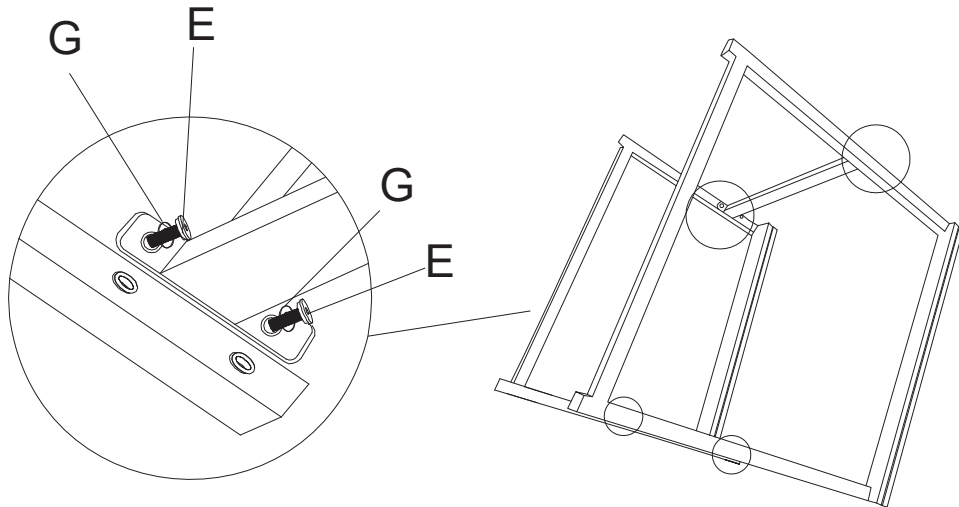

Identify all parts packed in the carton against the parts list. Remove all protective materials. Place parts on a non-abrasive surface. If you are missing any parts or Are unsure how to proceed with assembly, please call customer service center

Do not attempt to assemble the product if any parts are missing or damaged.

**Step 1**

Place the Chair Arms (A & B) Support Bar (D) on a flat soft surface. Attach the two Support Bars (D) to the Chair Arms(A&B) by using bolt (E) with the metal washers (G). (DO NOT TIGHTEN COMPLETELY)



Parts List							
A	Right Chair Arm		4	B	Left Chair Arm		4
C	Seat & Back Bracket		4	D	Support Bars		8
E	Bolt(M6*20)		32	F	Bolt(M6*30)		16
G	Metal Washer		48	H	Allen Wrench		1

**Step 2**

Attach the Seat & Back Bracket (C) to the Chair Arms(A&B) with Bolt(F)with the metal washers (G).

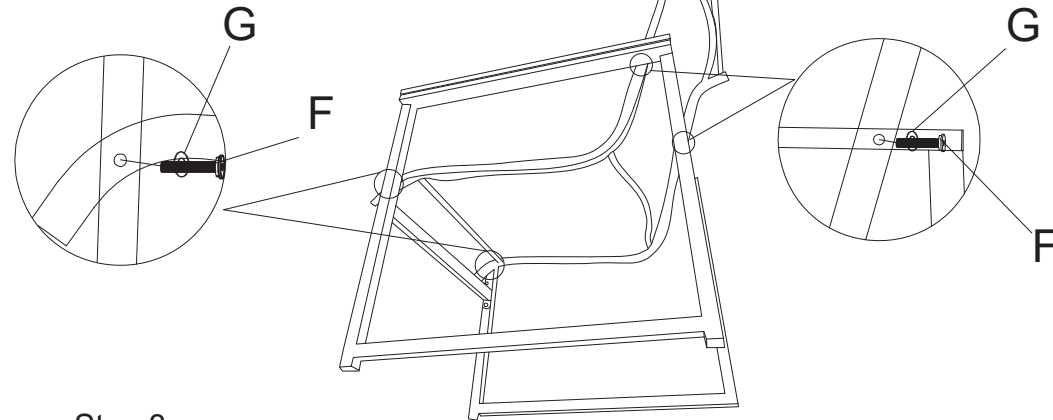

**Step 3**

Tighten all bolts (E&F) by using Allen wrench (J). Carefully turn the chair in the upright position.

Your chair is now ready for use.

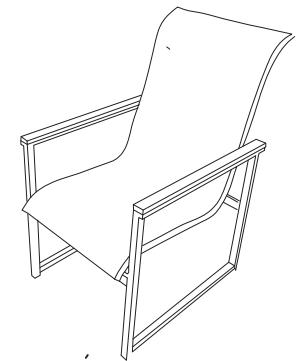

**IMPORTANT!! PLEASE READ ENTIRE INSTRUCTION SHEET BEFORE ASSEMBLY!!**

**5pcs Sling Set- Dining Table**





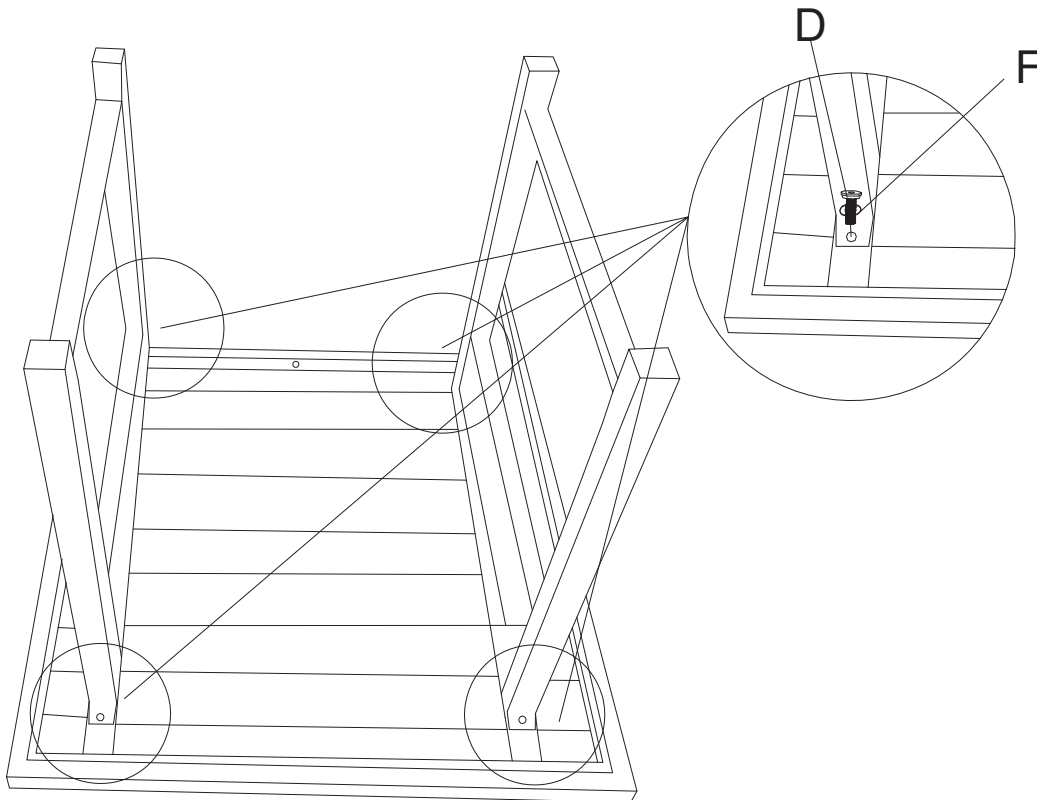

Identify all parts packed in the carton against the parts list. Remove all protective materials. Place parts on a non-abrasive surface. If you are missing any parts or Are unsure how to proceed with assembly, please call customer service center

Do not attempt to assemble the product if any parts are missing or damaged.

**Step 1**

Place the Table Top(A) upside down on a flat soft surface. Attach Table Leg (C) to Table Top (A) by using Bolt(D) with the metal washers (F). (DO NOT TIGHTEN COMPLETELY)



Parts List							
A	Table top		1	B	Table Side Skirt		2
C	Table Leg		2	D	Bolt(M6*15)		4
E	Bolt(M6*25)		8	F	Metal Washer		12
G	Allen Wrench		1				

**Step 2**

Attach the Table Side Skirt (B) to Table Leg (C) by using Bolts (E) with the metal washer (F).

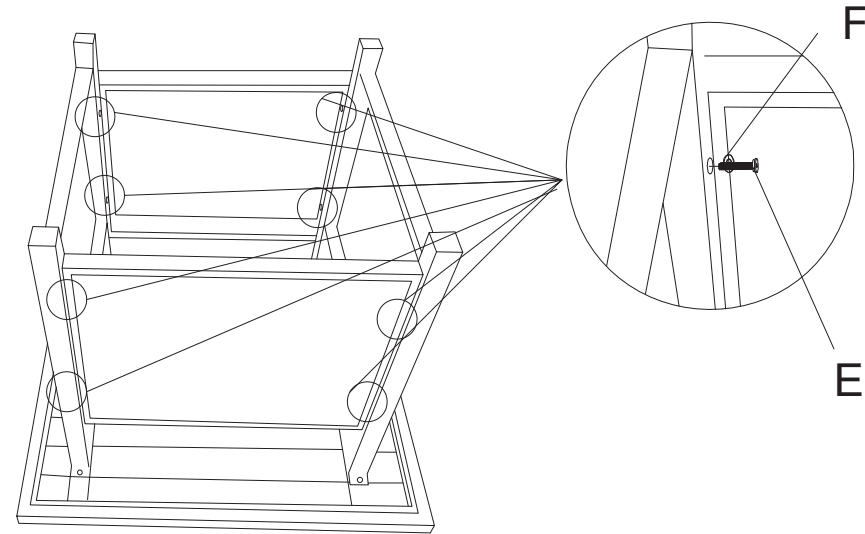

**Step 3**

Tighten all the bolts completely by using Allen Wrench (G), Turn the table in the upright position . Now the table is ready for your enjoyment.

