

MURPHY BED WITH TOP FENCE
LIT MURPHY AVEC CLÔTURE SUPÉRIEURE

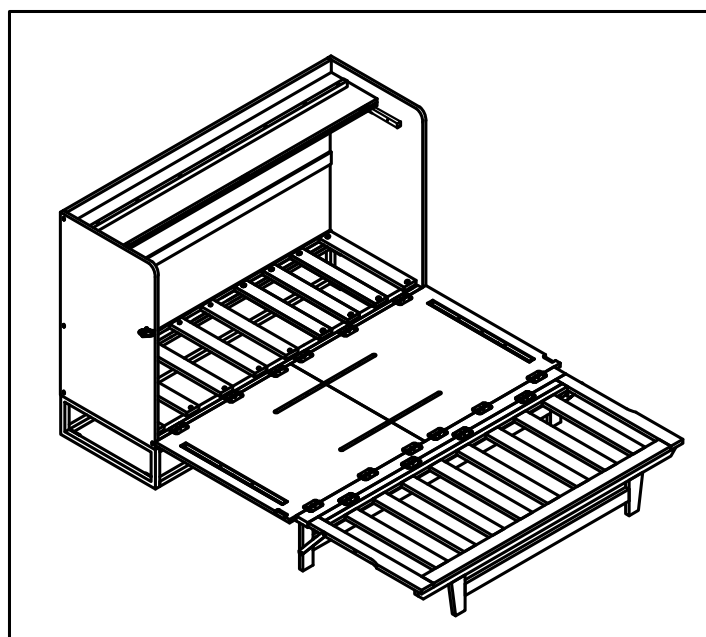

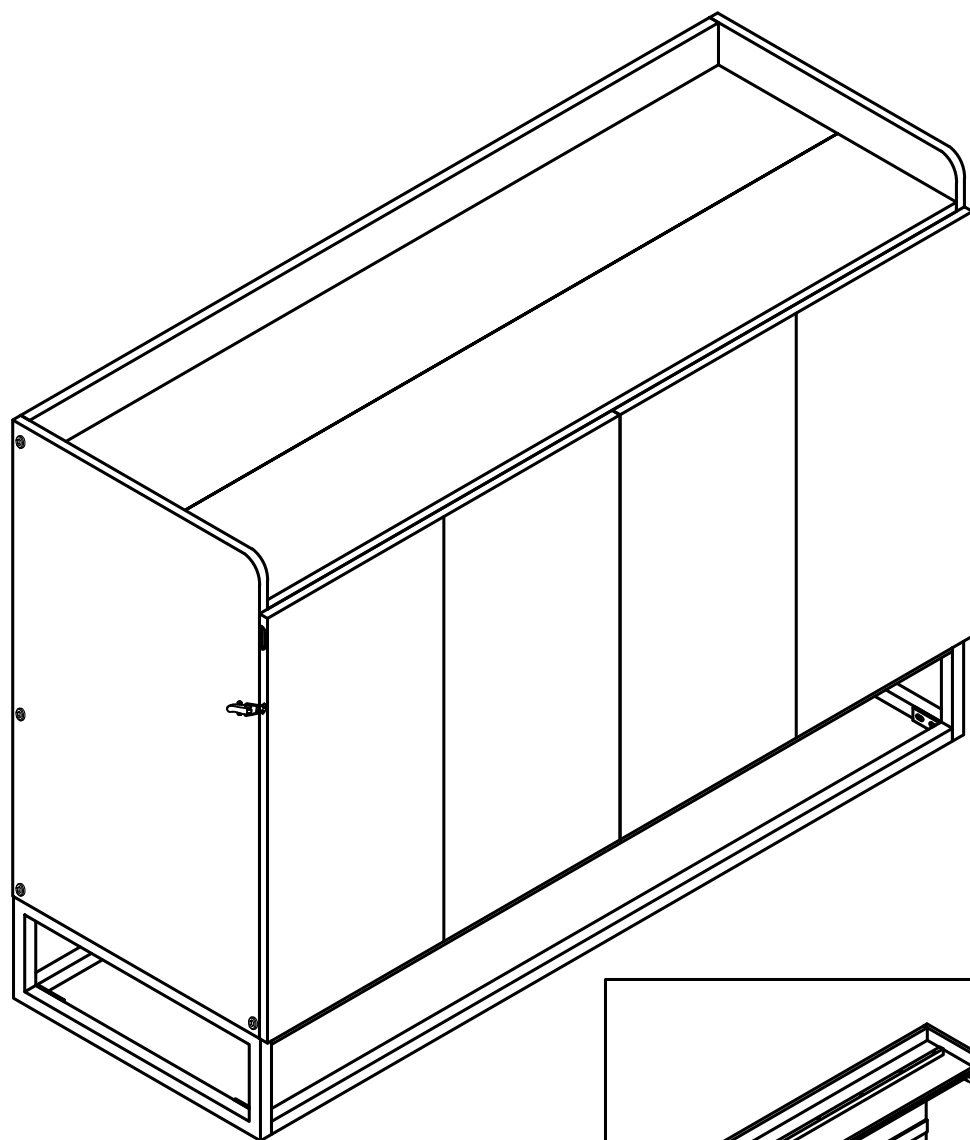

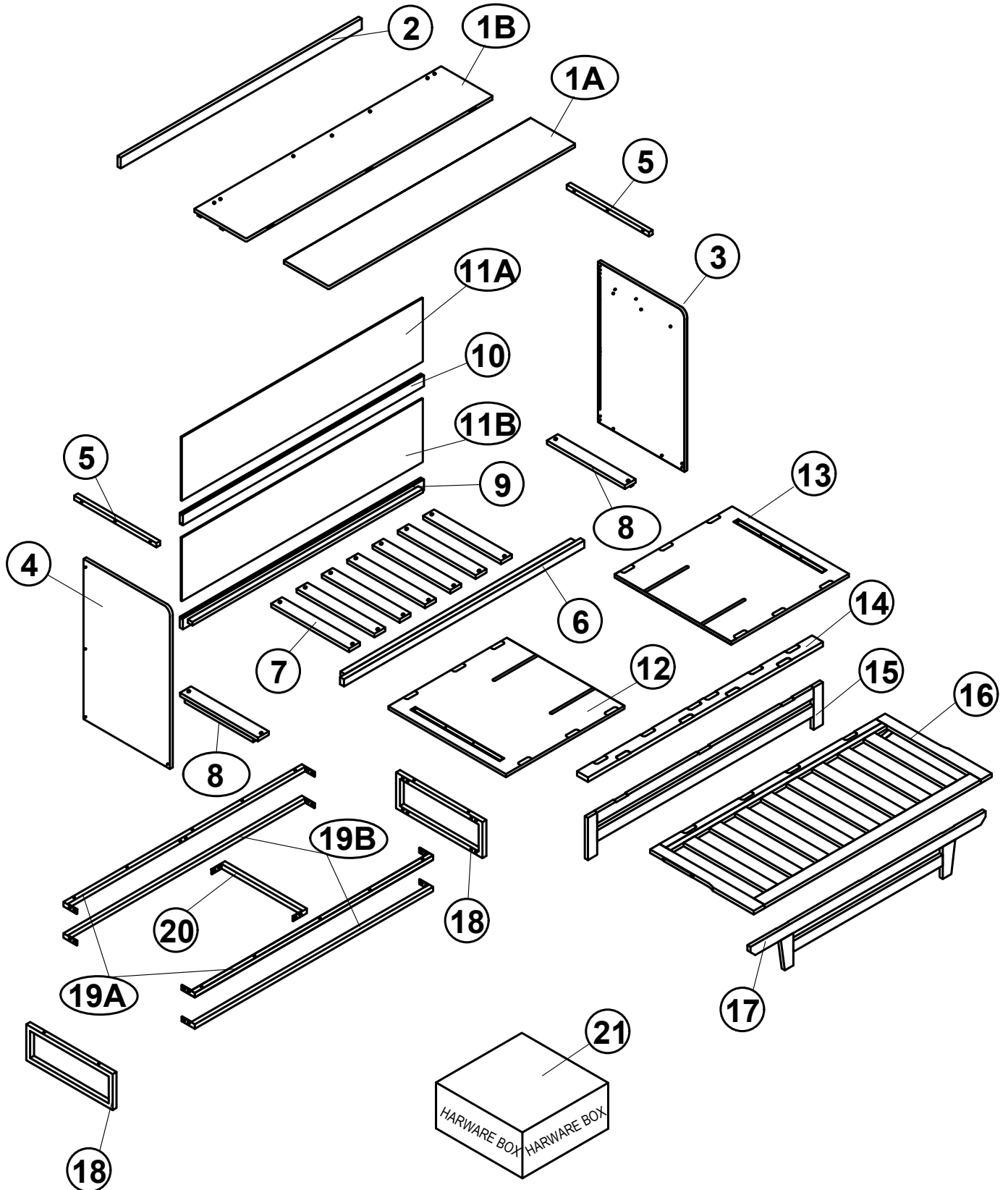



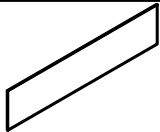

PRODUCT DETAILS

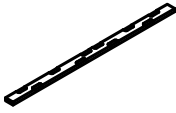

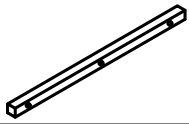
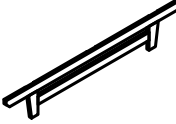
DESTAILS DU PRODUIT

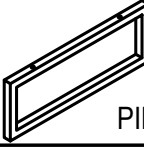
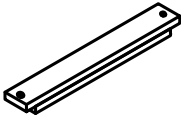
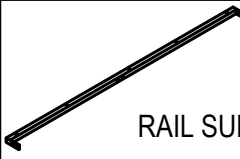
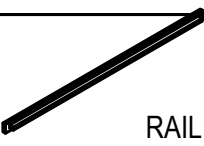
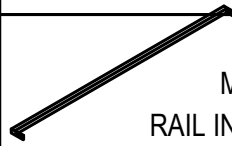
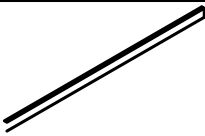
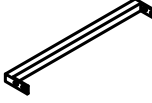
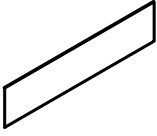

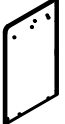

PARTS LIST (BOX 1 OF 3)
LISTE DES PIÈCES (ENCADRÉ 1 DE 3)

1A		FRONT TOP PANEL PANNEAU SUPÉRIEUR AVANT	1PC	11B		BACK PANEL PANNEAU ARRIÈRE	1PC
1B		BACK TOP PANEL PANNEAU SUPÉRIEUR ARRIÈRE	1PC	12		MIDDLE SUPPORT SOUTIEN MOYEN	1PC
2		TOP RAIL RAIL SUPÉRIEUR	1PC	13		MIDDLE LEG FRAME PIED DU CADRE MILIEU	1PC
5		SUPPORT RAIL RAIL DE SUPPORT	2PCS	17		FRONT LEG FRAME PIED DU CADRE AVANT	1PC
6		FRONT RAIL RAIL AVANT	1PC	18		METAL SIDE LEGS PIEDS LATÉRAUX EN MÉTAL	2PCS
8		SLAT ÉTAGÈRE À LATTES	2PCS	19A		METAL TOP RAIL RAIL SUPÉRIEUR EN MÉTAL	2PCS
9		BOTTOM BACK RAIL RAIL INFÉRIEUR ARRIÈRE	1PC	19B		METAL BOTTOM RAIL RAIL INFÉRIEUR EN MÉTAL	2PCS
10		MIDDLE BACK RAIL RAIL ARRIÈRE MILIEU	1PC	20		METAL CENTER RAIL RAIL CENTRAL EN MÉTAL	1PC
11A		BACK PANEL PANNEAU ARRIÈRE	1PC	21		HARWARE BOX BOÎTE DE MATÉRIEL	1PC

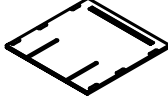













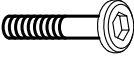



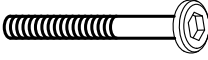

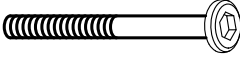





PARTS LIST (BOX 2 OF 3)
LISTE DES PIÈCES (ENCADRÉ 2 DE 3)

3	 <p>LEFT SIDE PANEL PANNEAU LATÉRAL GAUCHE</p>	1PC	12	 <p>LEFT DOOR PANEL PANNEAU DE PORTE GAUCHE</p>	1PC
4	 <p>RIGHT SIDE PANEL PANNEAU LATÉRAL DROIT</p>	1PC	13	 <p>RIGHT DOOR PANEL PANNEAU DE PORTE DROIT</p>	1PC

PARTS LIST (BOX 3 OF 3)
LISTE DES PIÈCES (ENCADRÉ 3 DE 3)

7	 <p>SLATS ÉTAGÈRE À LATTES</p>	7PCS	16	 <p>FRONT SUPPORT FRAME SUPPORT DE CADRE AVANT</p>	1PC
---	---	------	----	--	-----

HARDWA LISTE DU MATÉRIEL

A		8x30mm	25PCS	N		3.5x15mm	140PCS
B		M6x15mm	20PCS	O		4x15mm	16PCS
C		M6x30mm	16PCS	P		4x30mm	18PCS
D		M6x35mm	14PCS	Q			4PCS
E		M6x50mm	4PCS	R		75mm	22PCS
F		M6x60mm	6PCS	S			2PCS
G		M6x13mm	6PCS	T			2PCS
H1			4PCS	U		M6	4PCS
H2		3x12mm	8PCS	V			2PCS
I		L4	2PCS	W		6x35mm	2PCS
K			2PCS	X			3PCS
L			1PC	Y		3.5x20mm	12PCS
M			1PC	Z		4x15mm	16PCS

ASSEMBLY TOOLS REQUIRED (NOT INCLUDED)
OUTILS D'ASSEMBLAGE REQUIS (NOT INCLUS)



step 1:
étape 1:

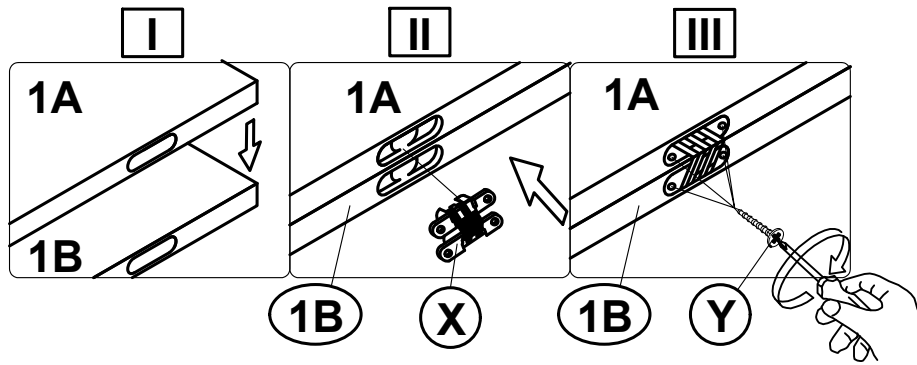
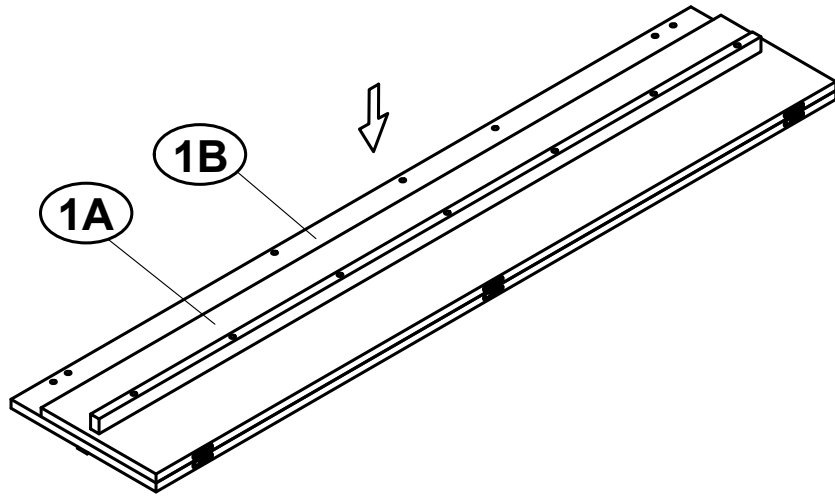

X		3PCS	Y		3.5x20mm 12PCS
---	--	------	---	--	----------------

step 2:
étape 2:

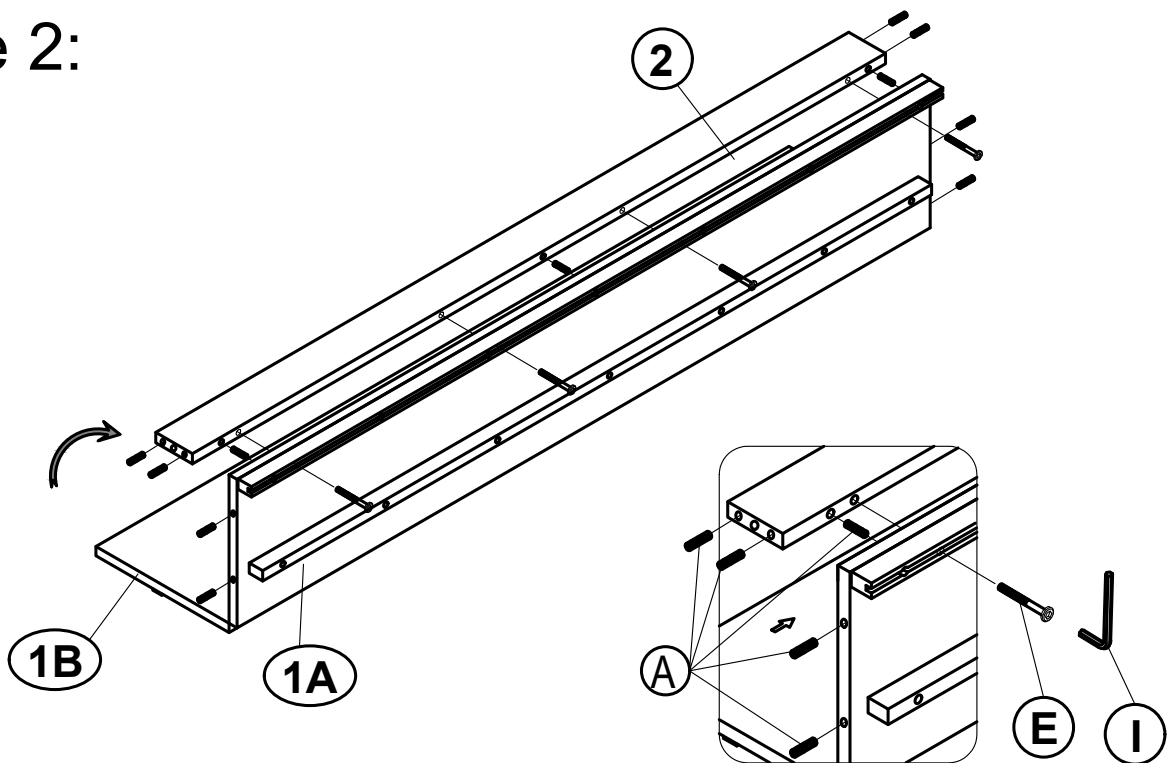

E		M6x50mm	4PCS	A		8x30mm	11PCS
I		L4	1PC				

step 3:
 étape 3:

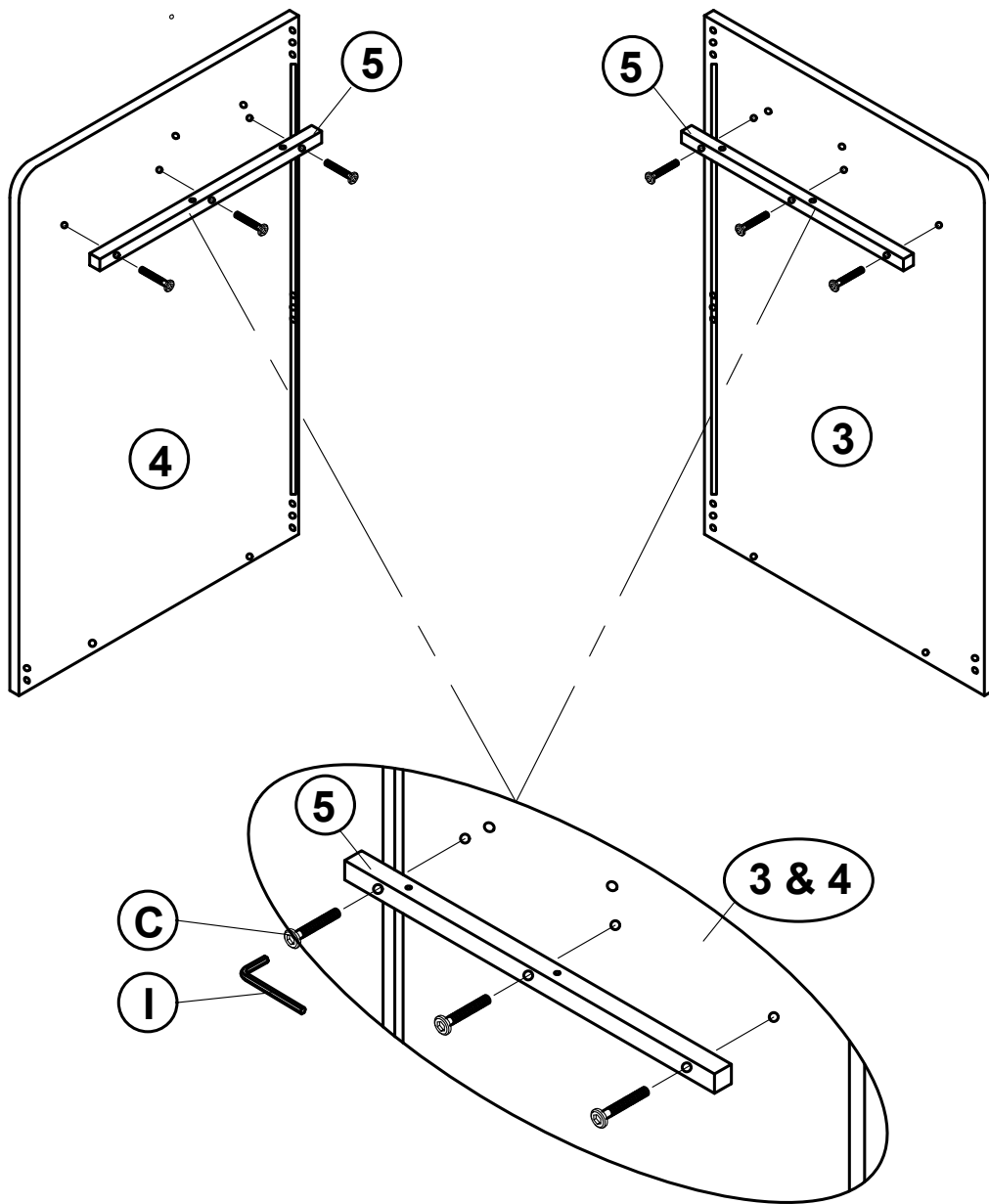

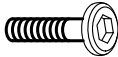

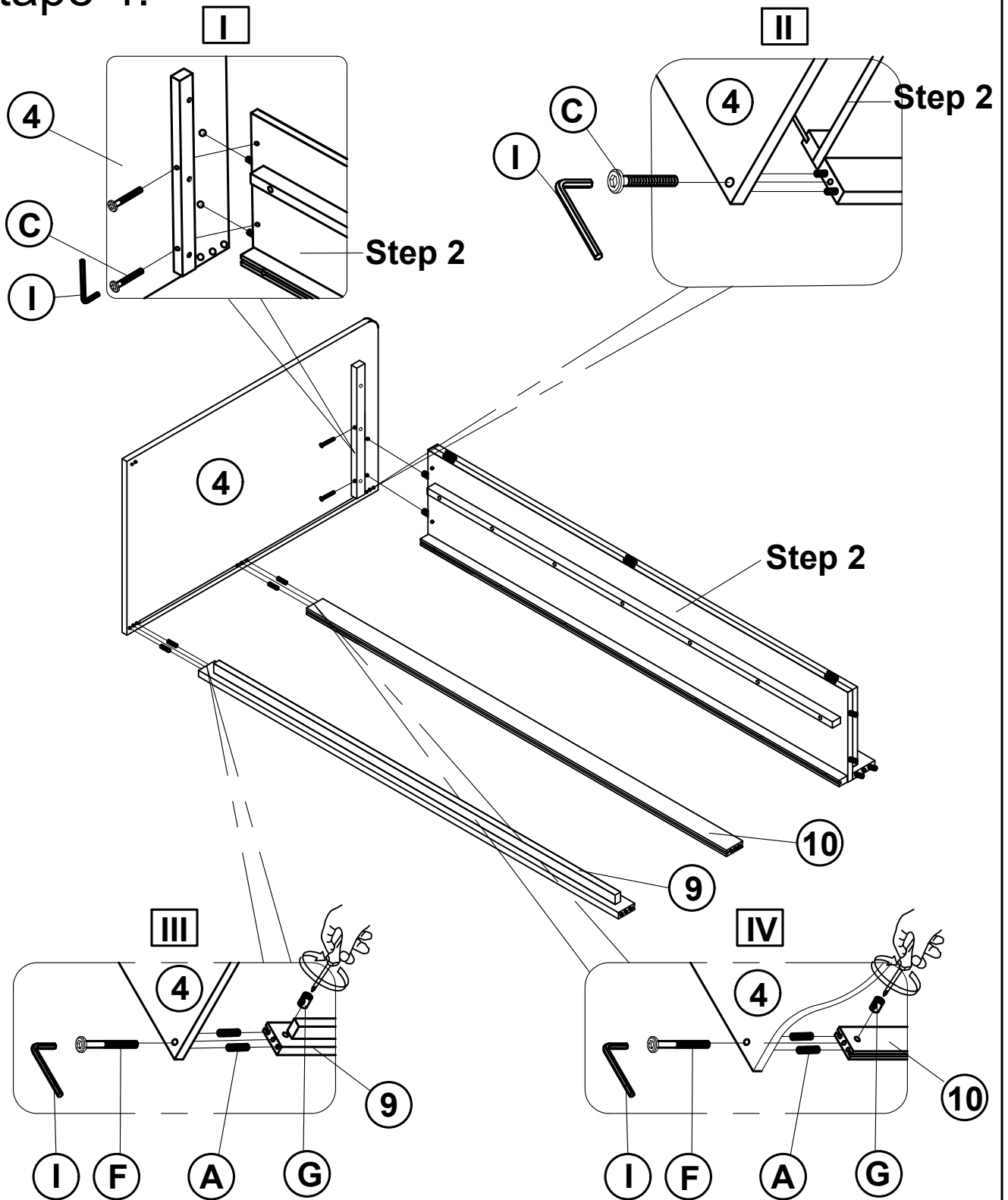

I		L4	1PC	C		M6x30mm	6PCS
---	---	----	-----	---	---	---------	------

step 4:
étape 4:

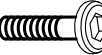

View outside / Vue extérieure

A		8x30mm	4PCS
I		L4	1PC
C		M6x30mm	3PCS

F		M6x60mm	2PCS
G		M6x13mm	2PCS

step 5:
étape 5:

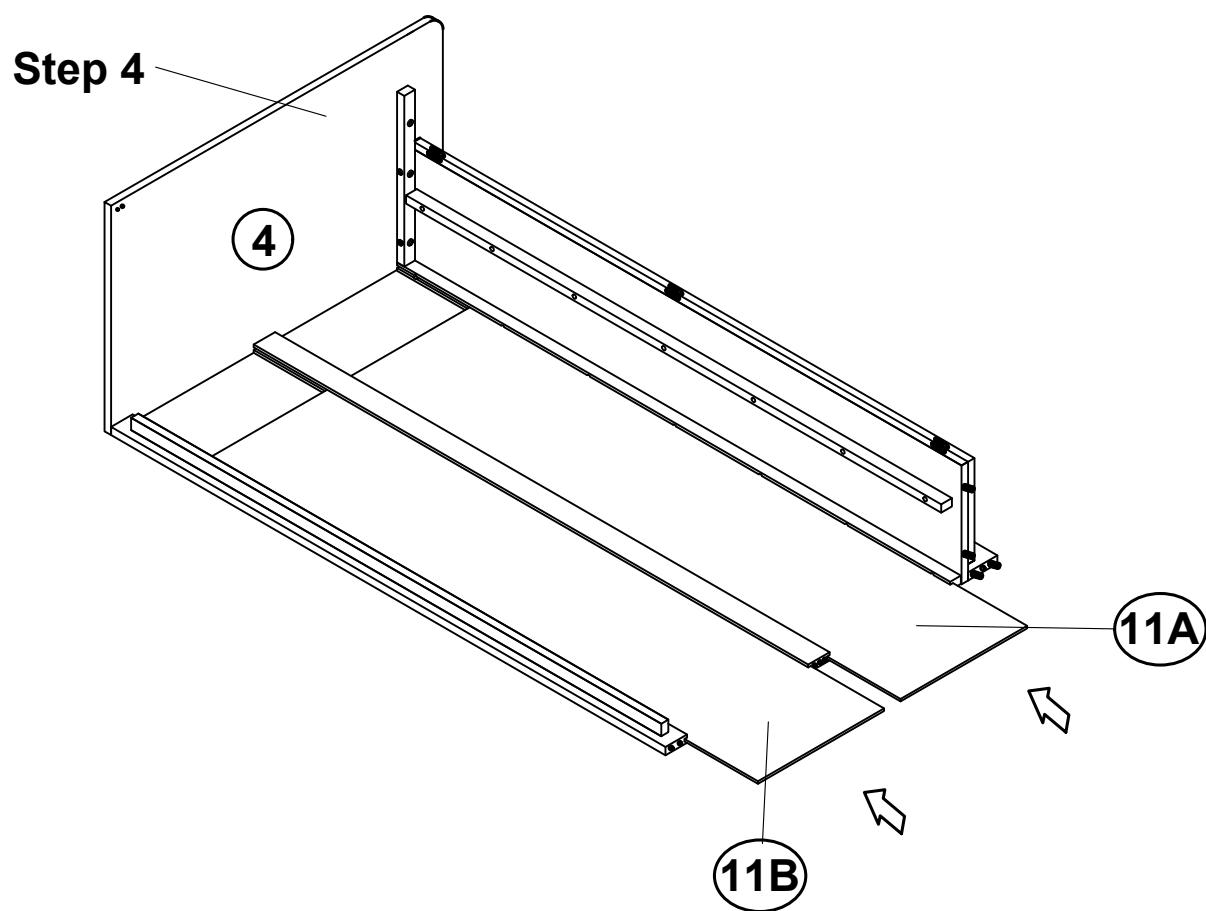

step 6:
étape 6:

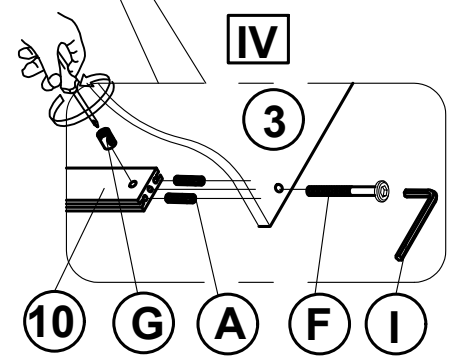
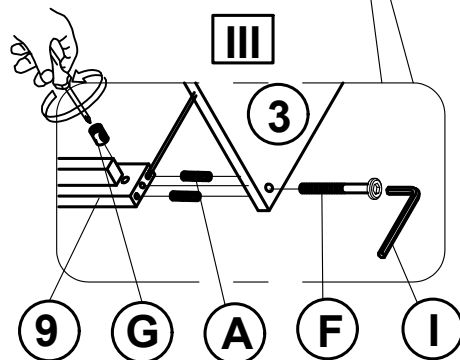
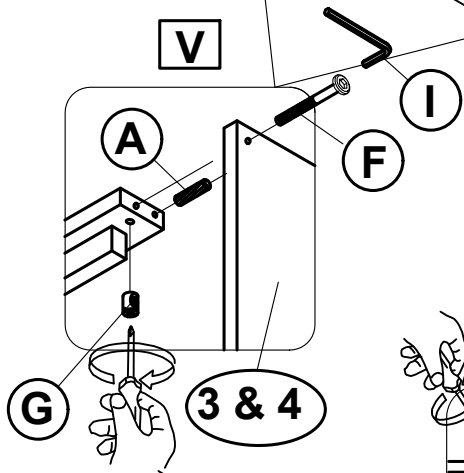
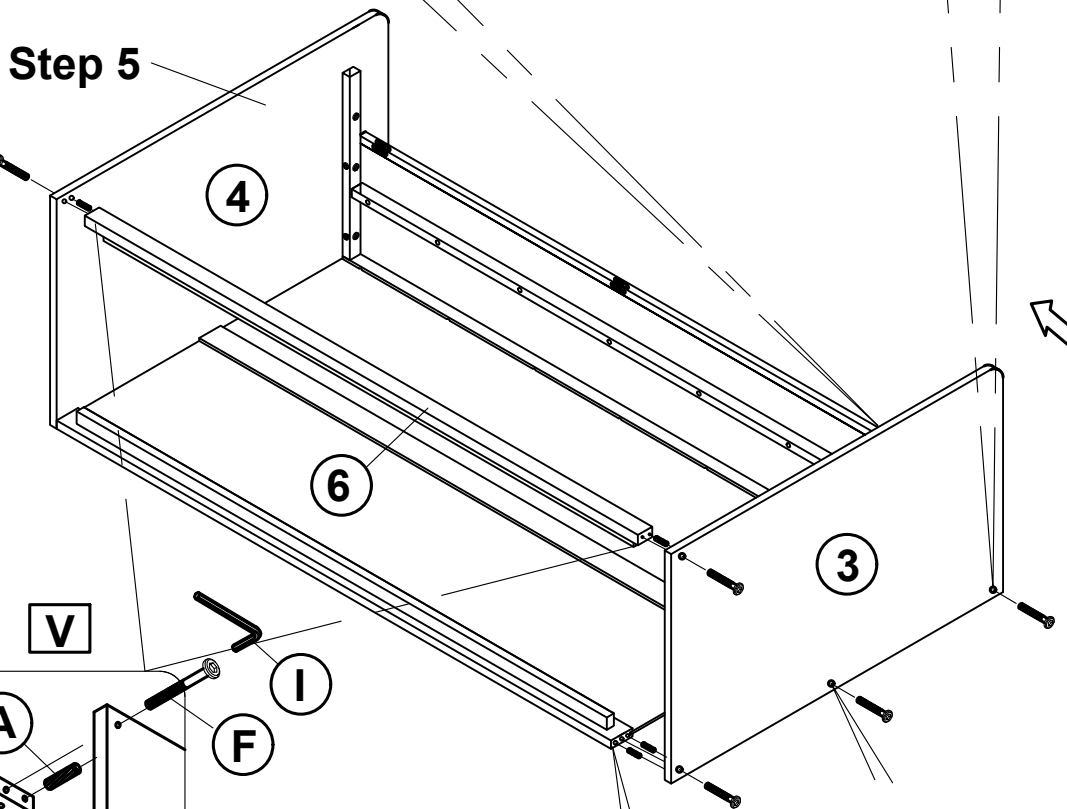
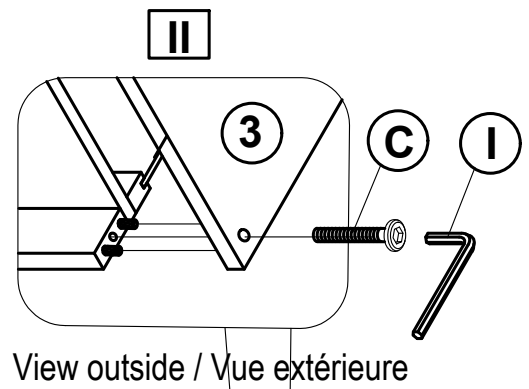
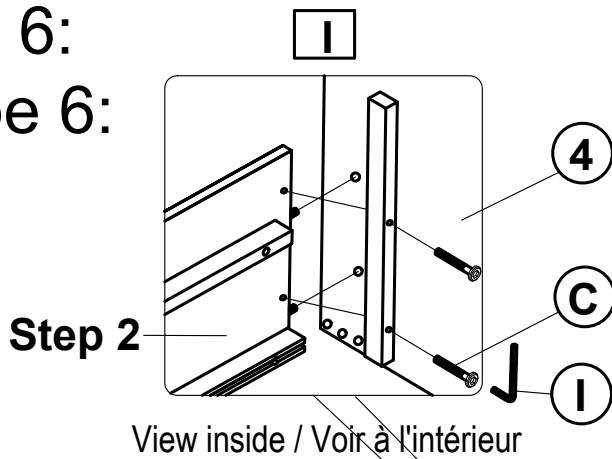

A		8x30mm	6PCS
C		M6x30mm	3PCS

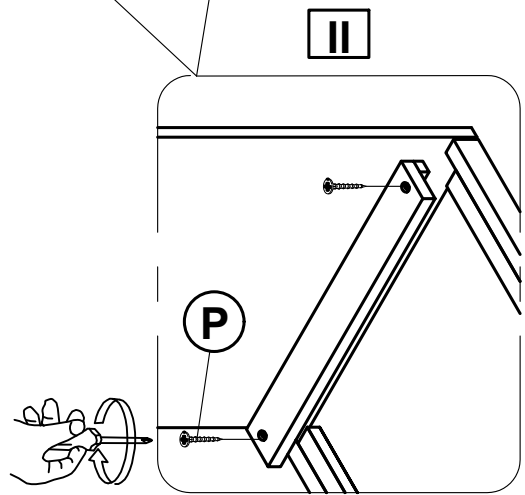
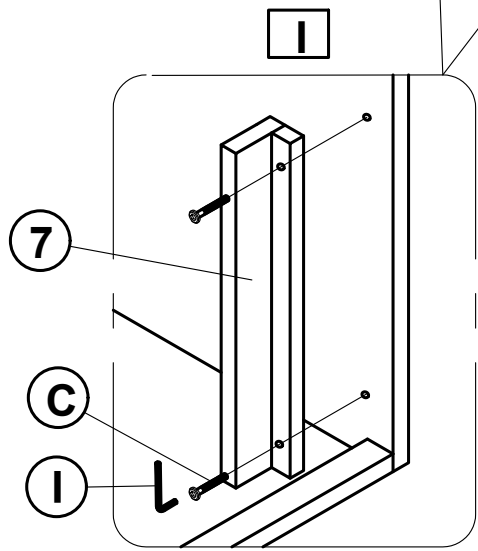
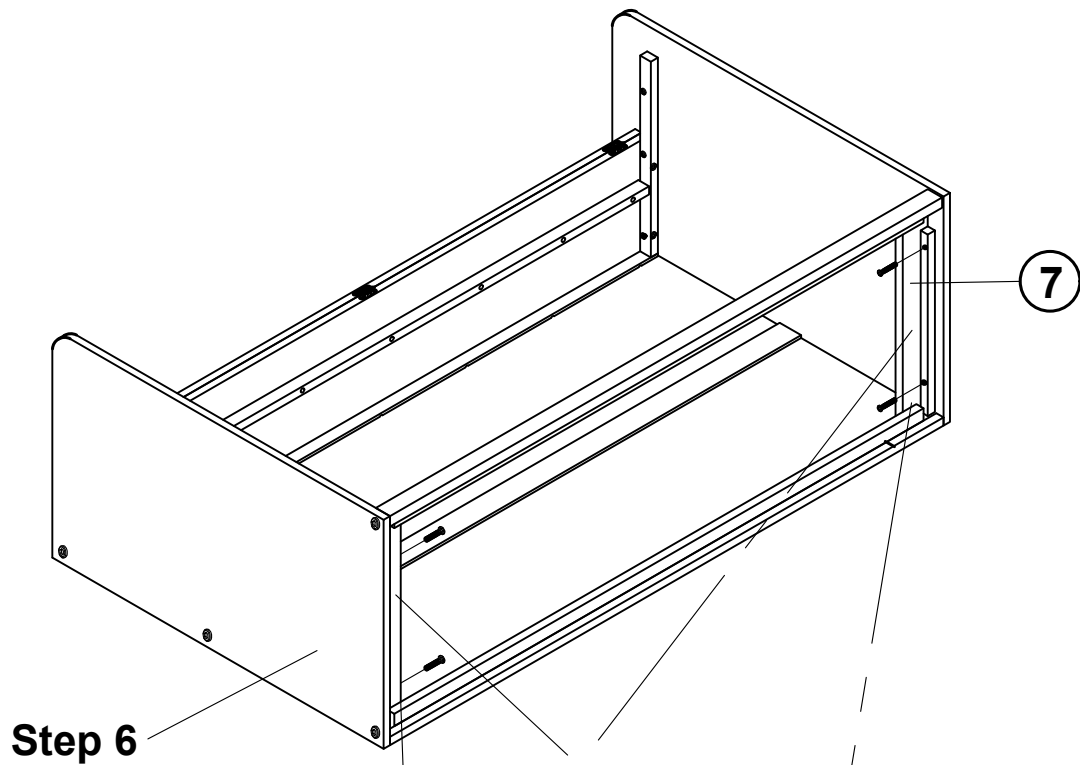

F		M6x60mm	4PCS
G		M6x13mm	4PCS
I		L4	1PC

step 7:
étape 7:



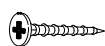

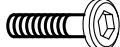
View inside / Voir à l'intérieur

P		4x30mm	4PCS
---	---	--------	------

C		M6x30mm	4PCS
I		L4	1PC

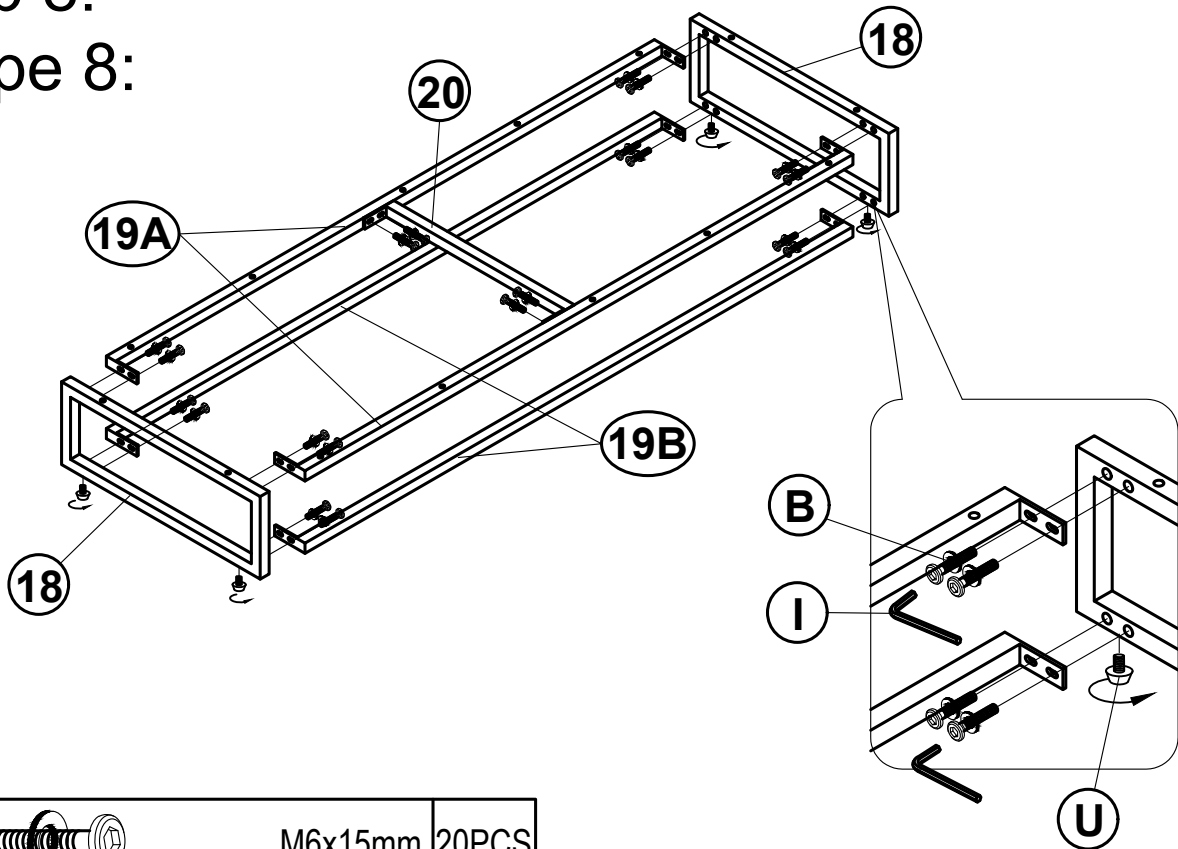
step 8:
étape 8:





B		M6x15mm	20PCS
I		L4	1PC

U		M6	4PCS
---	---	----	------

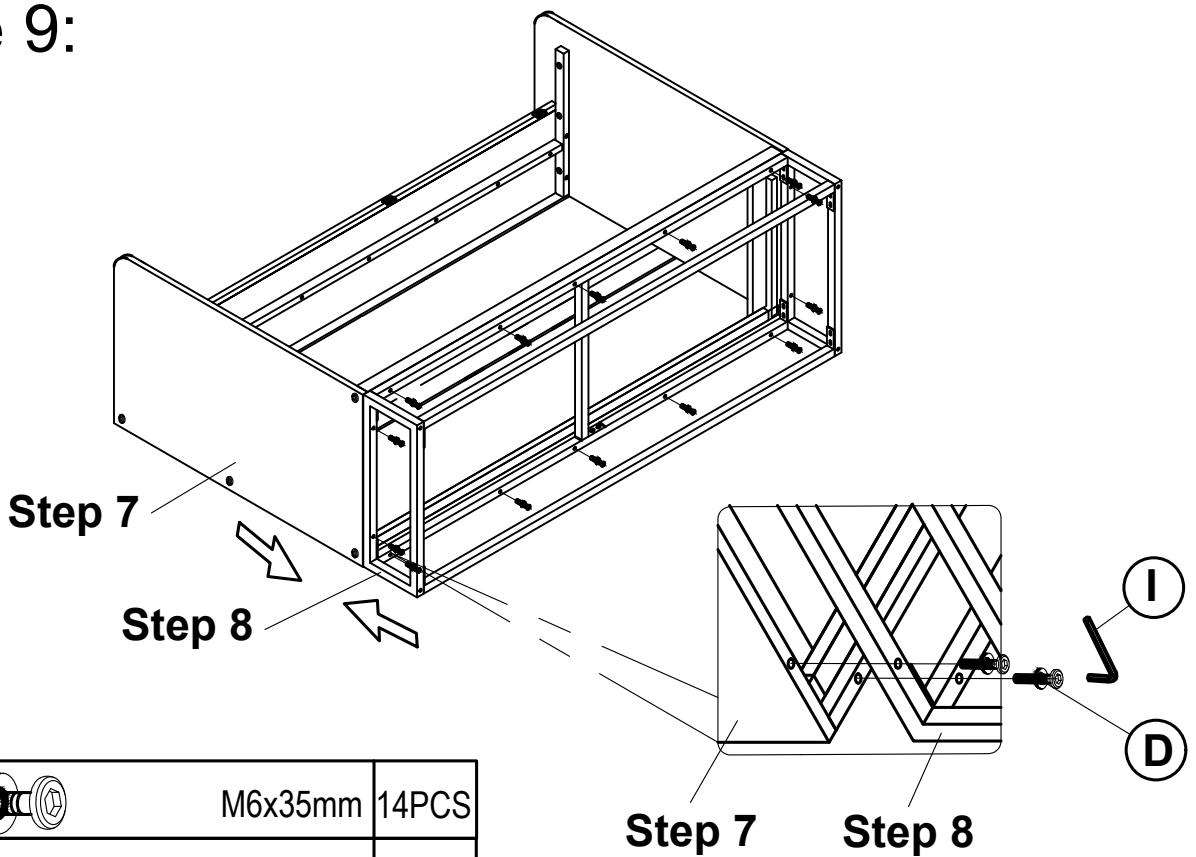
step 9:
étape 9:



D		M6x35mm	14PCS
I		L4	1PC

step 10:
 étape 10:

Step 9

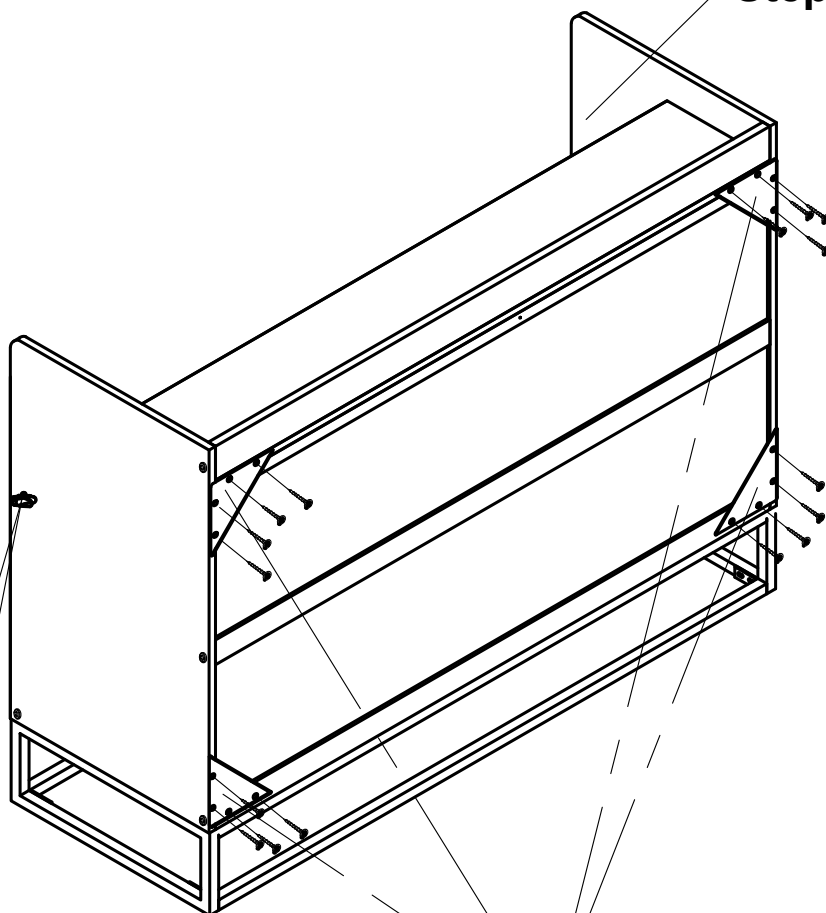

I

II

PILOT HOLES
 TROUS PILOTE

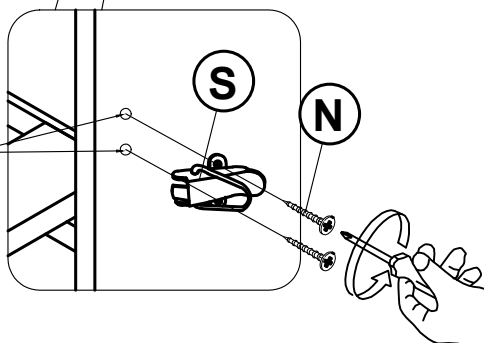

PILOT HOLES
 TROUS PILOTE

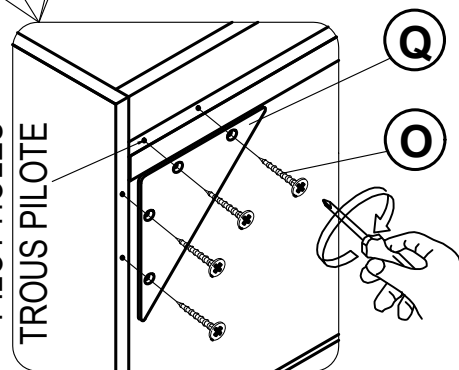

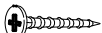

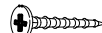
S			2PCS
N		3.5x15mm	4PCS

Q			4PCS
O		4x15mm	16PCS

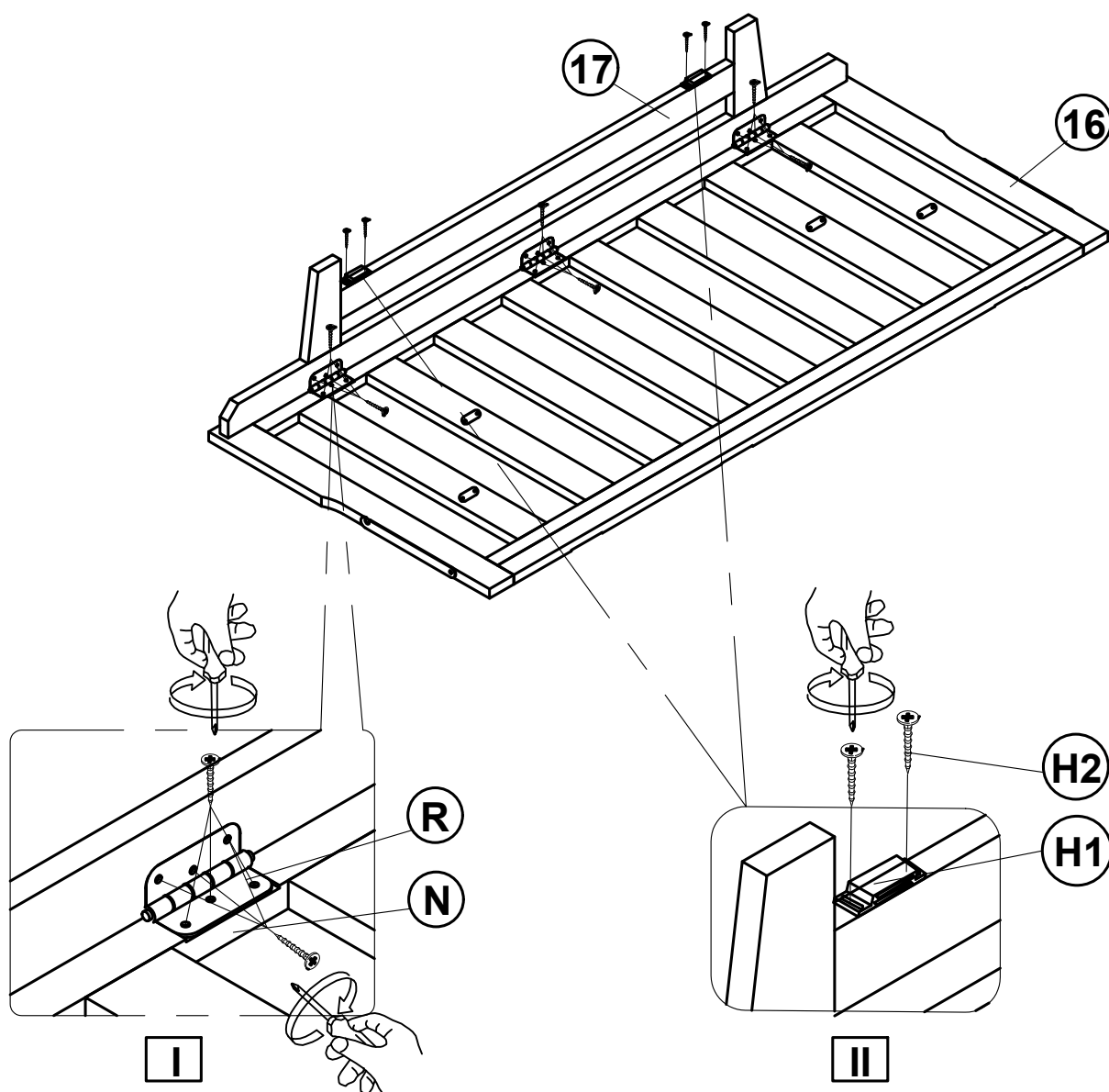
step 11:
 étape 11:

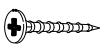



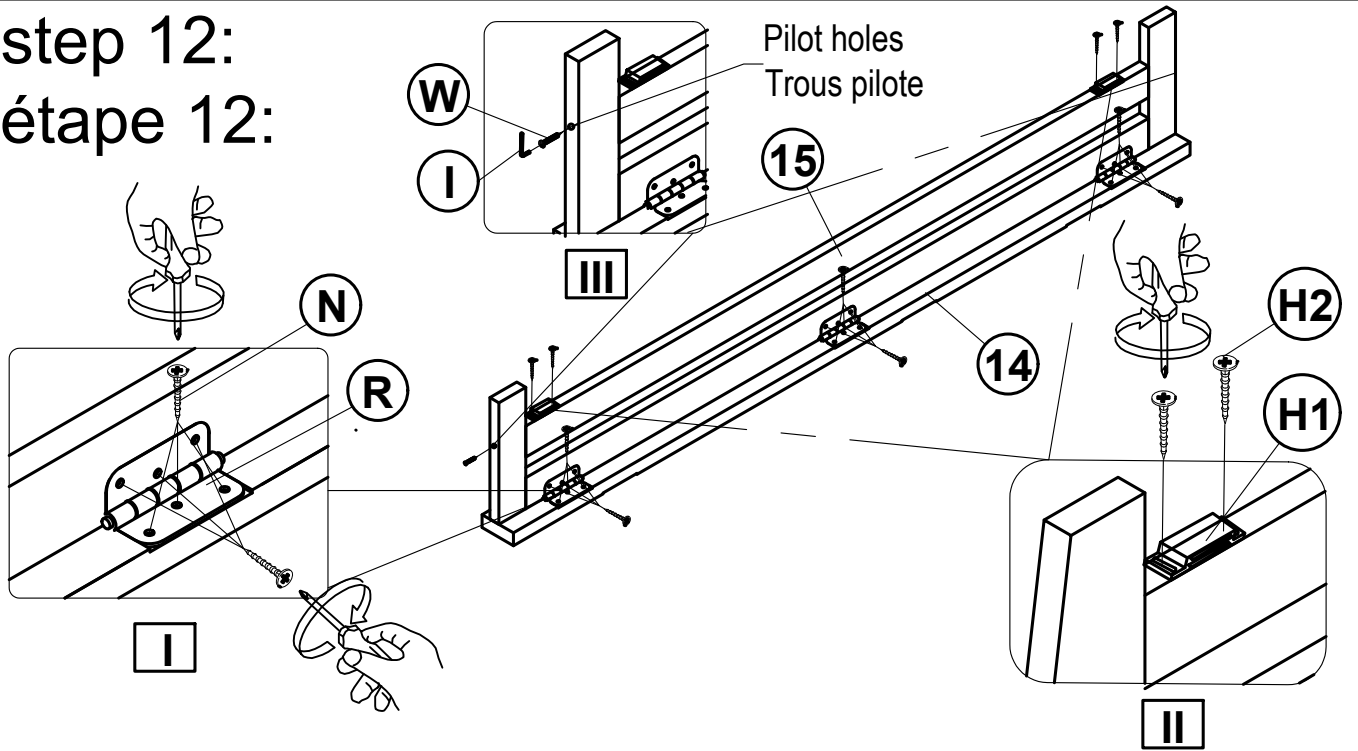

R		75mm	3PCS
N		3.5x15mm	18PCS

H1			2PCS
H2		3x12mm	4PCS

step 12:
étape 12:

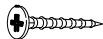

W		M6x35mm	2PCS
H1			2PCS
H2		3x12mm	4PCS

I		L4	1PC
R		75mm	3PCS
N		3.5x15mm	18PCS

step 13:
étape 13:

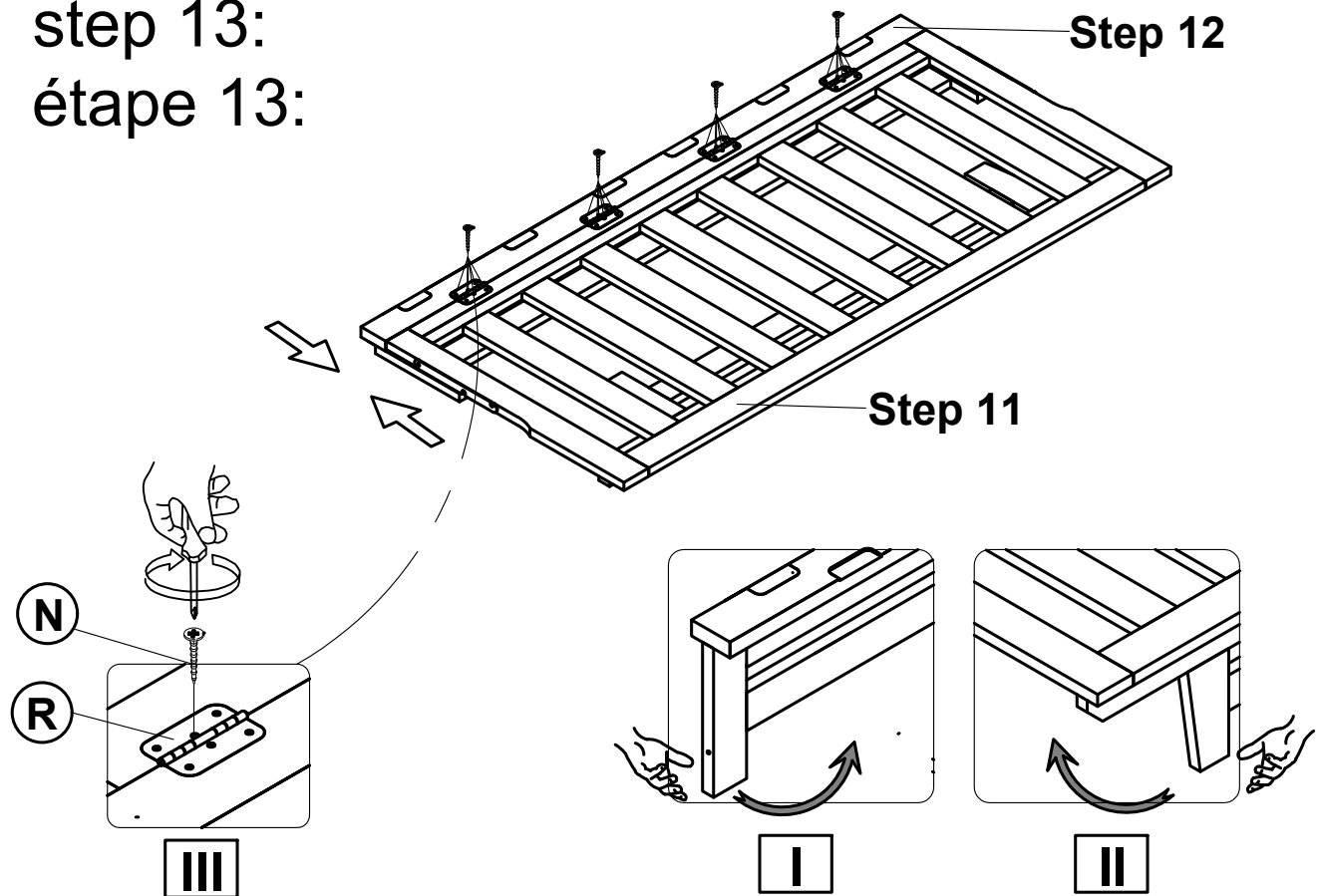



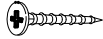

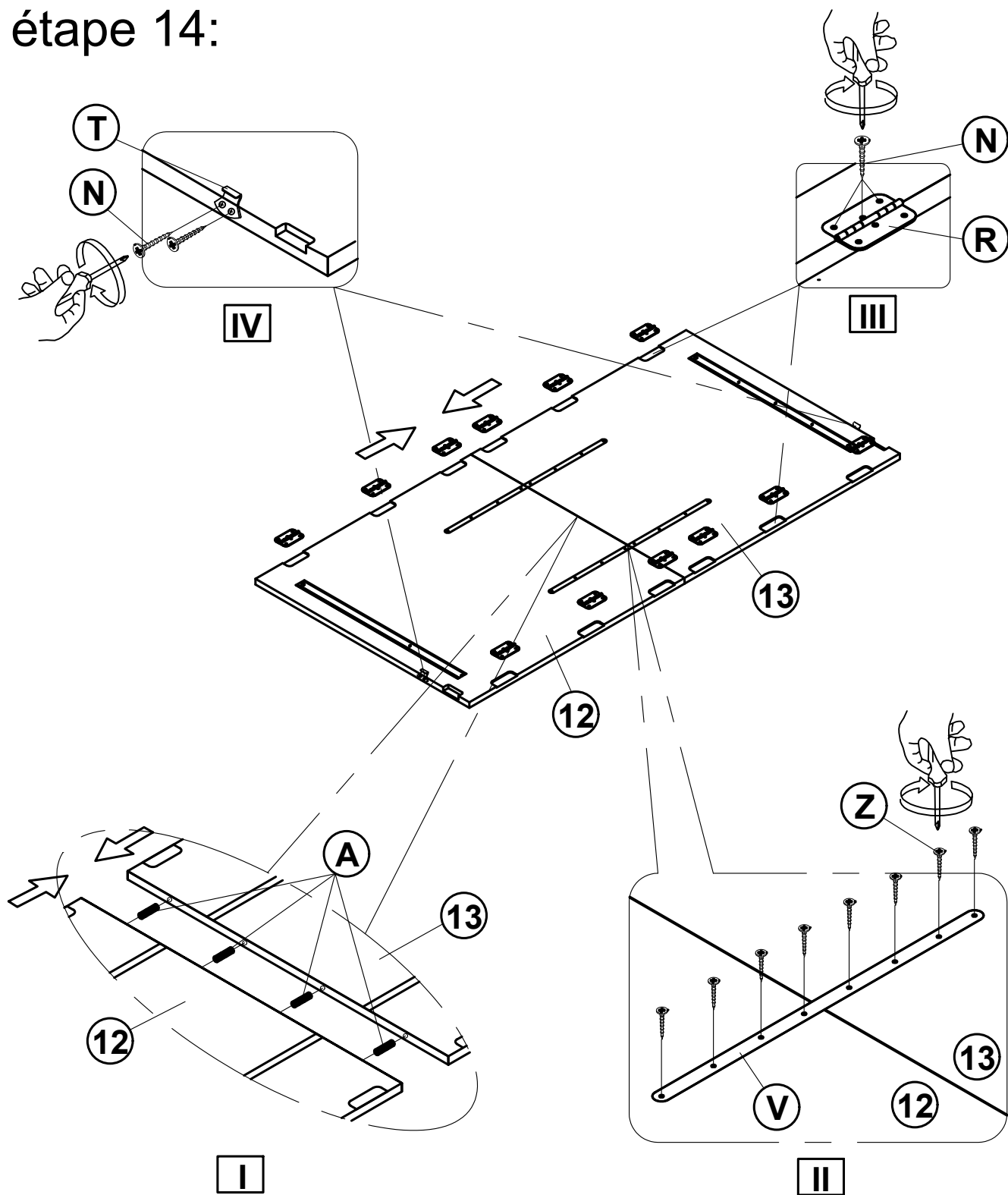

R		75mm	4PCS
---	---	------	------

N		3.5x15mm	24PCS
---	---	----------	-------

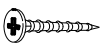
step 14:
étape 14:



R		75mm	12PCS
T			2PCS
N		3.5x15mm	40PCS

A		8x30mm	4PCS
V			2PCS
Z		4x15mm	16PCS

step 15:
étape 15:

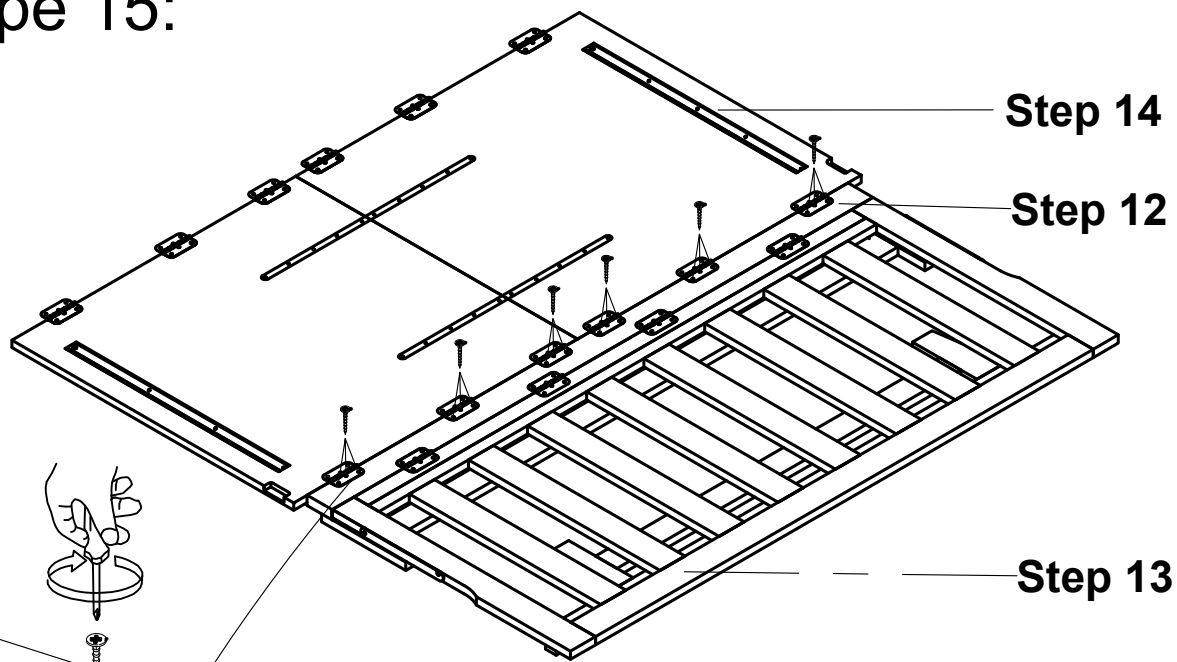

N

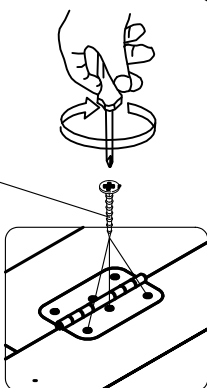

N

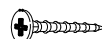

3.5x15mm 18PCS

step 16:
étape 16:

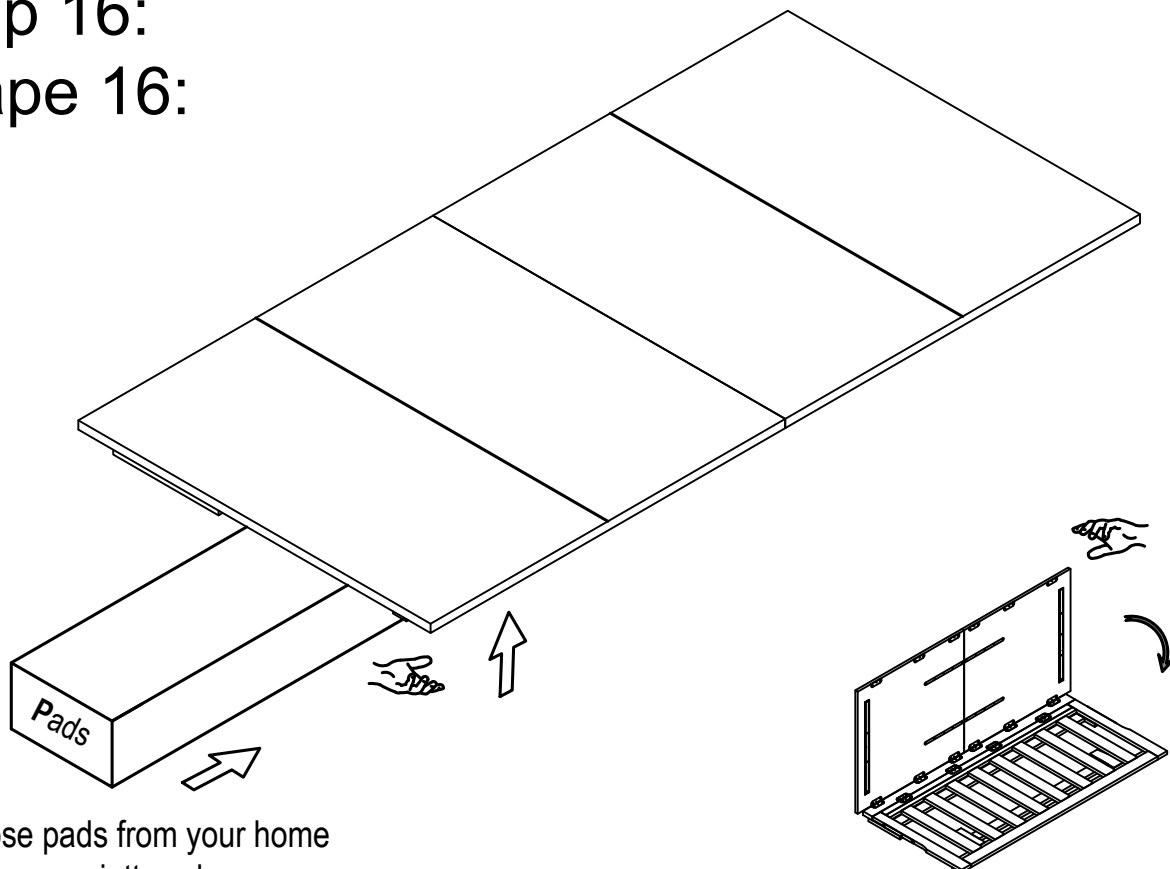

Take those pads from your home
Prenez ces serviettes chez vous

step 17:
étape 17:

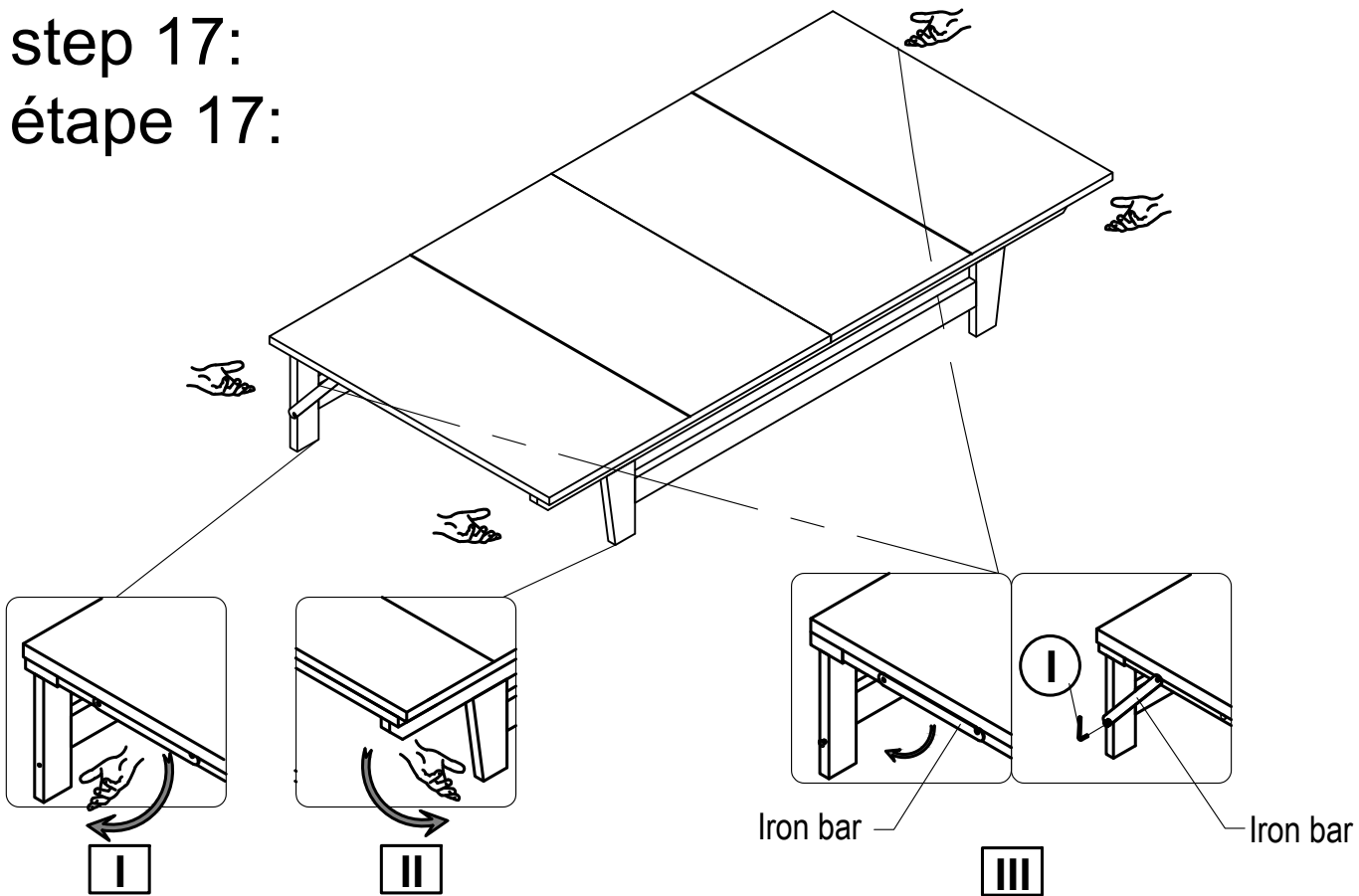

I		L4	1PC
---	---	----	-----

step 18:
étape 18:

Step 10

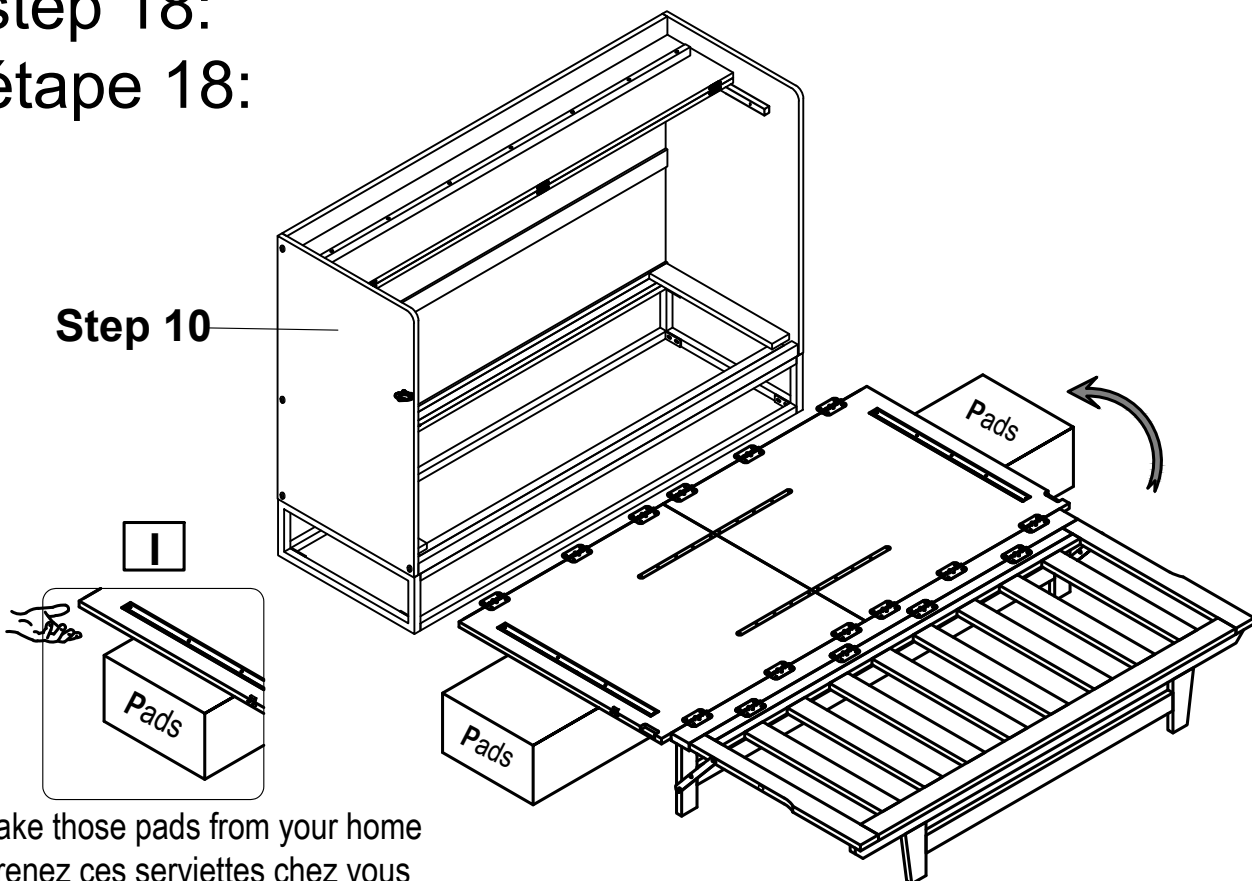

Take those pads from your home
Prenez ces serviettes chez vous

step 19:
étape 19:

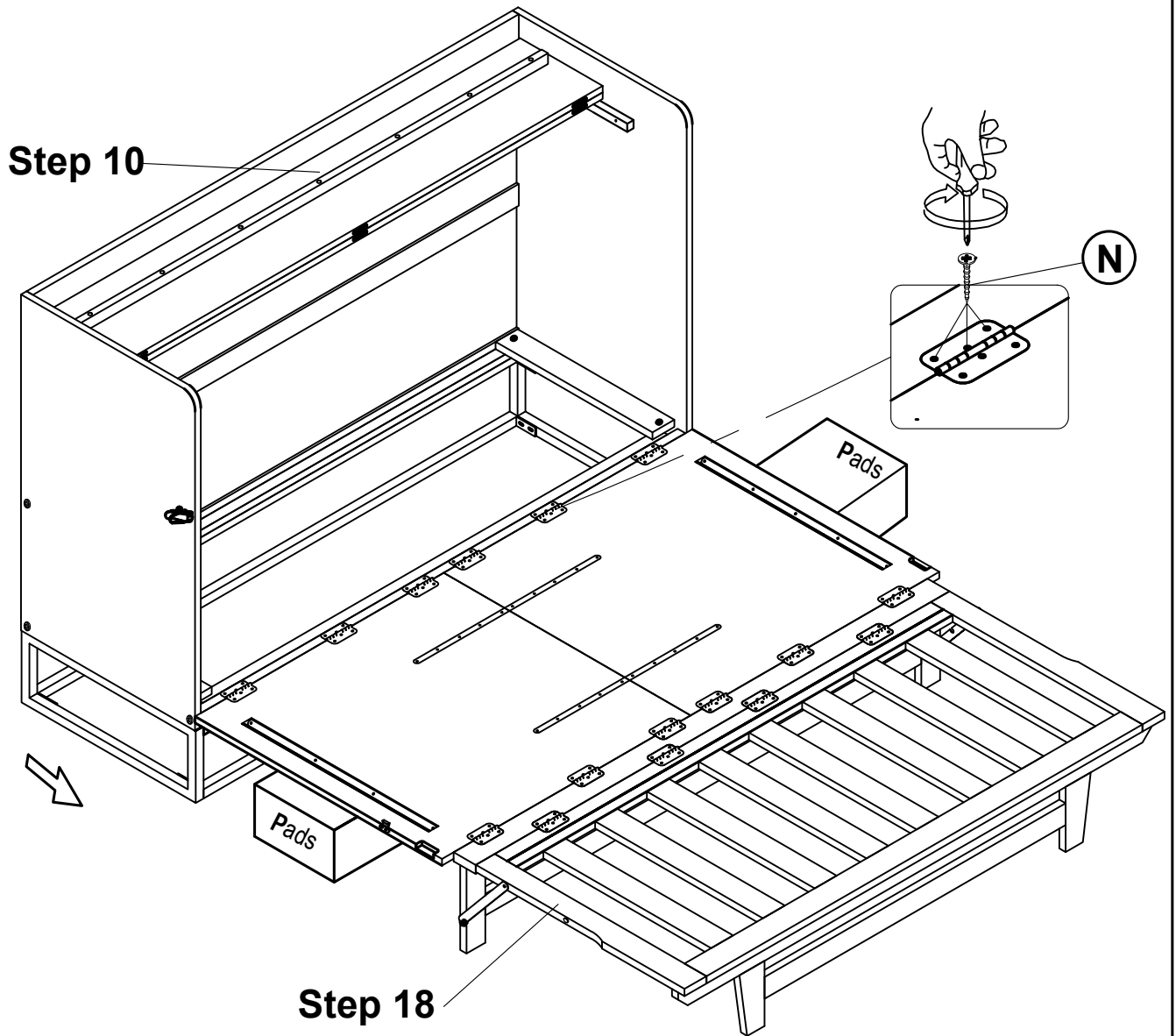

N		3.5x15mm	18PCS
---	---	----------	-------

step 20:
étape 20:

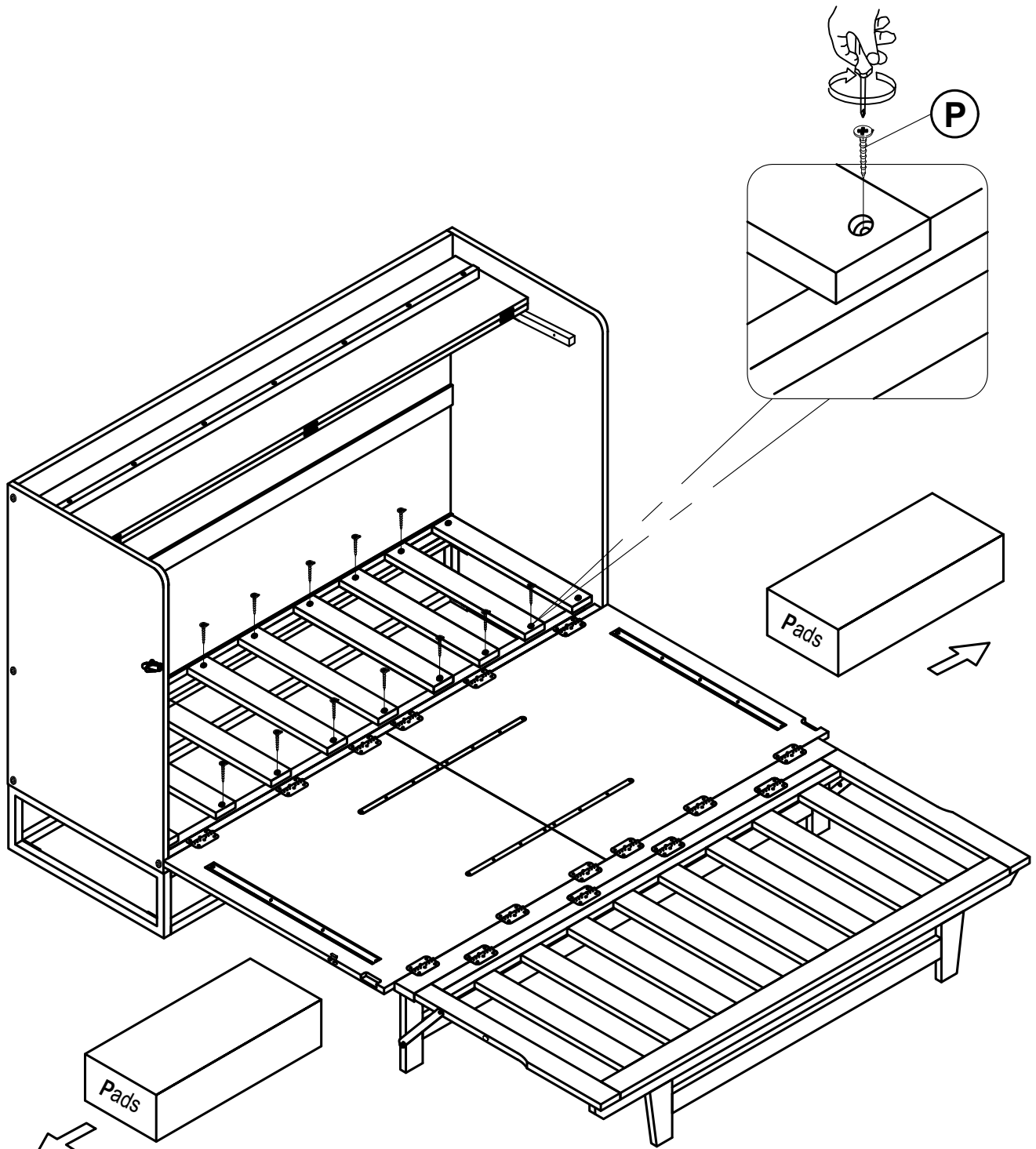

Remove block pads
Supprimer les tampons de bloc

P

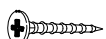

4x30mm 14PCS

step 21:

étape 21:

- Please make sure you have moved the iron bar from the middle leg frame to the wing frame before folding it inward to avoid damaging the hinge connection with the wood.
- Assurez-vous d'avoir déplacé la barre de fer du cadre de la jambe centrale vers le cadre de l'aile avant de plier vers l'intérieur pour éviter d'endommager la connexion de la charnière avec le bois.

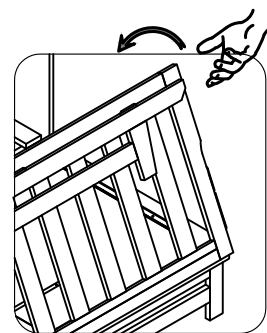
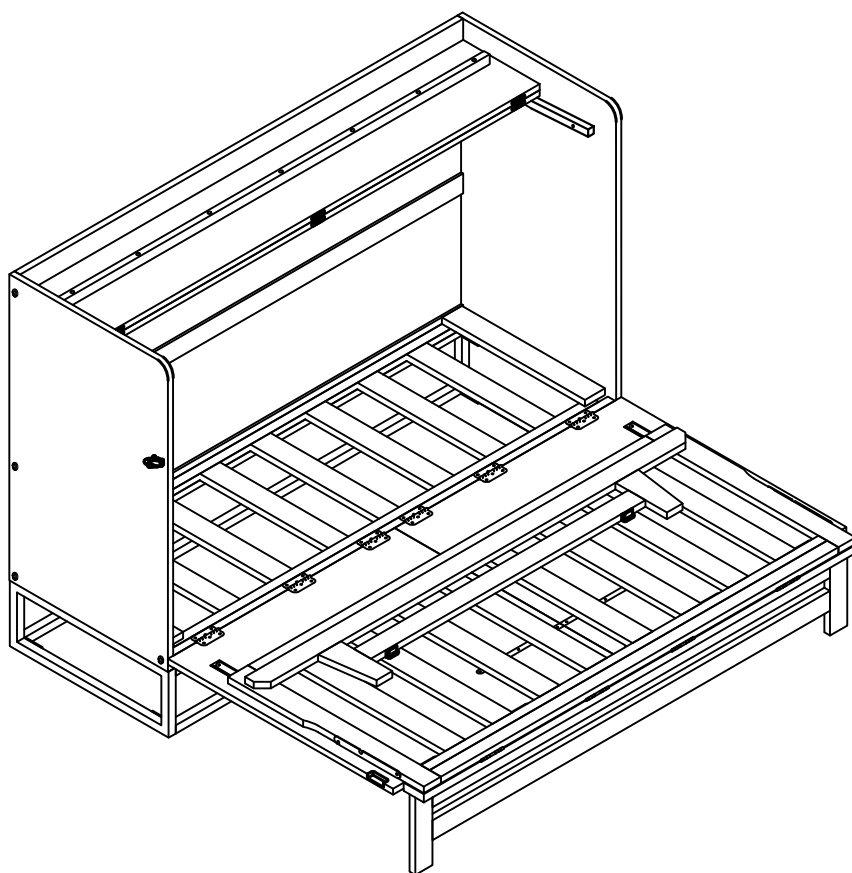

IV

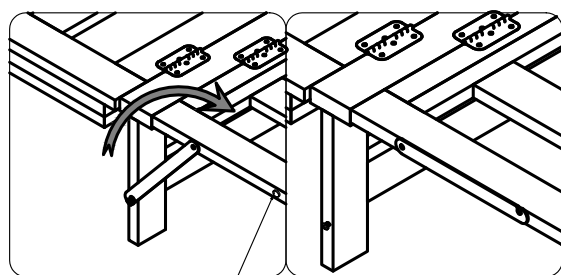

Magnet
Aimant

I

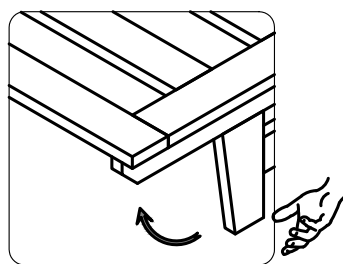

II

Magnet catches
Attaches aimants

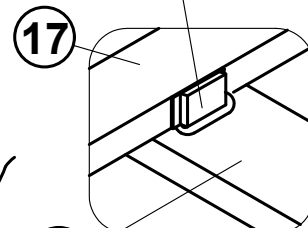

17

III

step 22:
étape 22:

I

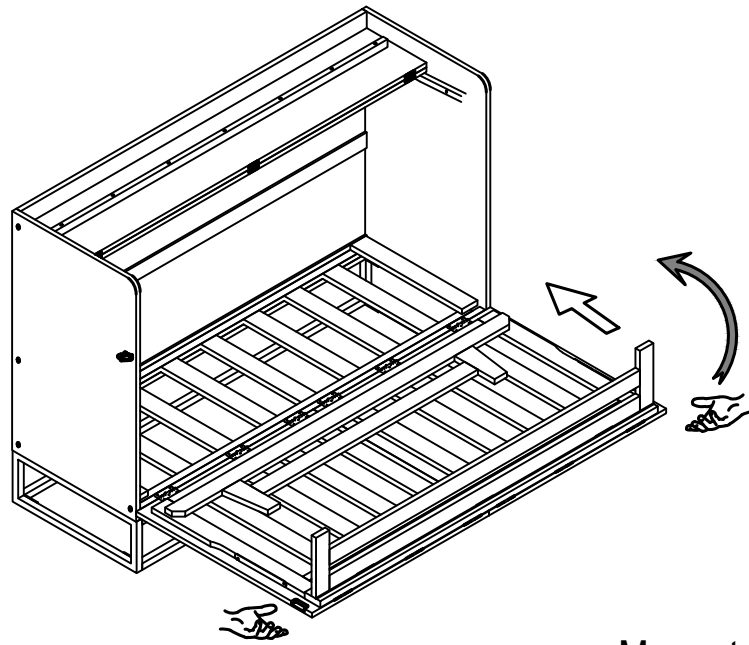

II

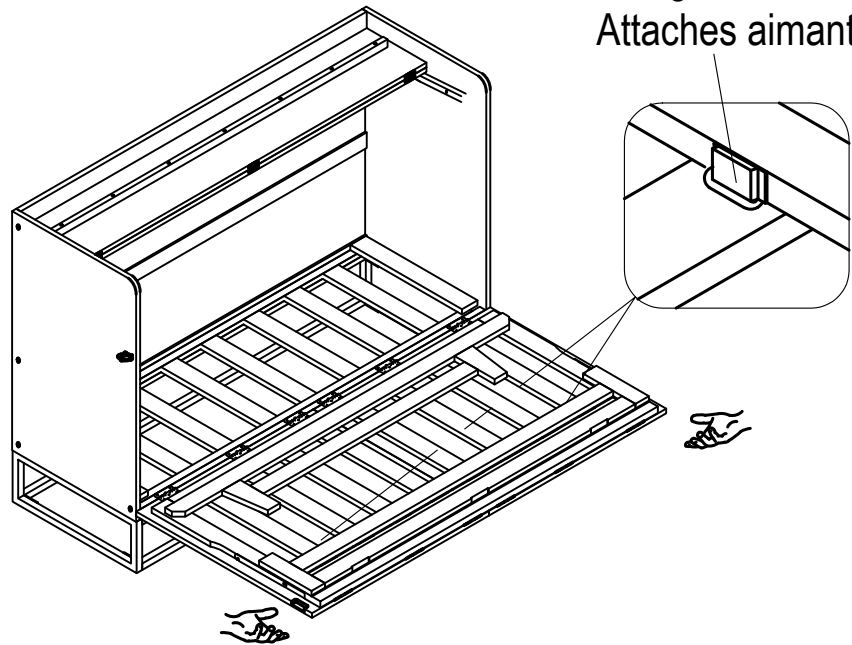

III

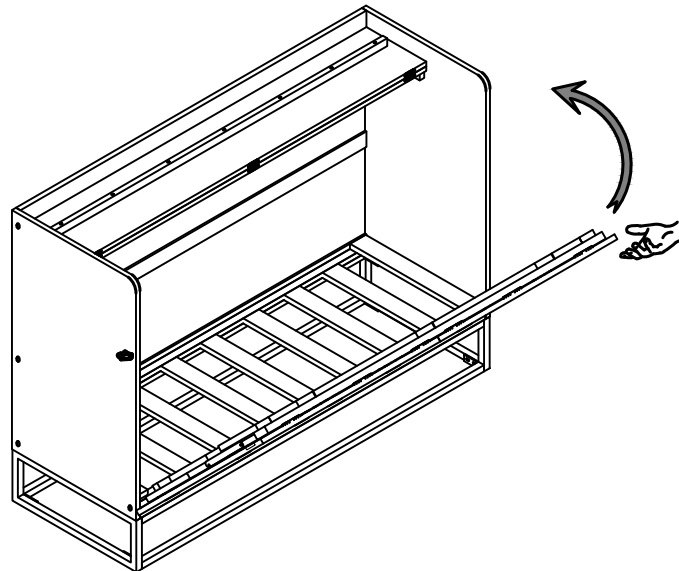

step 23:
étape 23:

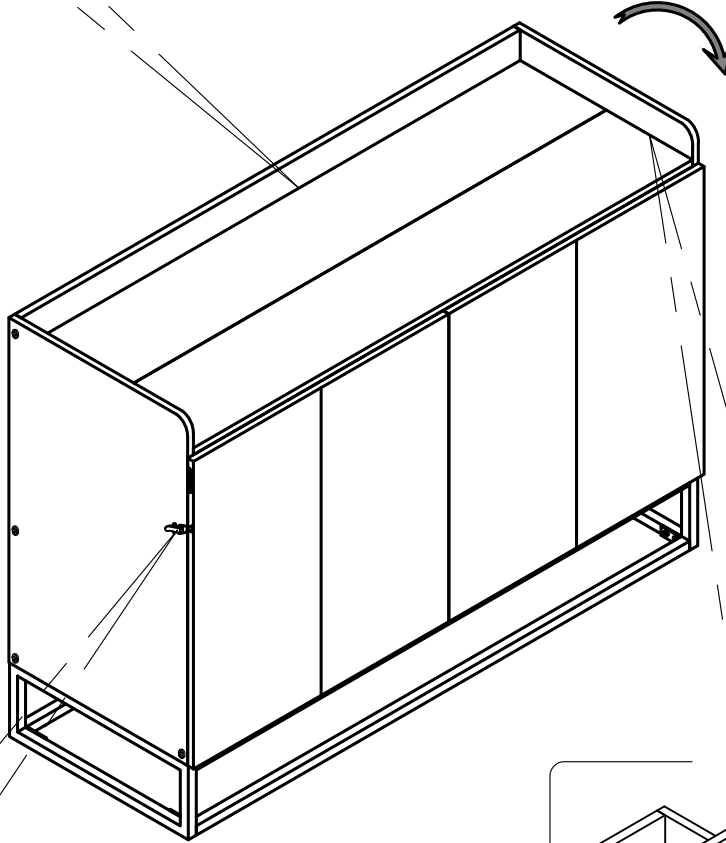
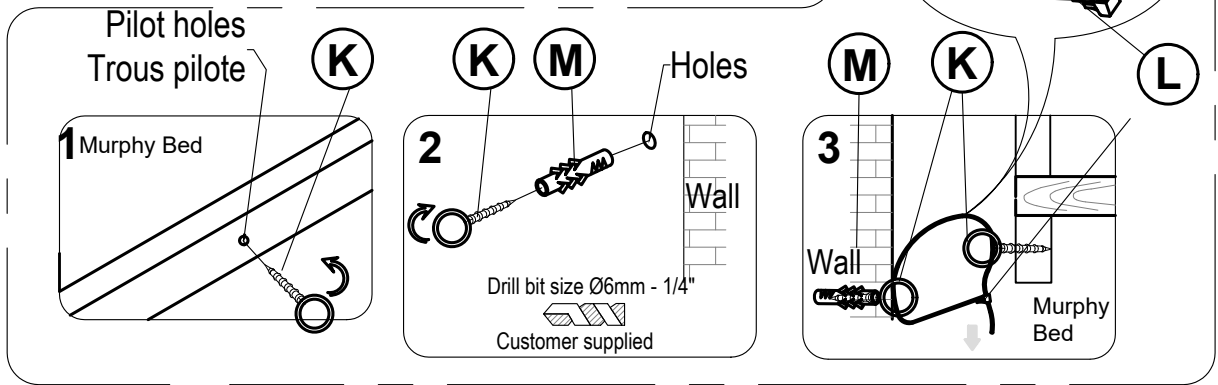

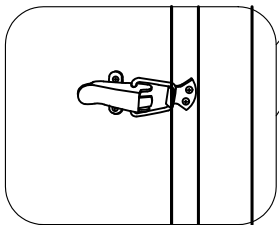

LOCK
VERROUILLAGE

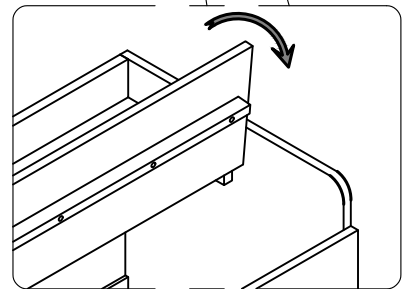

I



II

K		2PCS
L		1PC

M		1PC
---	--	-----