

# HAPPINESS HAPPINESS INSTALLATION



## CAUTION

Parts are placed at the bottom of the product.

- If you have any questions with the product, please contact us by:
- **Email: [customerservice@zoy-living.com](mailto:customerservice@zoy-living.com)**  
(we will reply to you within 24 hours)

# Assembly Instructions









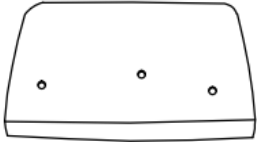

Model: KF3050K

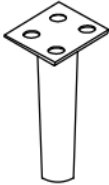
## CAUTION

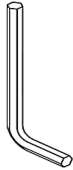
**DO NOT** use any sharp objects to open plastic wrapped components as this may result damage to product or components .

Your Sofa comes packaged in **Two** boxes. Carefully remove all of components from the packaging and setaside for assembly.

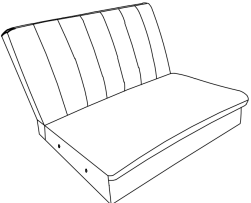
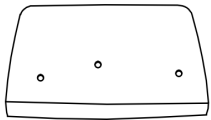
## Package Contents

|                             |   |   |   |   |
|-----------------------------|---|---|---|---|
| <b>BOX 1</b><br>KF3050KF46L |   |   |   |   |
|                             | <b>A*1</b>  | <b>B*1</b>  | <b>C*2</b>  | <b>D*2</b>  |
|                             |  |  |  |  |
|                             | 平头内六角M8 <b>E*6</b>  | <b>F*10</b>   | <b>G*1</b>  | <b>H*2</b>  |
|                             |  |  |   |   |
| <b>I*4</b>                  | 大扁头内六角 <b>J*20</b>  |   |   |   |
| <b>BOX 2</b><br>KF3050KF46R |  |  |  |   |
|                             | <b>L*1</b>  | <b>K*1</b>  | <b>C*2</b>  |   |

|  |  |  |  |  |
|--|--|--|--|--|
|  |  |  |  |  |
|  |  |  |  |  |

## Step1

Take out the left armrest (B) and right armrest (L) facing the sofa from the bottom pocket (A&K) of the sofa.

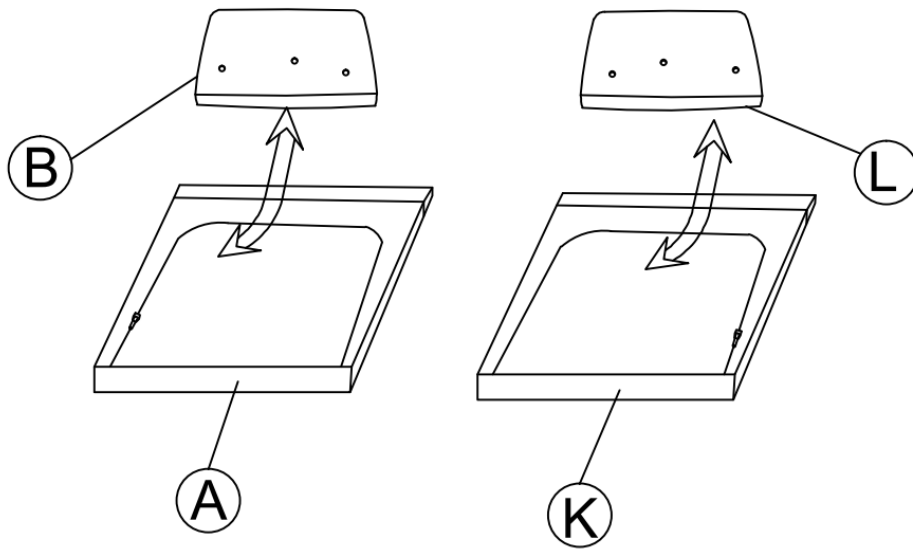

## Step2

As shown in the diagram, use a fully threaded screw (H) to pass through the washer (F), aligning the holes (A & K) on the two bases, and then tighten it securely with the wing nut (I).

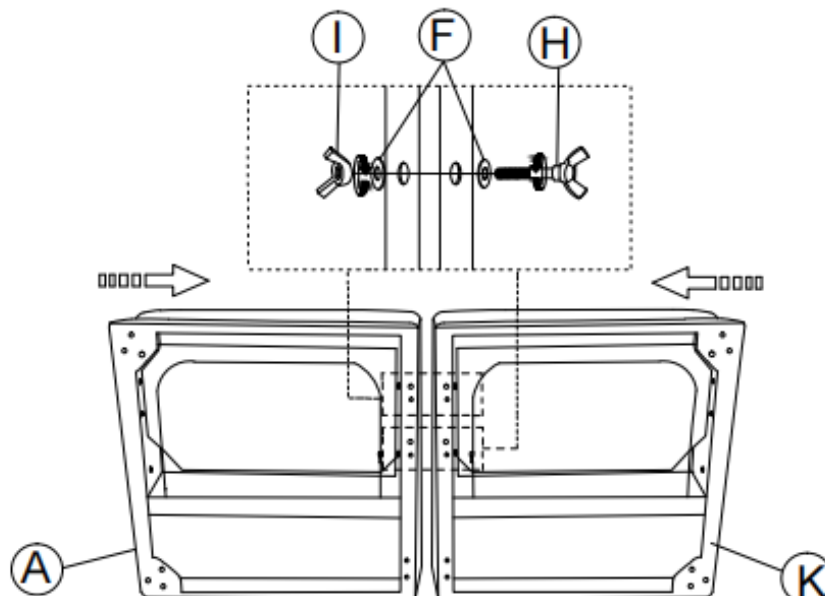

# 1 SOFA ASSEMBLY - BODY SETUP

## Step3

As shown in the figure, use the left-hand armrest (B) and right-hand armrest (L) to install the hardware components (E&F&G) onto the seat frame (A&K), ensuring that the armrests face outward toward the sofa.

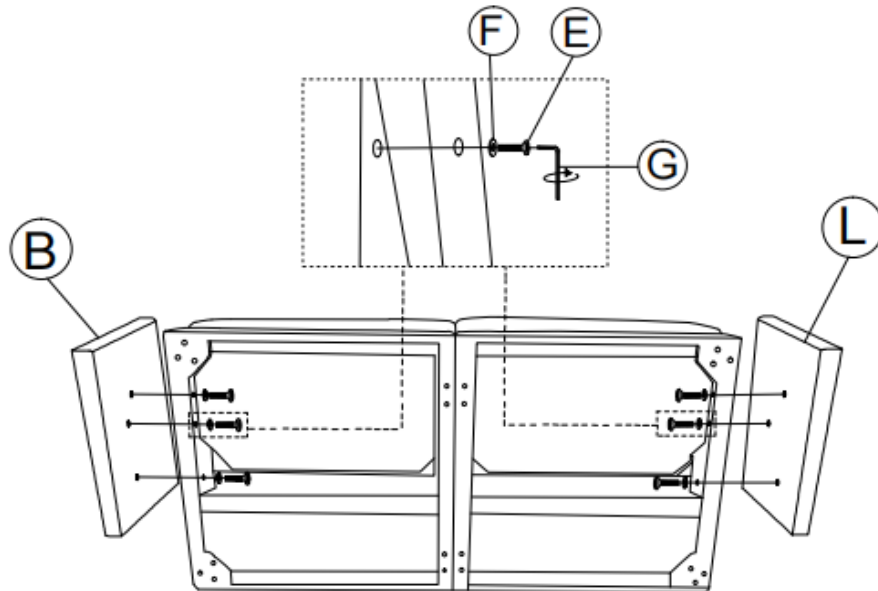

## Step4

As shown in the diagram, use wrench (G) to align screw (J) with the holes (C&D&G) on the metal foot, then secure it to the bottom of the seat frame (A& K). Be sure to tighten the screws securely before use for added safety.

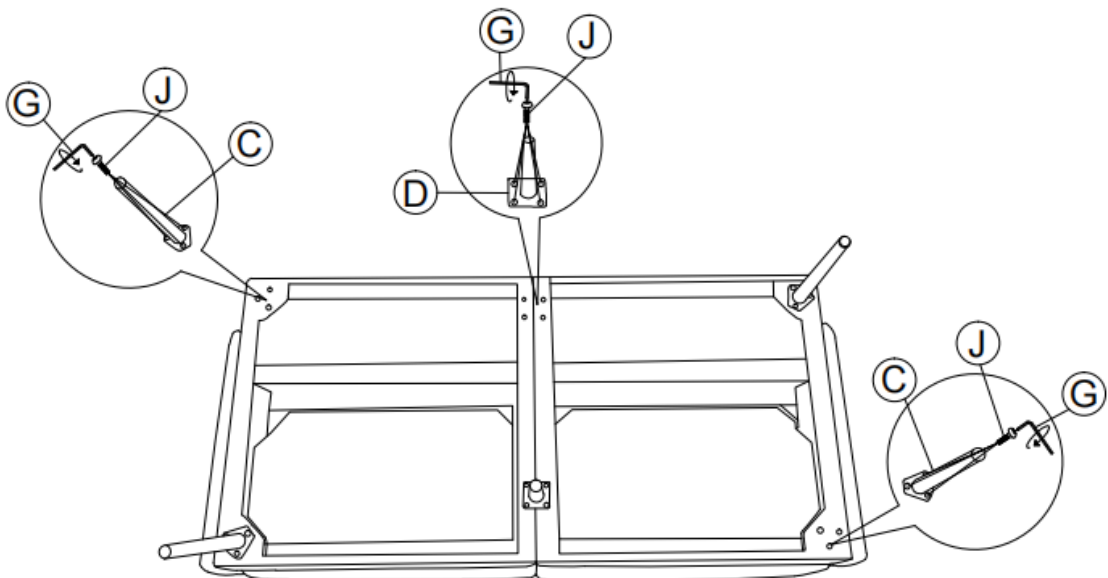

# 2 SOFA ASSEMBLY - WIRES CONNECT

Installation is complete

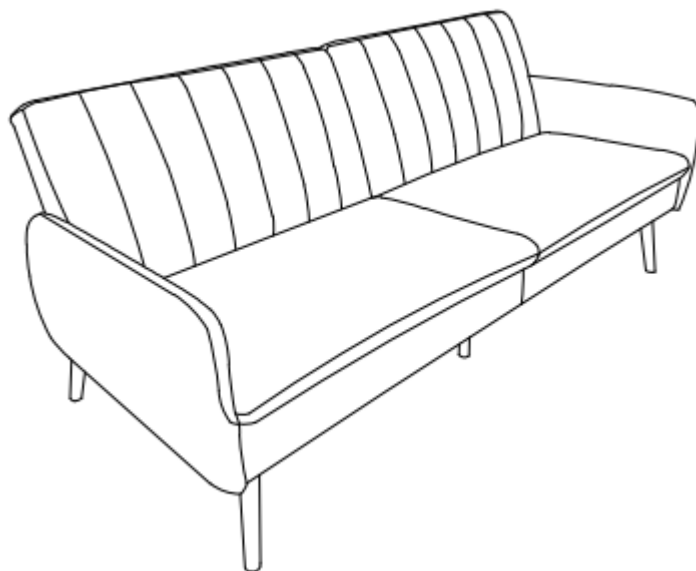

Sofa function display

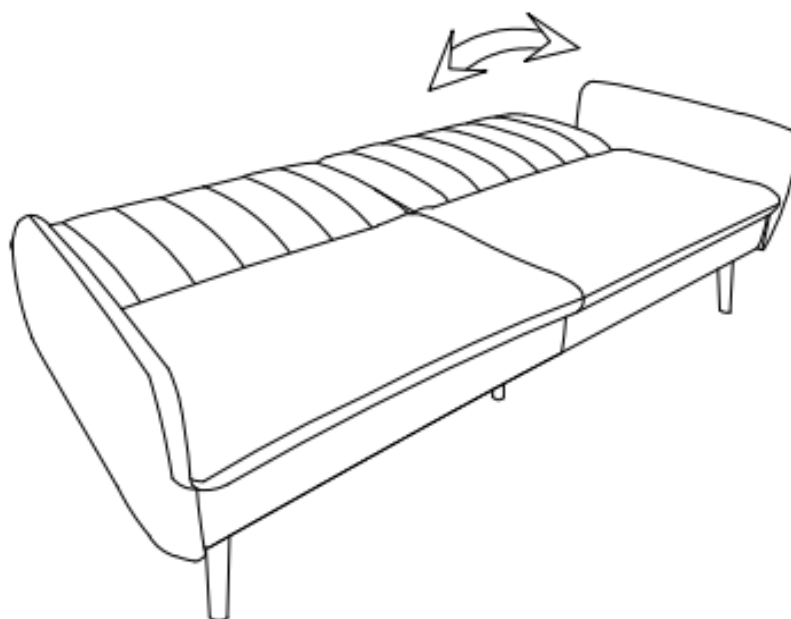

# 3 SOFA ASSEMBLY - WIRES CONNECT

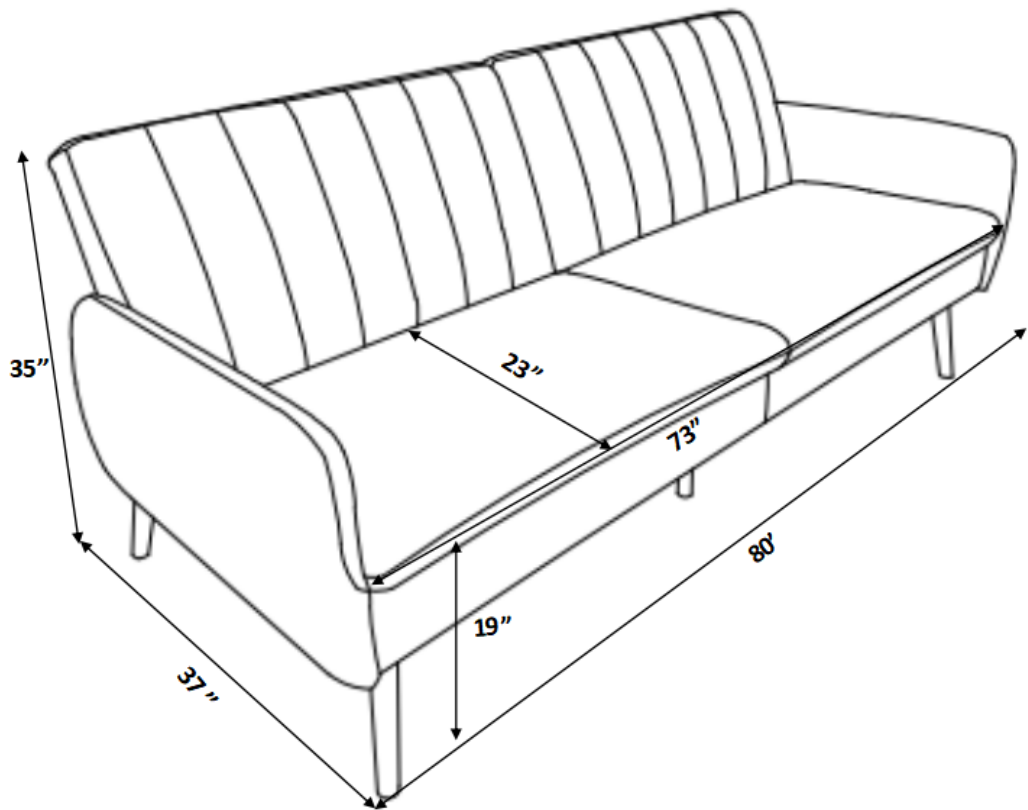

## Sofa

KF3050KF46L+KF3050KF46R

## ⚠️ WARNINGS

1. Please check if the components of the chair are all included and can be used normally.
2. Assemble all components according to the instruction correctly before you connect the chair to the power.
3. Please DO NOT sit on the armrests or footrest to eliminate the risk of tipping over.
4. If the chair is damaged or doesn't match the website description, please send clear pictures of the product and label of the carton to our service team for further help.
5. If the recliner doesn't work, you may try the following measures for self-checking firstly:
  - a) check if all the cables are connected;
  - b) check if the light of transformer is on.

If the chair still doesn't work, please feed the information back to our customer service in time and we will help you solve the matter as soon as possible.

6. If you have any questions about our products, please contact us by:

Email: [customerservice@zoy-living.com](mailto:customerservice@zoy-living.com) (we will respond to your inquiry within 24 hours)

