

ASSEMBLY INSTRUCTIONS

HARDWARE LIST

CARTON	NO.	SKETCH	DESCRIPTION	QTY
3-2	1		Bolt (1/4"*7/8")	10 PCS
	2		Bolt (1/4"*1-1/4")	8 PCS
	3		Spring Washer (1/4")	18PCS
	4		Washer (1/4")	18 PCS
	5		Allen wrench (4mm)	1 PC

PARTS LIST

CARTON	NO.	SKETCH	DESCRIPTION	QTY
3-1	A		Table top	1 PC
3-2	B		Wing Panel	2 PCS
	C		Pedestal	2 PCS
3-3	D		Base Ring	1 PC

Step 1

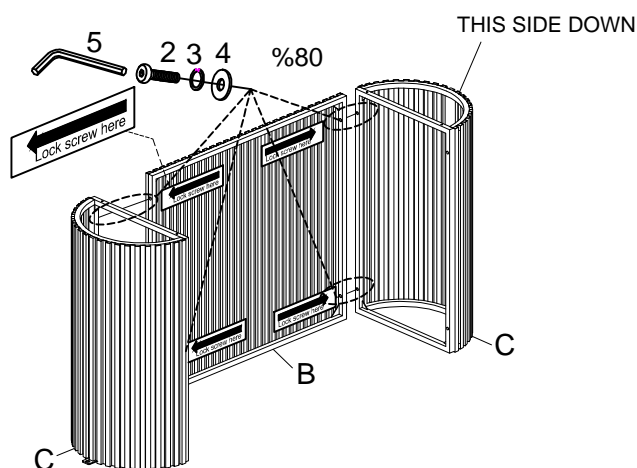

In this step, tighten the screws to 80%.
Note: Do not lock the screws.

Step 2

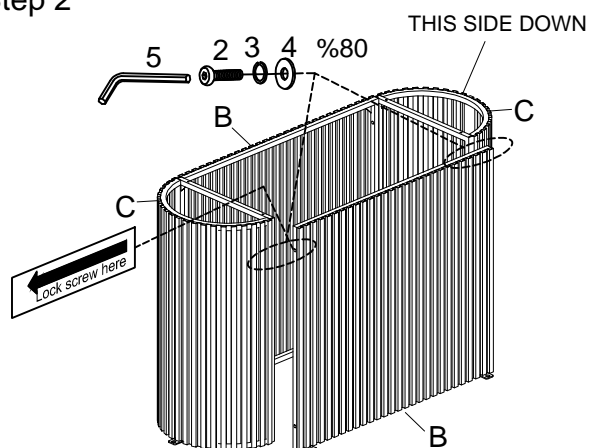

In this step, tighten the screws to 80%.
Note: Do not lock the screws.

Step 3

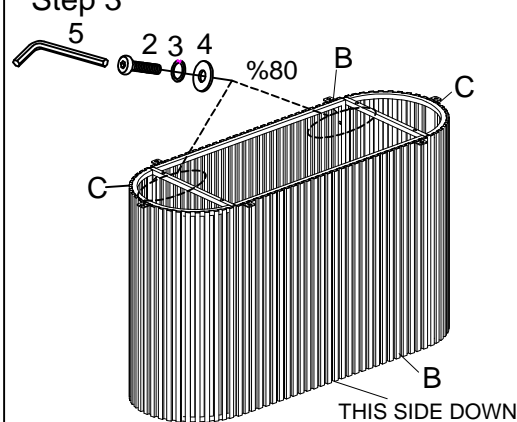

With the assistance of an adult partner, place the base upside down. Then, lock the Wing Panel (B) and Pedestal (C).
In this step, tighten the screws to 80%.
Note: Do not lock the screws.

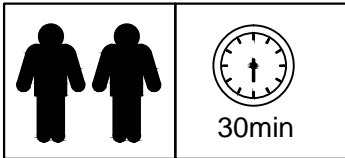

ASSEMBLY INSTRUCTIONS

Step 4

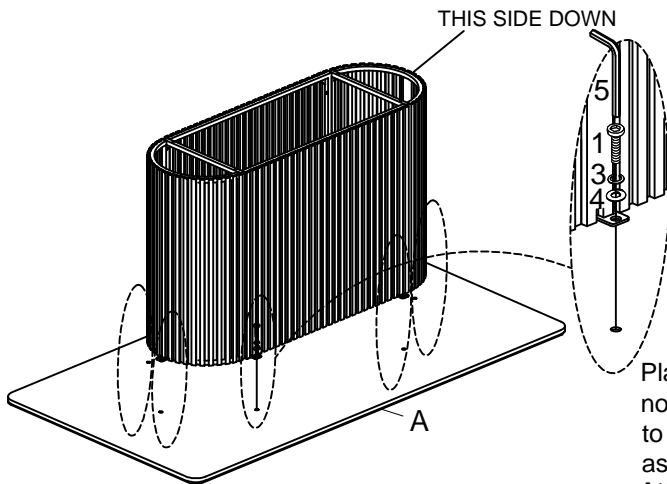

Place the tabletop facedown on a clean, non-marring surface. Attach the table base to the bottom of the tabletop using screws, as shown in the pictures.
Attention: When locking the tabletop, please use Short Bolt(1).

Step 5

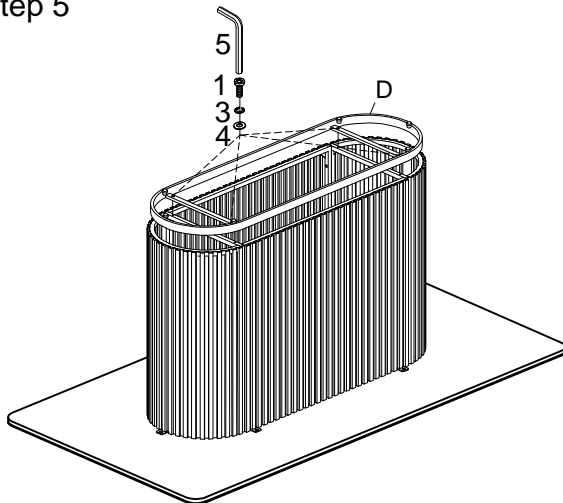

Step 6

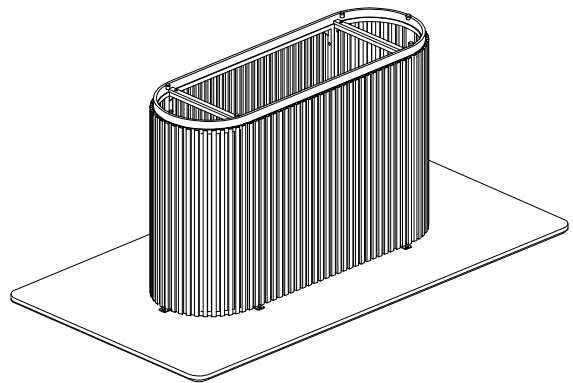

Note: Fully tighten all bolts at this step.

Step 7

