

ASSEMBLY INSTRUCTIONS BAR AND COUNTER STOOL

ASSEMBLY
REQUIREMENTS:

1-Person
Assembly

30 MINUTES
Assembly Time
Per Chair
(Approximate)

Tools Required:
(Not Provided)

Phillips
Screwdriver

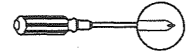

Thank you for purchasing our product!

Please refer and use this assembly instruction to assemble the product. Contact our customer service department in case there are any missing or damage parts or hardware. Replacement parts are normally shipped within 2 or 3 days.

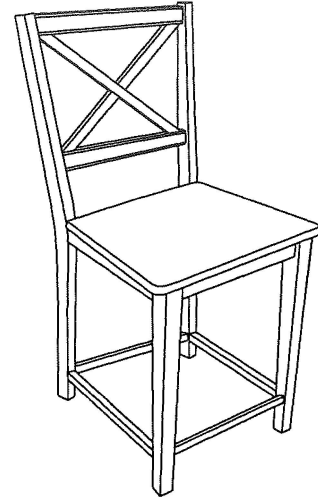

We appreciate your business!

ASSEMBLY PREPARATION

1. Remove all packaging materials, staples and packing straps from the carton.
2. Refer to Parts List and Hardware List and ensure they are complete before you start assembling.
3. Place all wooden parts on a clean, flat and soft surface (e.g. carpet or rug) to prevent parts from getting scratched.

SAFETY PRECAUTION:

1. KEEP ALL HARDWARE PARTS OUT OF REACH OF CHILDREN.
2. DISPOSE PLASTIC PACKAGING MATERIAL IMMEDIATELY TO AVOID ANY RISK OF SUFFOCATION TO CHILDREN AND ANIMALS.

TIPS FOR ASSEMBLY:

1. Allow ample room for assembly and in close proximity to where product will be placed.
2. Assemble the product on a surface that does not scratch or damage the exterior gloss and finish of the furniture.
3. Please check all of the parts and quantities are included before assembly. Contact customer service for missing parts.
4. Identify all of the parts, hardware and quantities required for each step.
5. During assembly, do not over-tighten any fittings as this may cause damage.
6. DO NOT USE POWER TOOLS TO ASSEMBLE THIS PRODUCT.
7. Always place the product on a flat surface.
8. Do not sit or stand on the partially assembled product; only use the product for which it is intended.

CARE AND MAINTENANCE

- Use a slightly damp cloth to clean the product. Do not use bleach or abrasive cleaning material.
- Check all the fittings periodically and re-tighten as necessary. Do not use the product if any of the parts is damaged or broken.
- Never allow any kind of liquid to remain on your furniture. Absorption can cause wood to warp or delaminate.
- Do not place hot items (e.g. hot drinks) directly onto the wood surface.
- Do not drag and/or pull the furniture.

This product is for indoor and household use only - not for commercial use.

ASSEMBLY INSTRUCTIONS BAR AND COUNTER STOOL

Parts List (For 1 Nos . Of Stool)

| NO | PARTS LIST | QTY |
|----|-----------------|-----|
| 1 | CHAIR BACK | 1 |
| 2 | SIDE RAIL (L/R) | 2 |
| 3 | STRETCHER (L/R) | 2 |
| 4 | FRONT LEG | 1 |
| 5 | WOODEN SEAT | 1 |

STEP 1

Attach Left and Right Side Rail (2) with the labels FL and FR towards the Front Leg (4) as shown. Fasten with JCBC Bolt (C) fitted with Spring Washer (D) and Flat Washer (E) using Allen Key (F).
Do not tighten completely at this time.

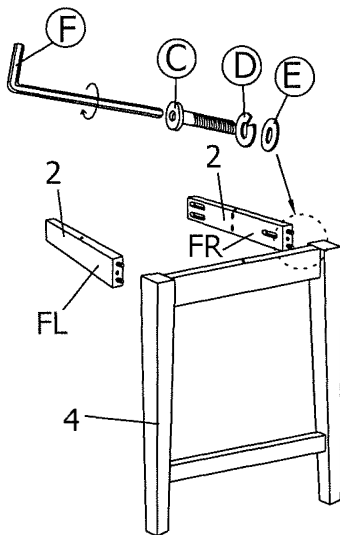

STEP 3

Step 3 - 1

Position the chair frame assembly with the legs facing up as shown. Use Screw (A) to fasten the Left and Right Stretchers (3) to the legs with a Phillips Screwdriver (Not Provided).

Step 3 - 2

Place the Wooden Seat (5) bottom-side up. Center the seat frame to the Wooden Seat with rear of the seat against the Chair Back. Use Screw (B) to fasten the Wooden Seat to the seat frame.

Gently nail Leg (G) into each end of the leg.
Place the chair right-side up.

The assembly of the chair is complete.

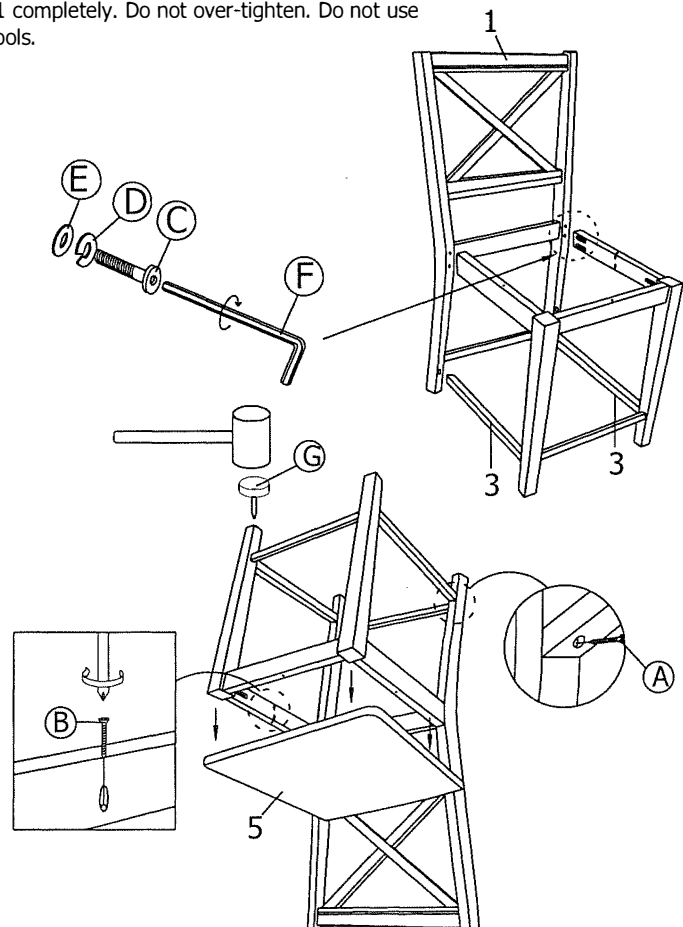

Hardware List (For 1 Nos . Of Stool)

| NO | Description | QTY | Extra |
|----|--|-----|-------|
| A | CSK SCREW M4 x 38mm  | 4 | 1 |
| B | CSK SCREW M4 x 32mm  | 3 | 1 |
| C | JCBC BOLT M6 x 50mm  | 6 | 1 |
| D | SPRING WASHER  | 6 | 1 |
| E | FLAT WASHER  | 6 | 1 |
| F | ALLEN KEY  | 1 | |
| G | NAIL LEG  | | 1 |

*Extra Hardware For Spare Use.

STEP 2

Attach the Left and Right Stretcher (3) - with the pre-drilled screw-holes faced down - to the Front Leg and Side Rail subassembly completed in Step 1. Next, insert the other ends of the Side Rail and Stretcher to the Chair Back (1). Fasten Side Rail to Chair Back with JCBC Bolt (C) fitted with Spring Washer (D) and Flat Washer (E) using Allen Key (F).
Do not tighten completely until all 4x (C) are in place. Tighten JCBC Bolt (C) in Step 1 completely. Do not over-tighten. Do not use power tools.