

# ASSEMBLY INSTRUCTIONS

Counter & Bar Height Swivel Stool#: M-1001

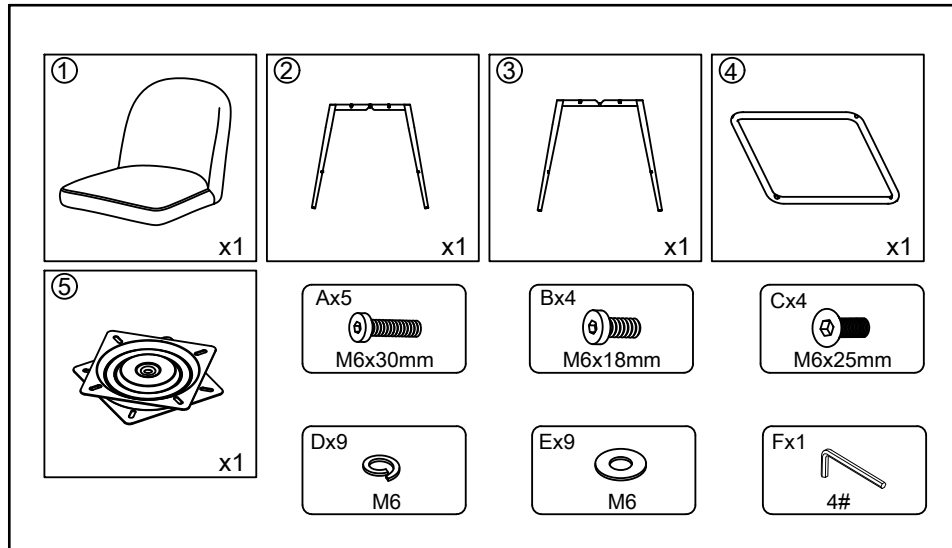
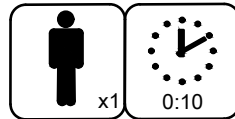
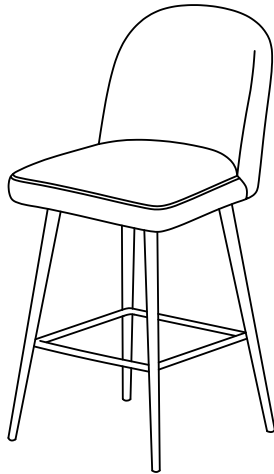

Please read through the instructions below to familiarize yourself with the parts and steps before assembly.

**Note: Do NOT use power tools for assembly**

**1** Unpack and place seat (1), legs (2&3), foot rest (4) and swivel plate (5) on a clean surface. Attach leg (2) to leg (3), using bolt (A), lock washer (D), flat washer (E) and allen wrench (F).  
**Note: Do not fully tighten yet.**

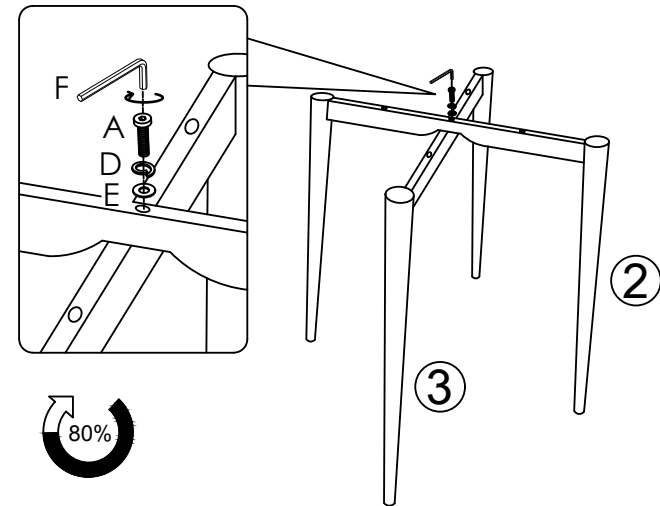

**2** Loosely attach the bolts (C) one by one and **keep them loose. Do not fully tighten.** After loosely attach the first bolt, move on to the diagonal bolt. After all 4 bolts are attached, use allen wrench (F) to tighten.

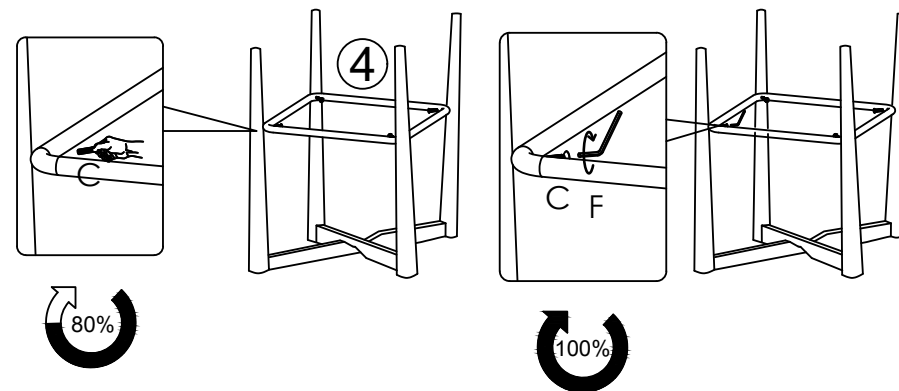

**3** Fully tighten the bolt (A) in step 1 with allen wrench (F). Then attach swivel plate (5) to assembled legs in step 2, using bolts (A), lock washers (D), flat washers (E) and allen wrench (F).

**Note: Do not fully tighten yet.**

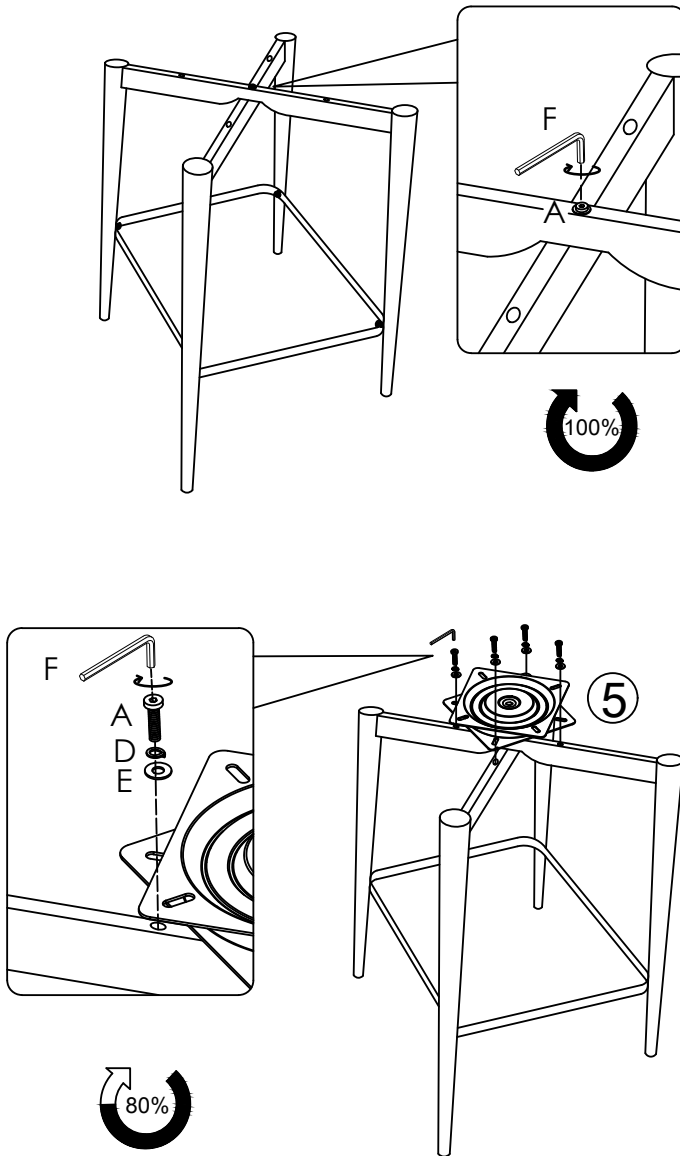

**4** Put assembled legs in step 3 on a flat surface. Push legs up or down as necessary to level. **Once level, tighten all bolts.**

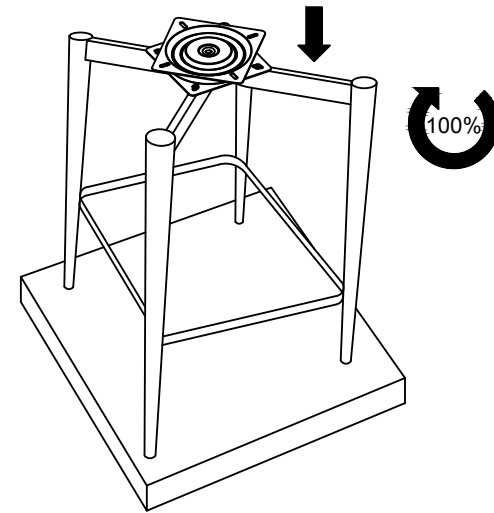

**5** Turn assembled legs in step 3 upside down, and attach them to seat (1), using bolts (B), lock washers (D), flat washers (E) and allen wrench (F).

**Note: Tighten all bolts.**

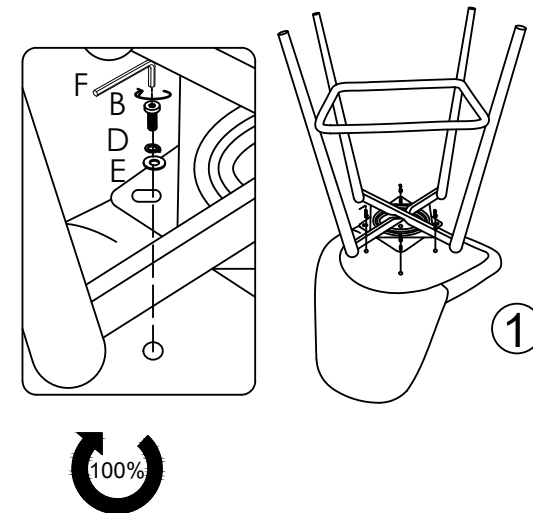

6

Turn assembled chair upright and place on a flat surface.

**Note: Each leg has an adjustable foot leveler to help level your chair.**

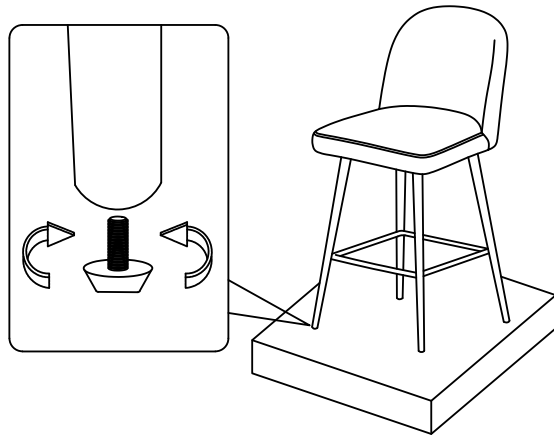

7

Assembly Completed. Enjoy.

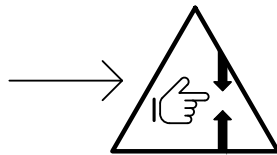
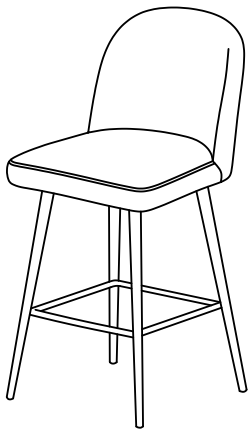

CAUTION: PINCH POINT.  
Please keep hands clear during swivel.