

CARTON A PART LIST

A Left Armrest

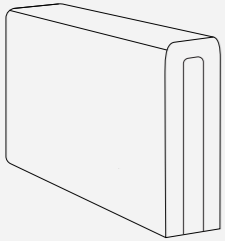

x1

B Right Armrest

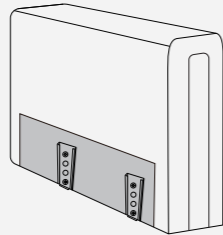

x1

1 Plastic Leg

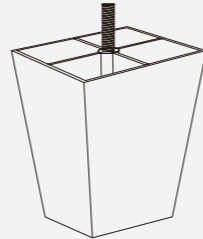

x4

2 Plastic Washer

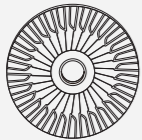

x4

CARTON A ASSEMBLY

Armrests are in carton A, Remove all parts from the carton A ,
Place them on protected surface or carpet.

Step 1:

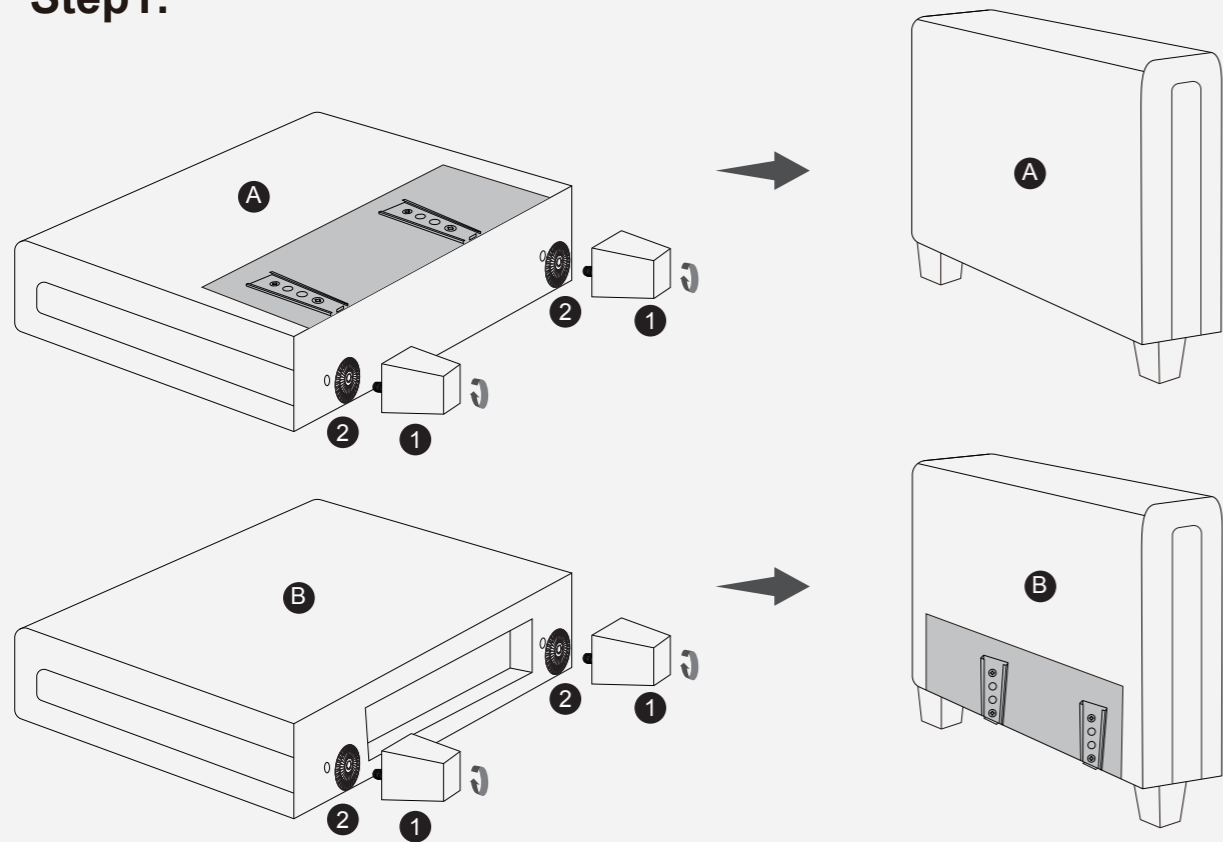

CARTON B PART LIST

C Long Seat Frame

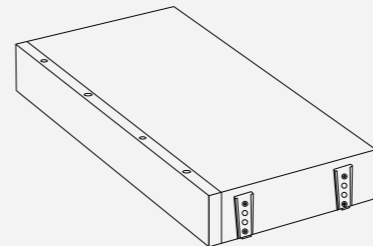

x1

D Long Back Frame

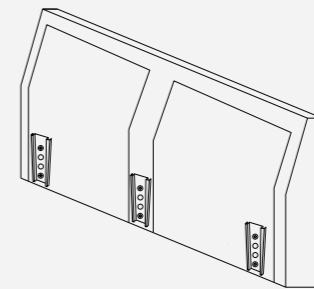

x2

E Seat Cushion

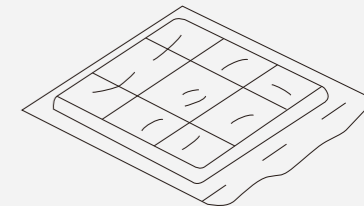

x2

F Back Pillow

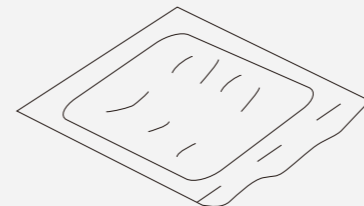

x2

1 Plastic Leg

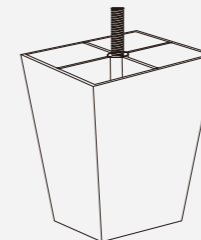

x4

2 Plastic Washer

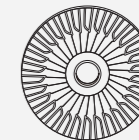

x4

4 Anti Inflation Stick

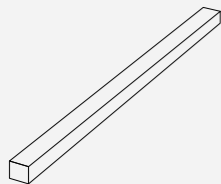

Note:The purpose of wooden strips is to prevent package expansion and not to be used in actual products.

x2

3 Assembly Instructions

x1

CARTON B ASSEMBLY

Long seat module is in carton B, Remove all parts from the carton B , Place them on protected surface or carpet.

Step1:

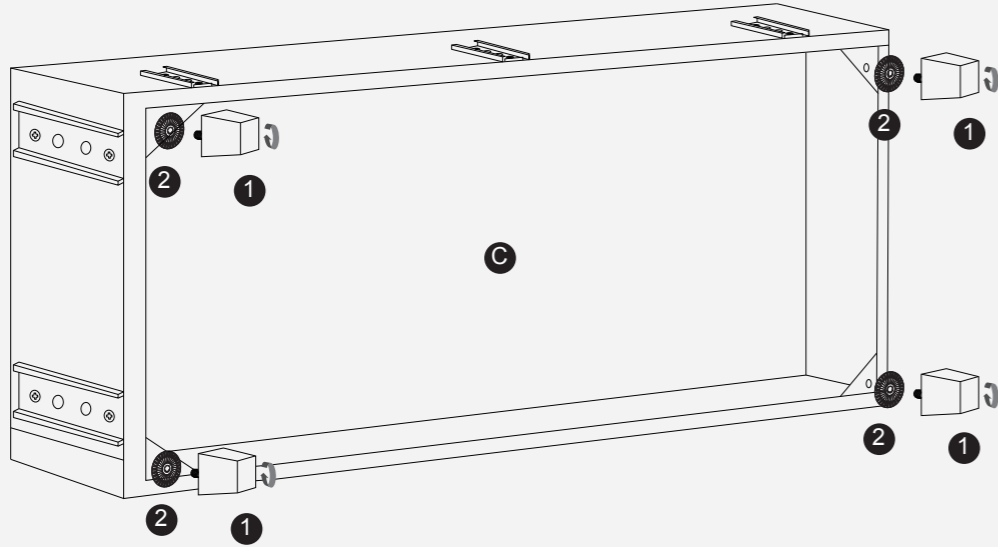

Step2: Install Back Frame to Seat Frame

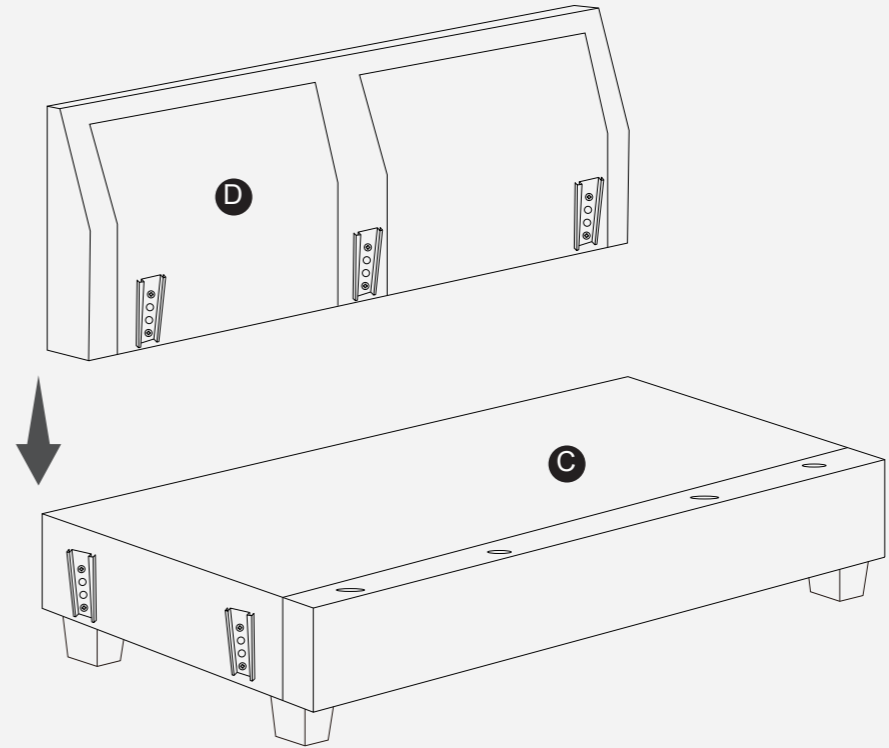

CARTON C PART LIST

G Single Seat Frame

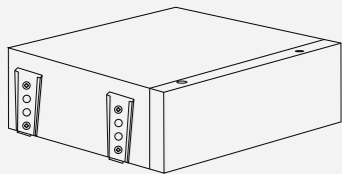

x1

H Single Back Frame

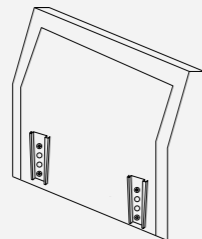

x1

E Seat Cushion

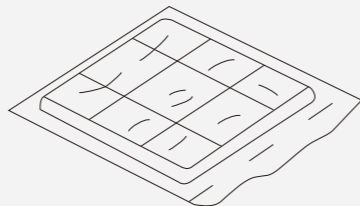

x1

F Back Pillow

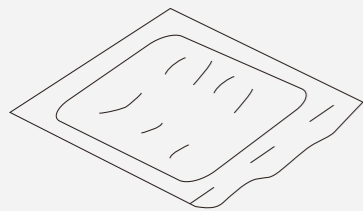

x1

2 Plastic Leg

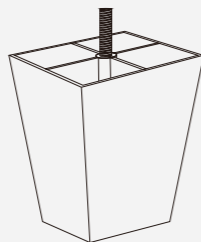

x4

3 Plastic Washer

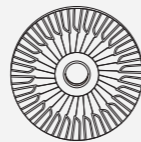

x4

CARTON C ASSEMBLY

Single seat module is in carton C, Remove all parts from the carton C ,
Place them on protected surface or carpet.

Step1:

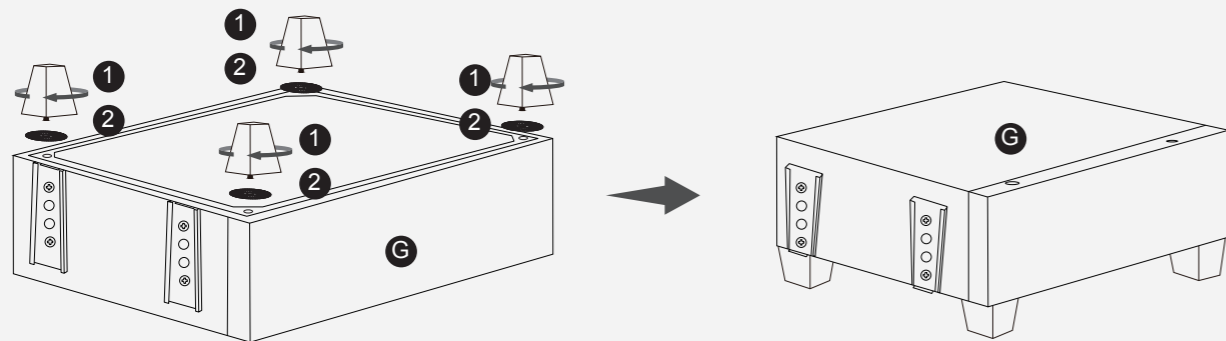

Step2: Install Single Back Frame to Single Seat Frame

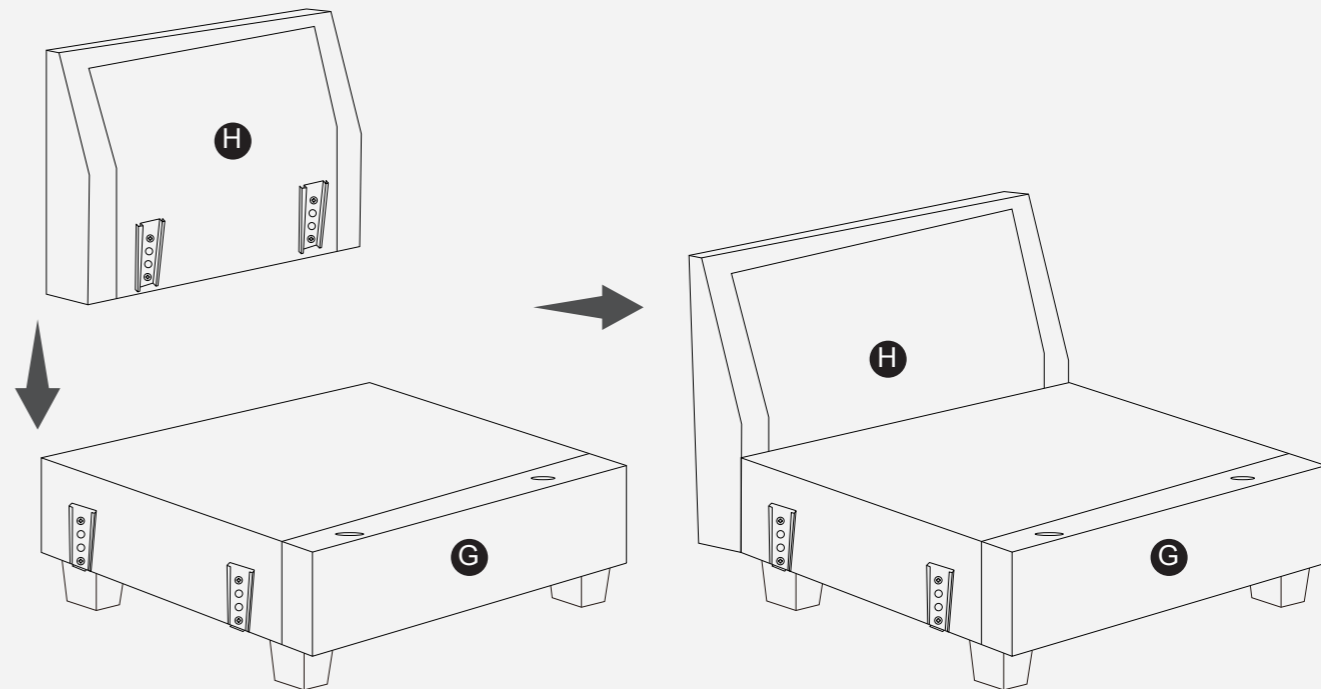

CARTON D PART LIST

J Corner Seat Frame

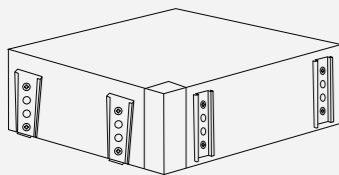

x1

K Corner Short Back Frame

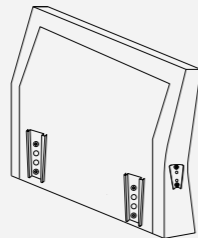

x1

L Corner Long Back Frame

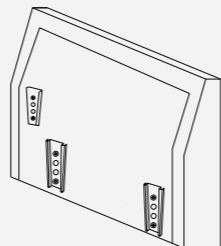

x1

M Corner Seat Cushion

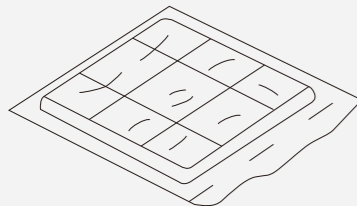

x1

N Long Corner Back Pillow

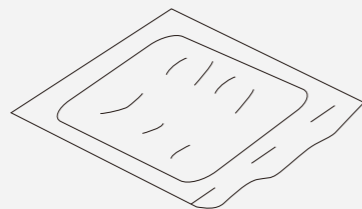

x1

P Small Corner Back Pillow

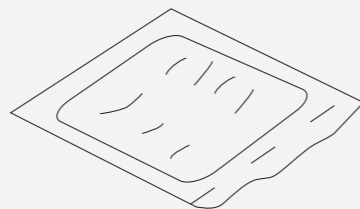

x1

3 Plastic Leg

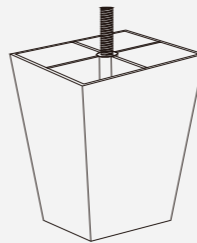

x4

3 Plastic Washer

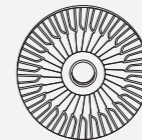

x4

CARTON D ASSEMBLY

Corner seat module is in carton D, Remove all parts from the carton D, Place them on protected surface or carpet.

Step1:

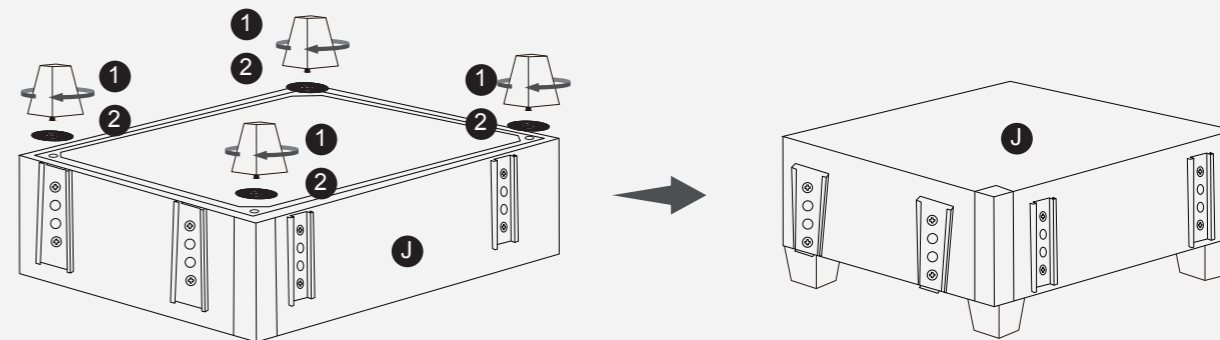

Step2: Install Corner Long Back Frame to Corner Seat Frame

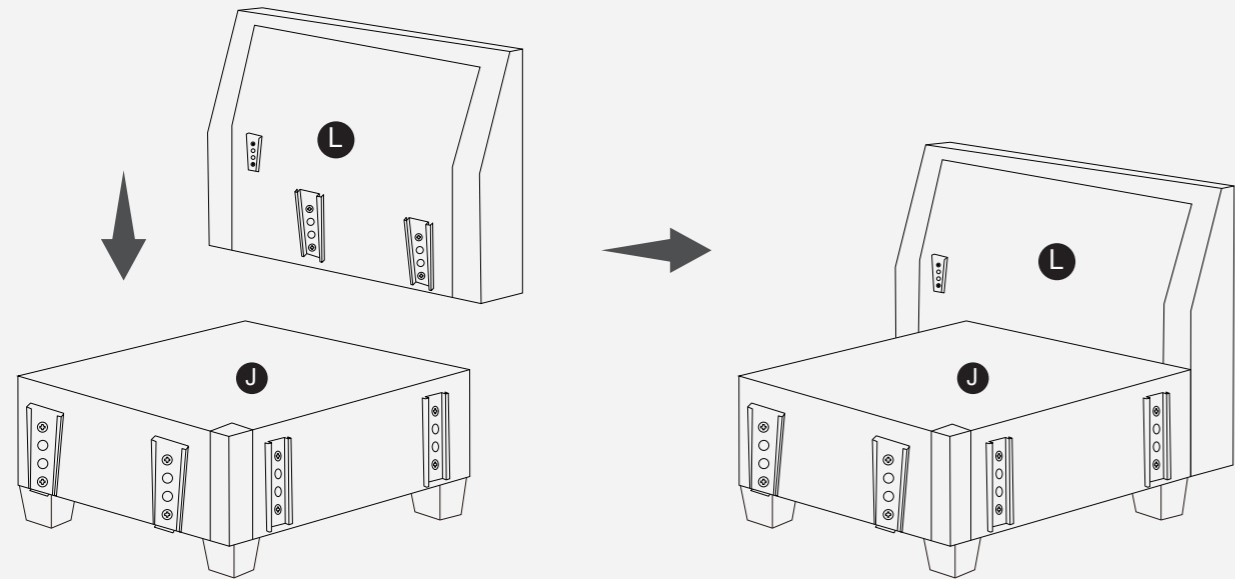

Step3: Install Corner Short Back Frame to Corner Seat Frame

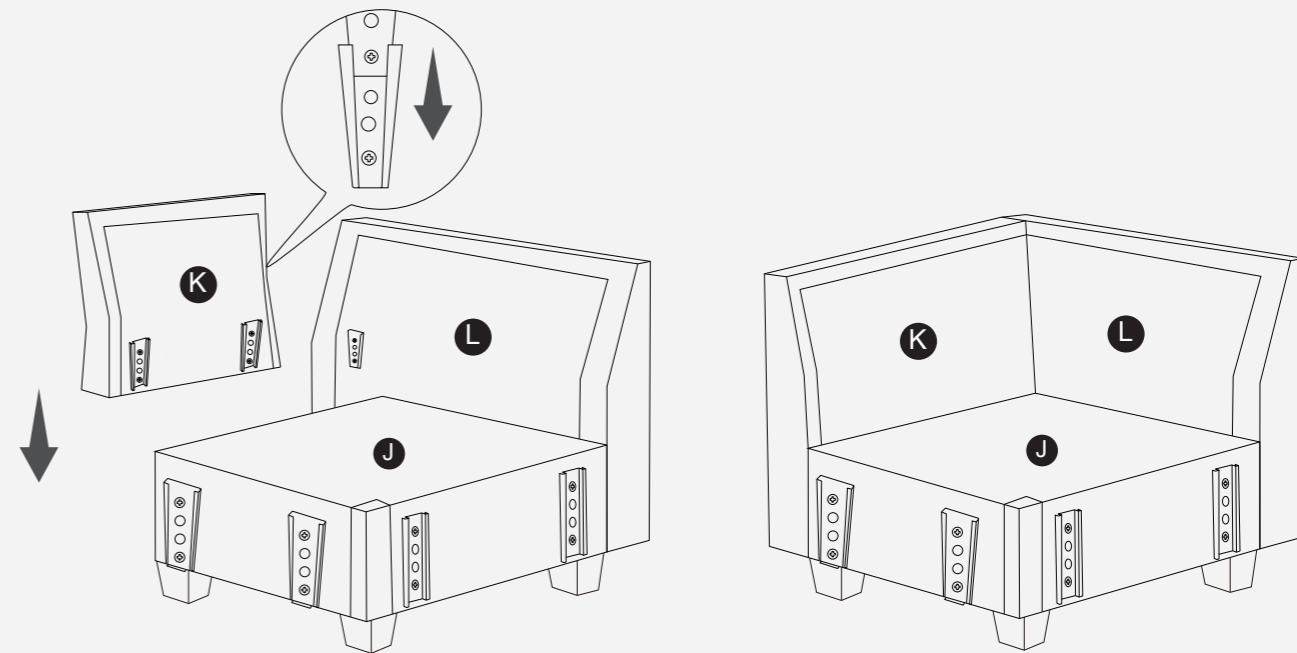

Step4:

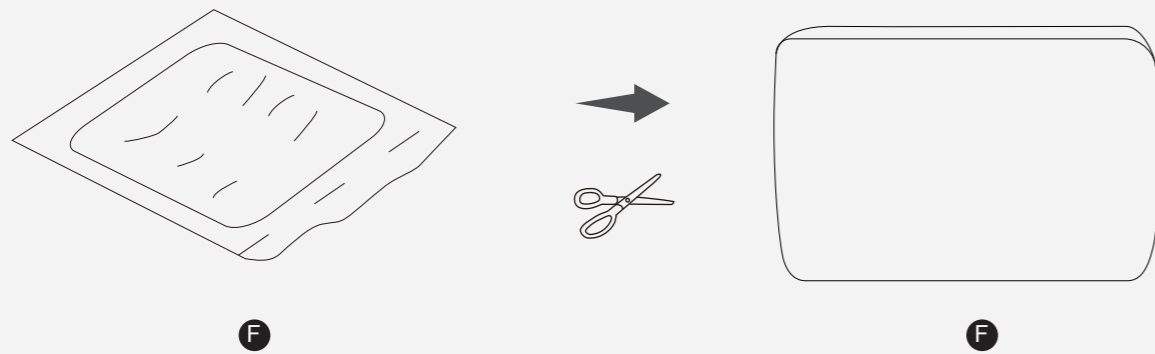
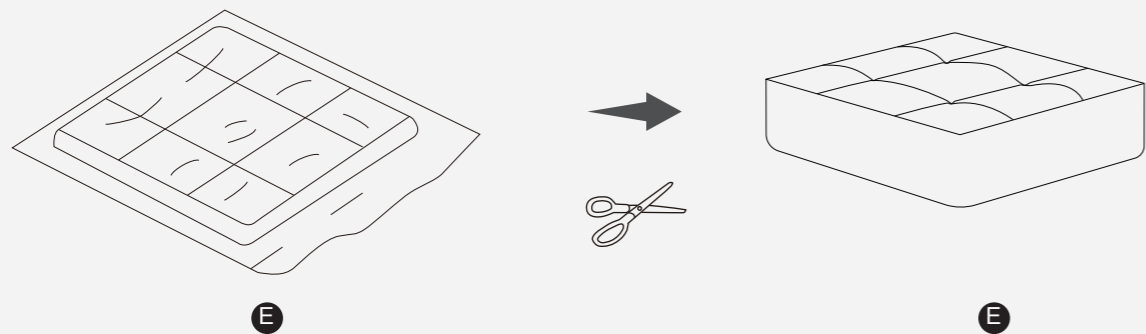

Step5:

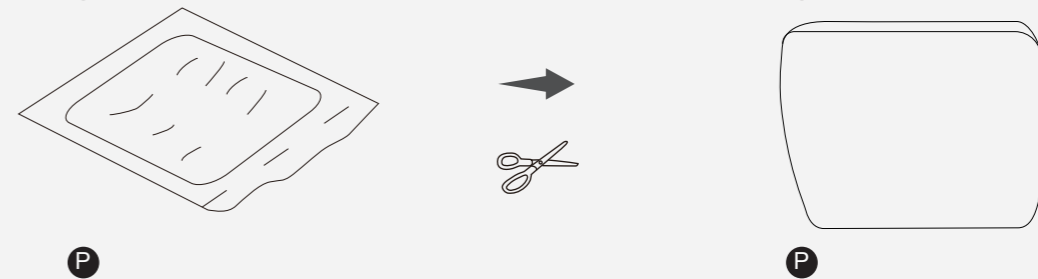
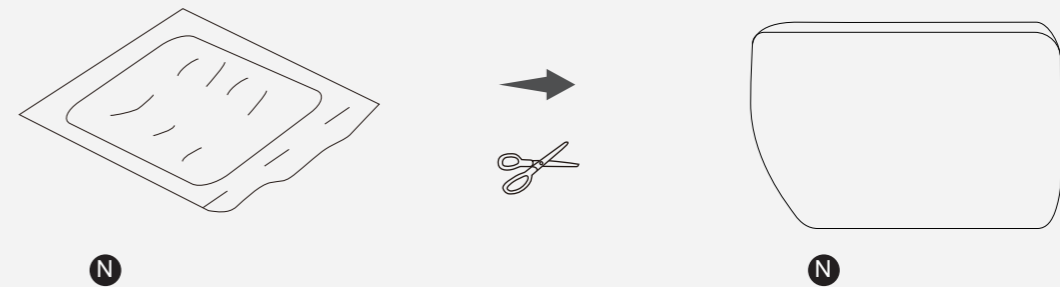
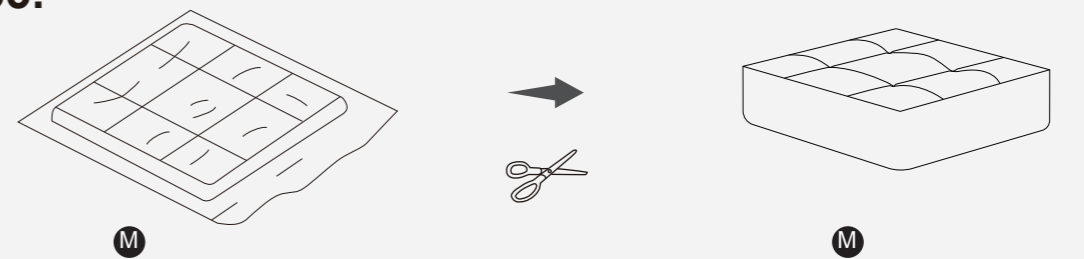

Step6:

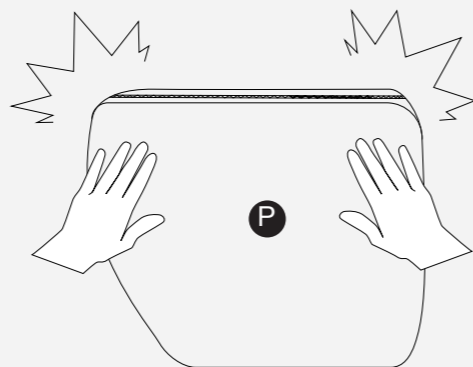
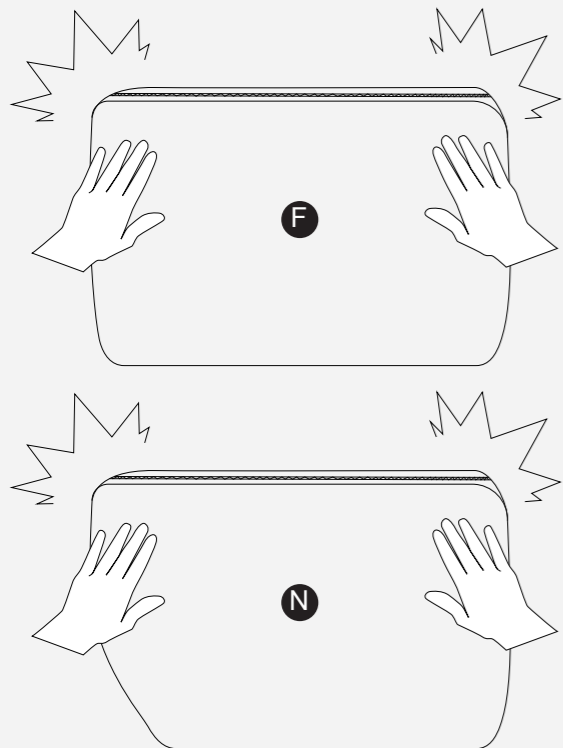

CARTON (A+B+C+D)

Step1:

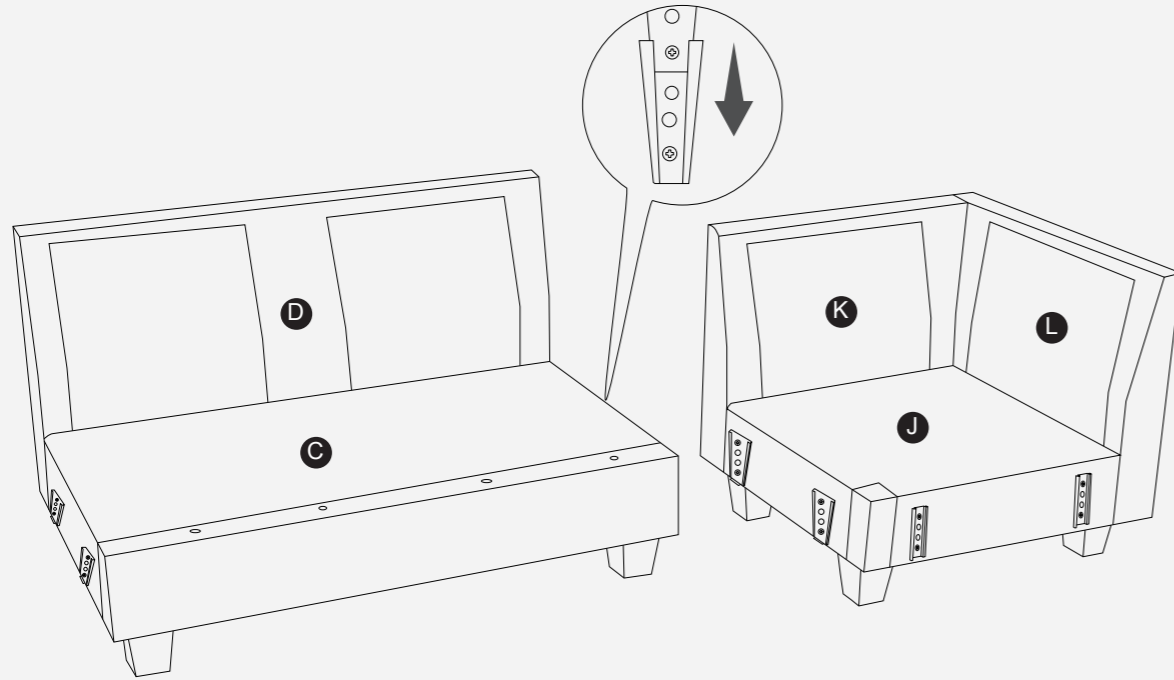

Step2:

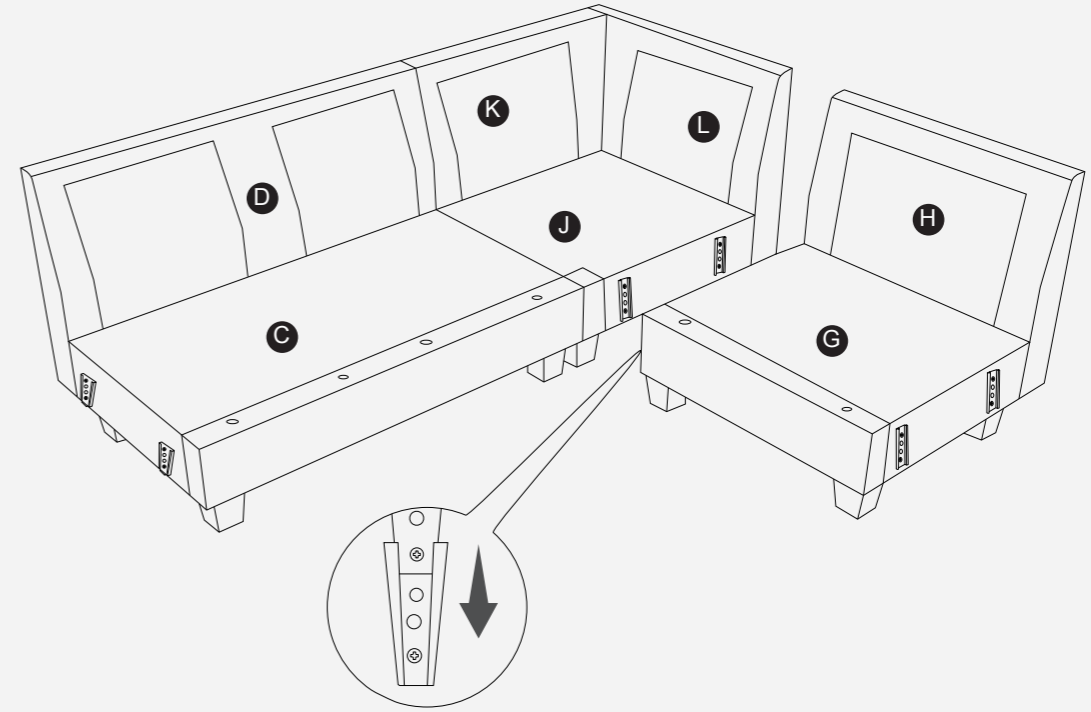

Step3: Install **A** to **C** Install **G** to **B**

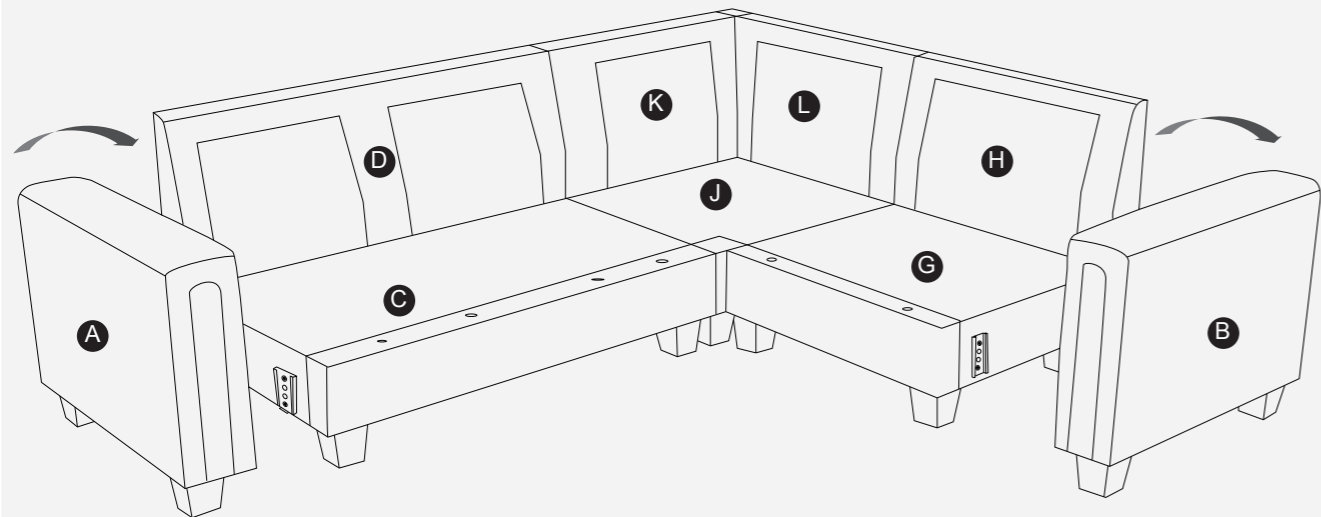

Step4:

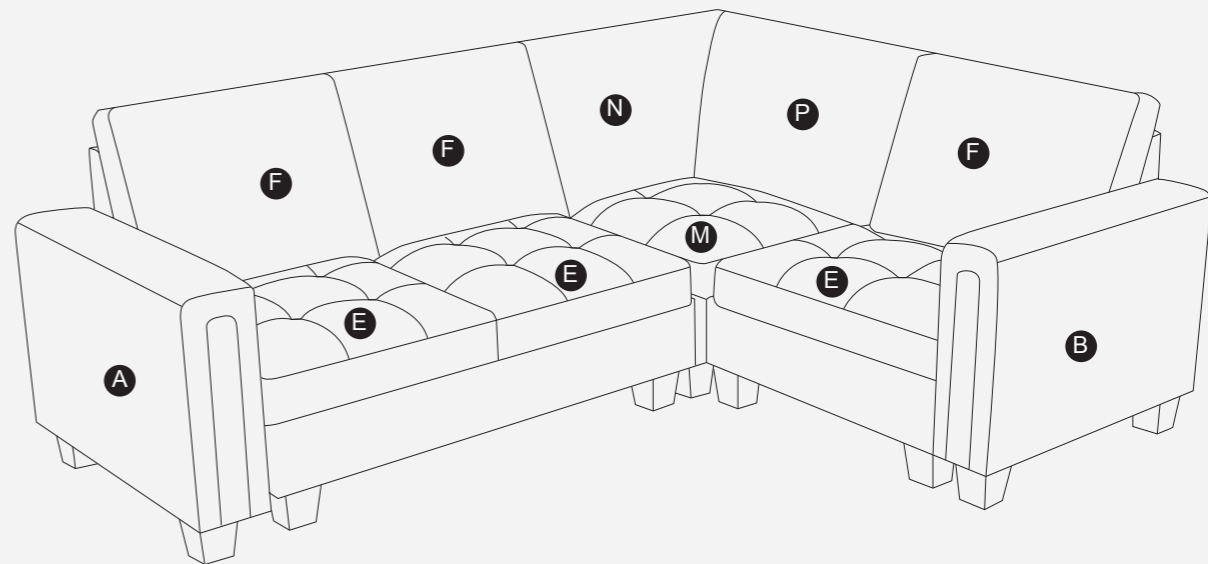

FREE COMBINATION

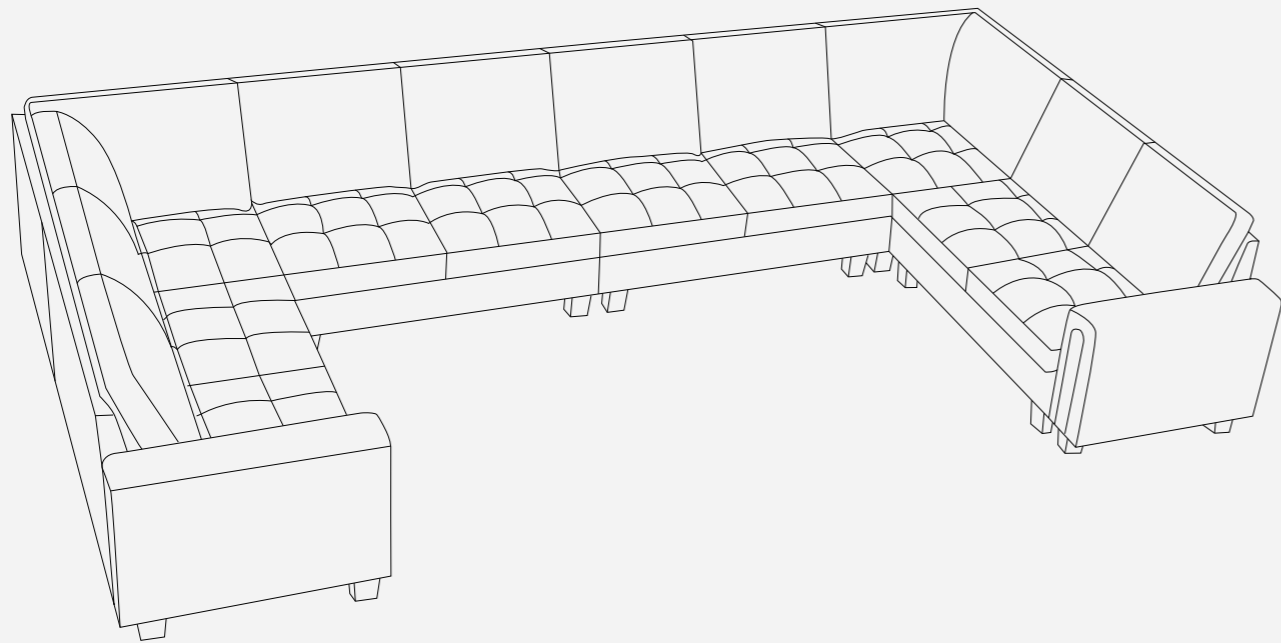

CARTON (A + 4B + 2D)

FREE COMBINATION

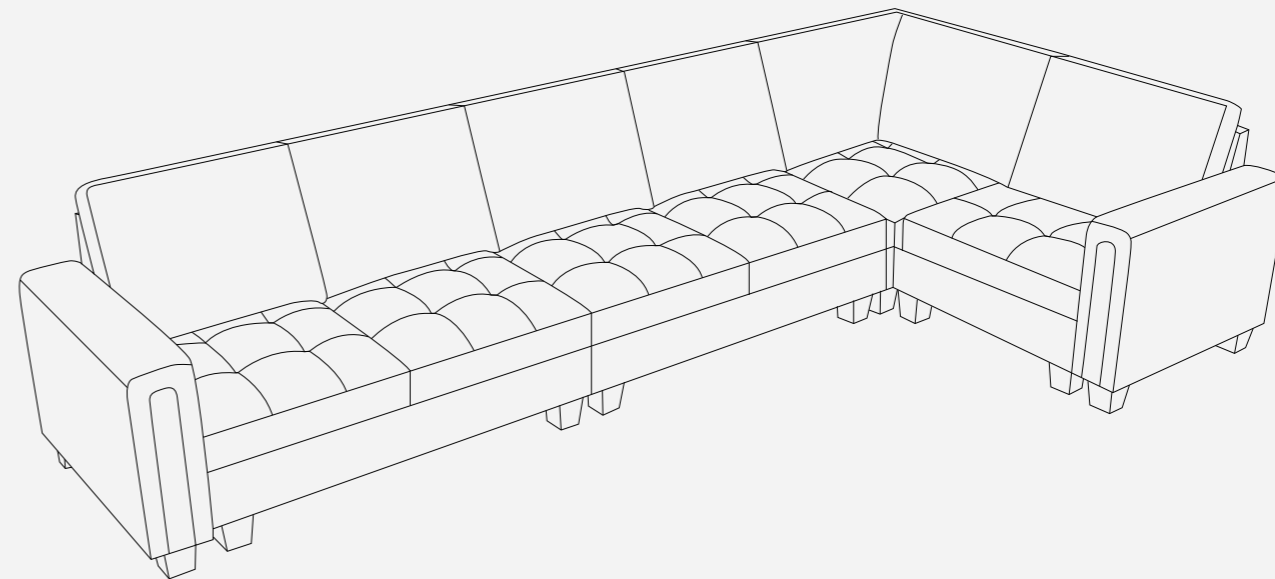

CARTON (A + 2B + C + D)