

# ASSEMBLY INSTRUCTIONS

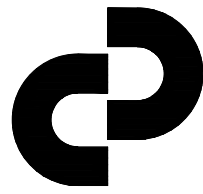

PLAYCRAFT



## COPENHAGEN 8' POOL TABLE













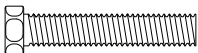

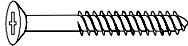

Congratulations on selecting a Copenhagen slate pool table - part of the Fairfield Collection by Playcraft. Please contact us via email at [support@playcraft.com](mailto:support@playcraft.com) should you require any assistance.

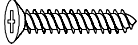
**Please carefully read all safety instructions and directions before proceeding.**

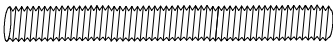
- 1) Your table is designed for use indoors in a climate controlled environment only. Damage can occur if the table is exposed to water, dampness, high humidity, freezing temperatures, etc.
- 2) Professional assembly is strongly recommended. This assembly manual is intended to guide an experienced slate pool table installer with the assembly process of this specific cabinet. It does not guide on setting the slate or attaching the billiard cloth for which the process is the same regardless of the cabinet type.
- 3) The pool table cabinet and slate are extremely heavy. Two or more people are required for assembly.
- 4) The table must be assembled in the final location where the table will be played. Attempting to move the table once assembled could result in damage to the table or serious injury.
- 5) Only use the table for its intended purpose.
- 6) Damaged or worn parts may be dangerous for users and the integrity of the table. Replace worn or damaged components immediately and do not use the table until any issues have been resolved. For best results, use only spare parts supplied by Playcraft.
- 7) Unauthorized repairs or altering the table's design or functions may be dangerous and will void the warranty.
- 8) Check all screws, bolts, etc. on a regular basis to ensure that they are in good working condition and have not loosened over time.
- 9) Over time, pool tables may require releveling. This is considered normal maintenance as required with owning a slate pool table

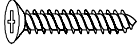
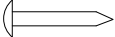

	PART #	IMAGE	DESCRIPTION	QTY
LEGS/APRONS/ BEAMS	H 1		HEX -CROSS RECESSED BOLT 5/16" x 2-3/4"	42
	H 2		FLAT WASHER 5/16" ID	50
	H 3		WOOD DOWEL Ø10mmx30mm	40
	H 4		HEX -CROSS RECESSED BOLT 3/8" x 5-1/2"	16
	H 5		FLAT WASHER 3/8" x 1"	16
RAILS / POCKETS / SLATE	H 6		SELF TAPPING PHILIP HEAD SCREW Ø1/4" x 2-1/2"	12
	H 7		METAL PLATE 4" x 3" x 1/8"	8
	H 8		HEX -CROSS RECESSED BOLT 1/4" x 3/4"	32
	H 9		FLAT WASHER 1/4" ID	32
	H 10		FLAT HEAD PHILIPS SCREW #8 x 3/4"	96
	H 11		L METAL BRACKET 5" x 1" x 1"	14
	H 12		METAL BRACKET 8-7/8" x 2-5/8" x 1/8"	2
	H 13		STUD BOLT 5/16" x 3-1/2"	4
	H 14		HEX NUT 5/16" ID	8
	H 15		DOME WASHER 3/8" ID	18
	H 16		HEX -CROSS RECESSED BOLT 3/8" x 2"	18
	H 17		FLAT HEAD PHILIPS SCREW #8 x 1/2"	12
	H 18		NAIL Ø3/16" x 1"	12
	H 19			
	H 20			
	H 21			

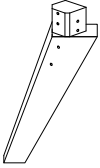
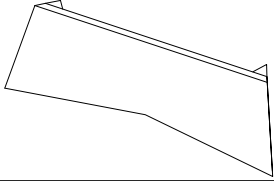
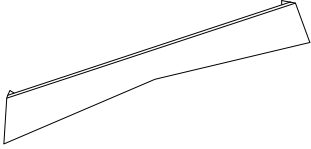
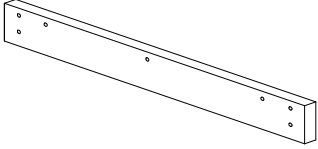
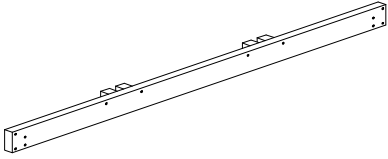
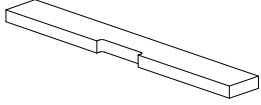
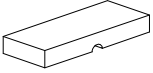
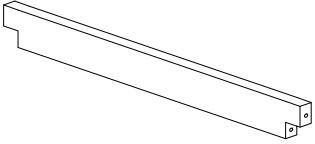
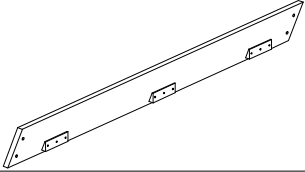
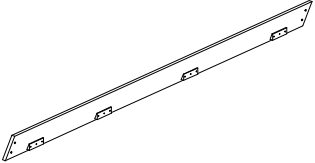

	PART #	IMAGE	DESCRIPTION	QTY
LEGS/PANEL/BEAMS	1		LEG (2L+2R)	4
	2		END PANEL	2
	3		SIDE PANEL	2
	4		END BEAM FRAME	2
	5		SIDE BEAM FRAME	2
	6		END BLOCK	2
	7		SIDE BLOCK	4
	8		CROSS BEAM	2
APRONS	9		END APRON	2
	10		SIDE APRON	2







	PART #	IMAGE	DESCRIPTION	QTY
	11		APRON CORNER	4
RAILS	12		TOP RAIL END	2
	13		TOP RAIL LEFT SIDE	2
	14		TOP RAIL RIGHT SIDE	2
POCKETS / SLATE	15		SLATE - LEFT END	1
	16		SLATE - CENTER	1
	17		SLATE - RIGHT END	1
	18		BILLIARD CLOTH	1
	19		SIDE POCKET	2
	20		CORNER POCKET	4



FIG.1

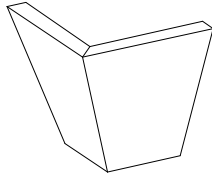
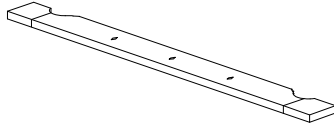
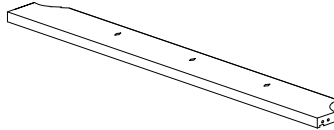
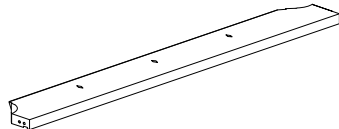
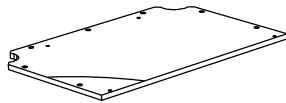
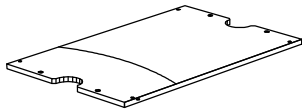
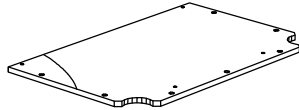
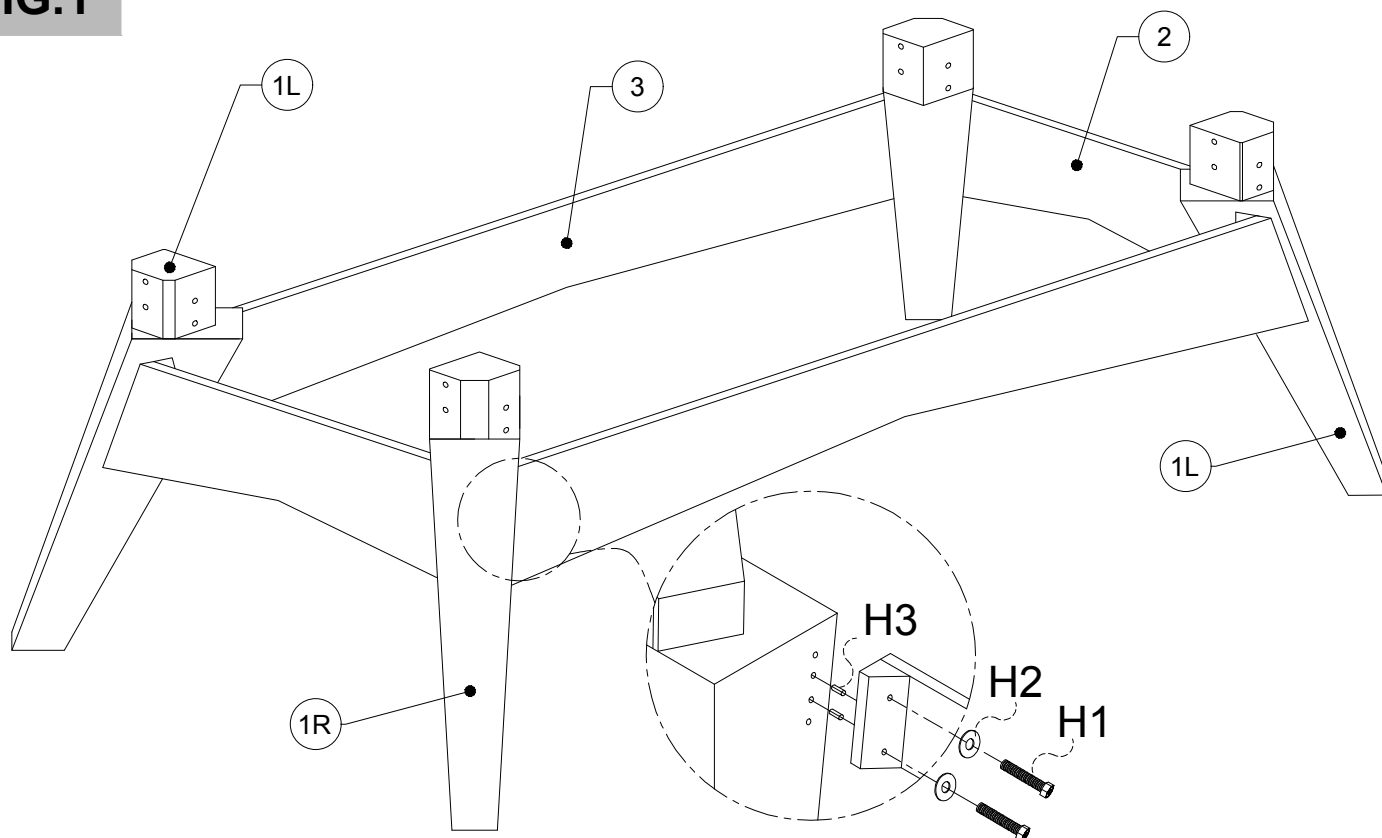

FIG.2

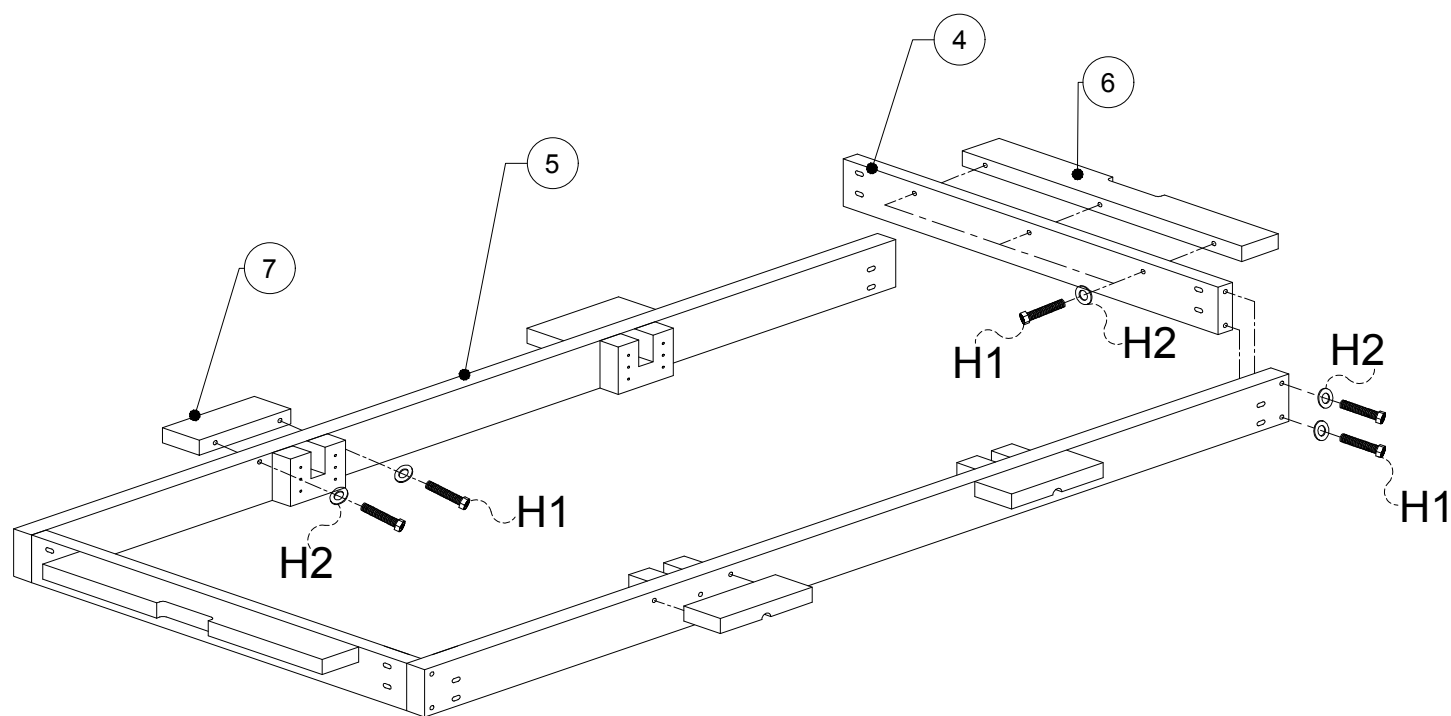



FIG.3

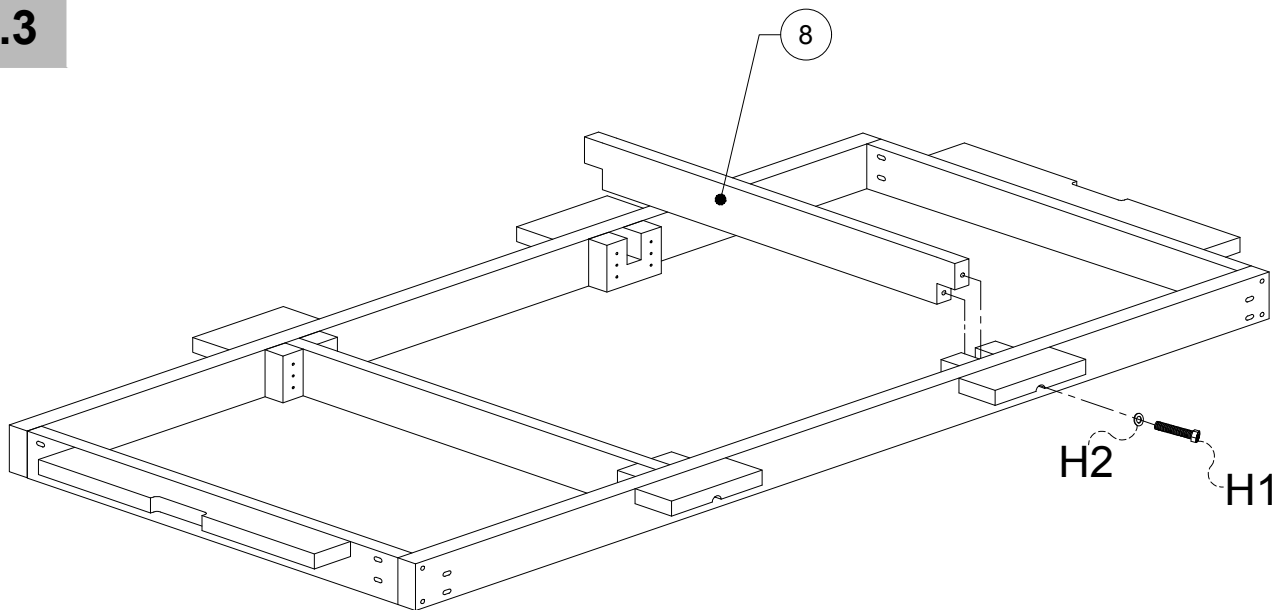

FIG.4

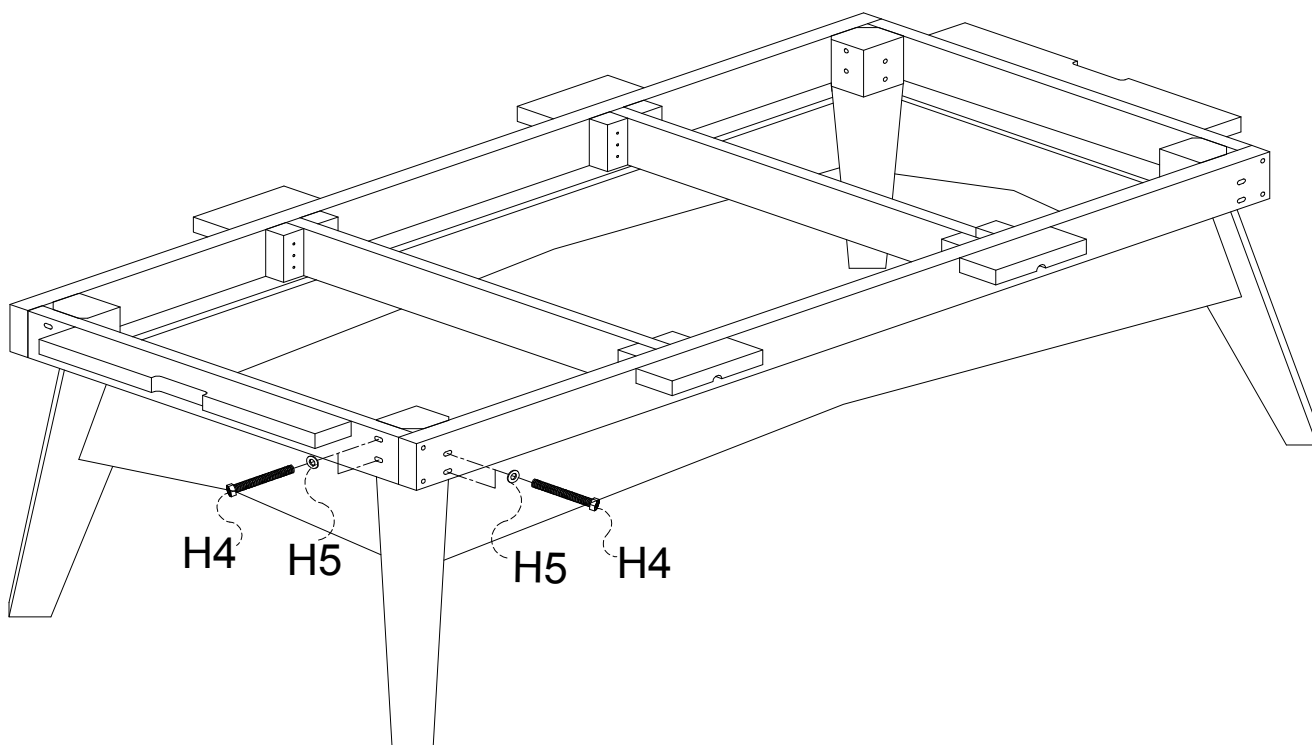



FIG.5

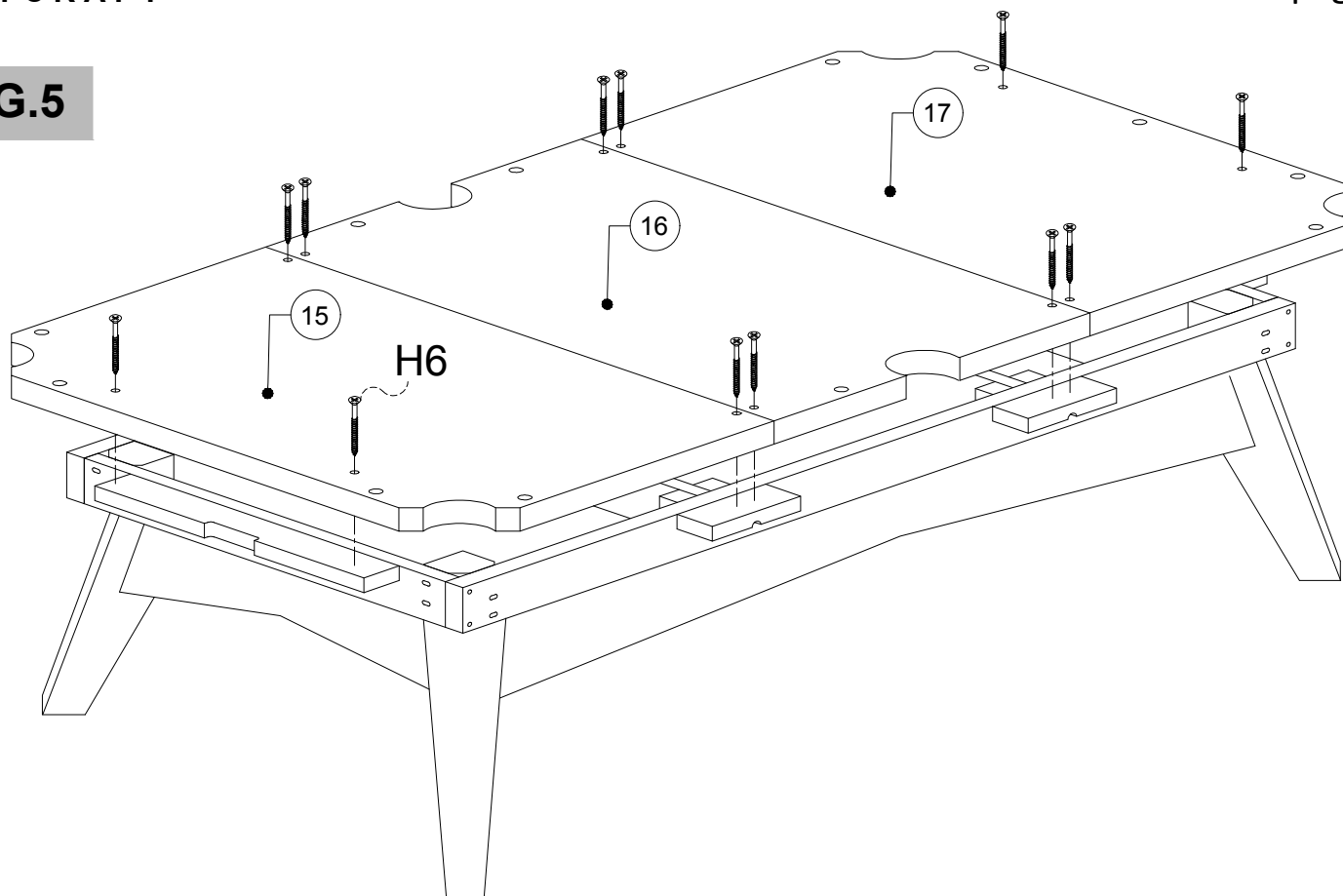
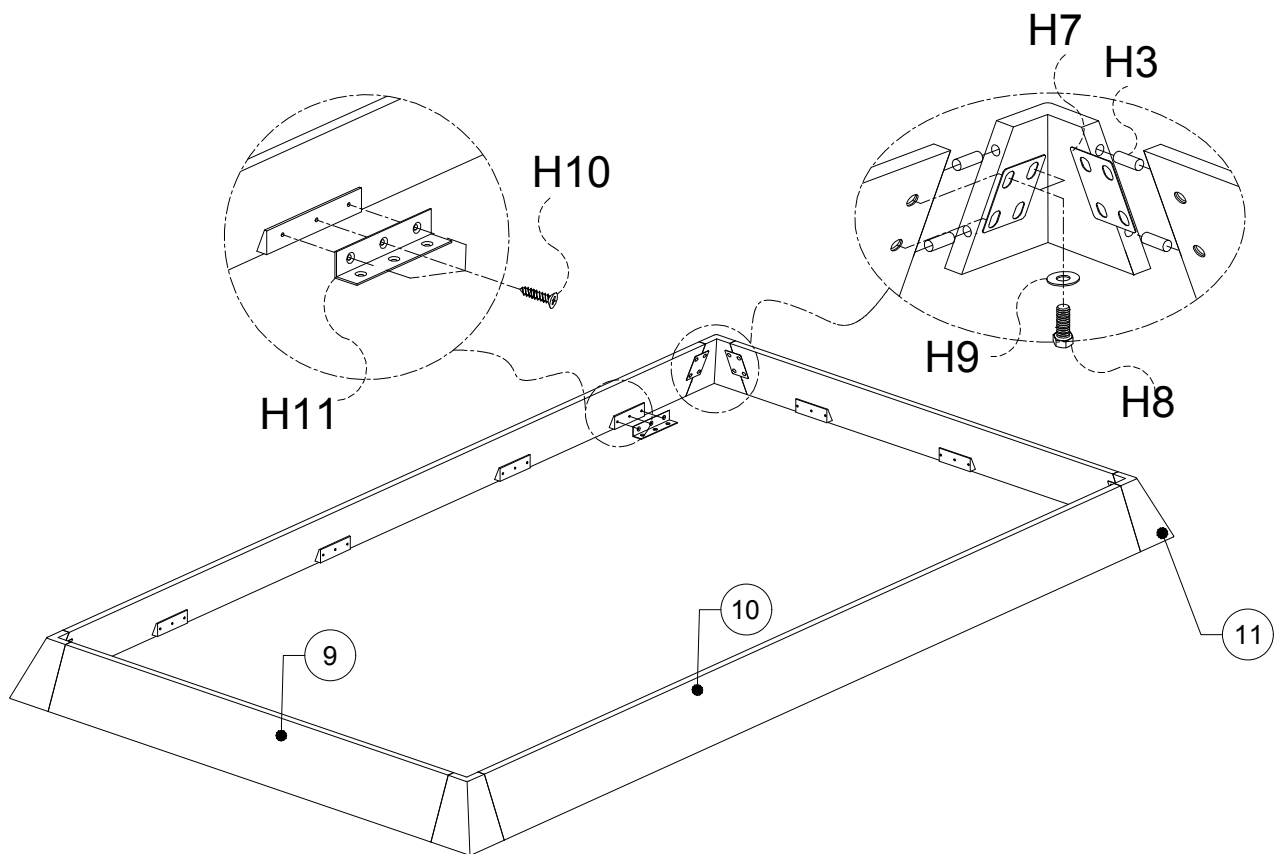
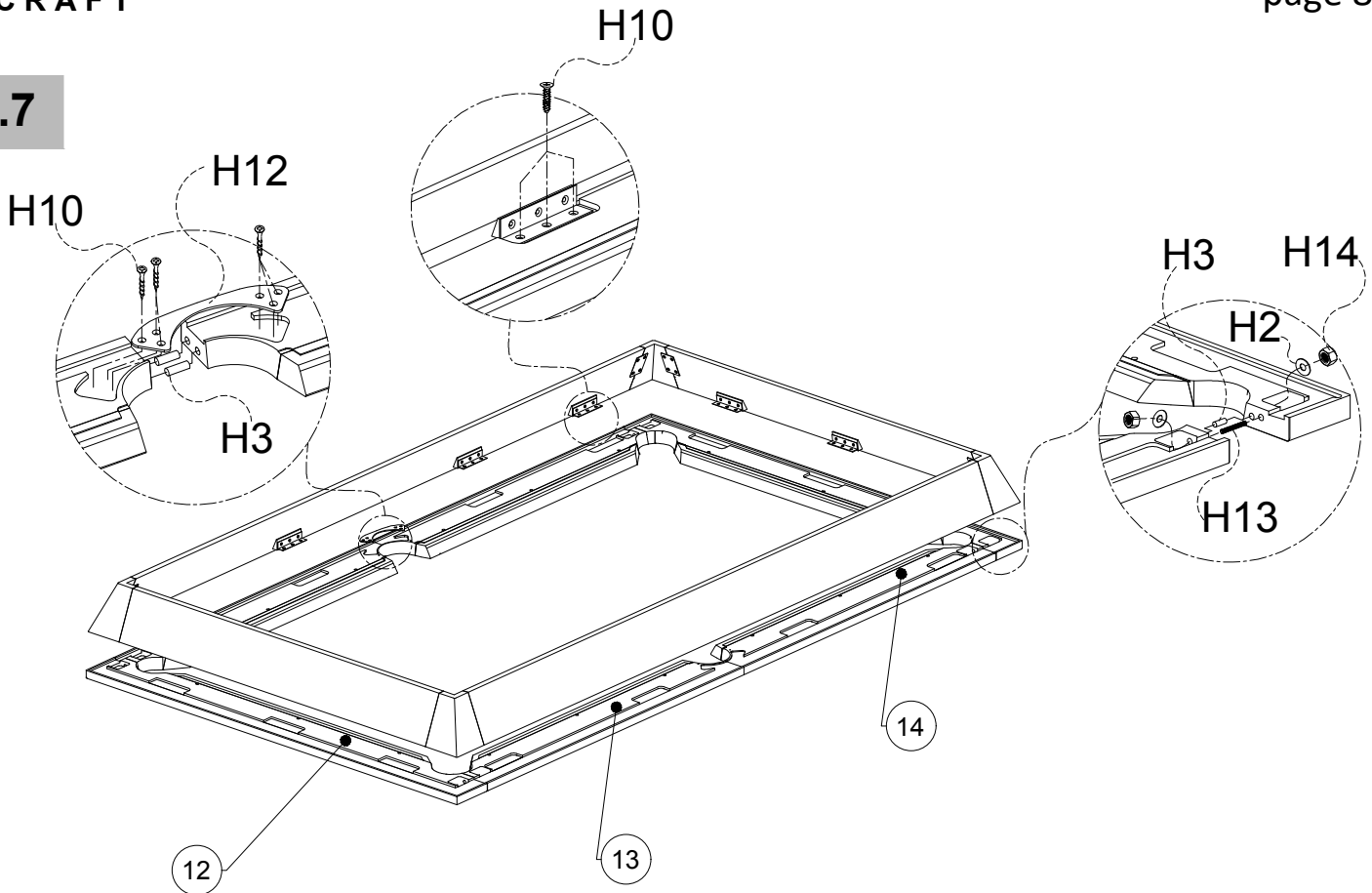

FIG.6



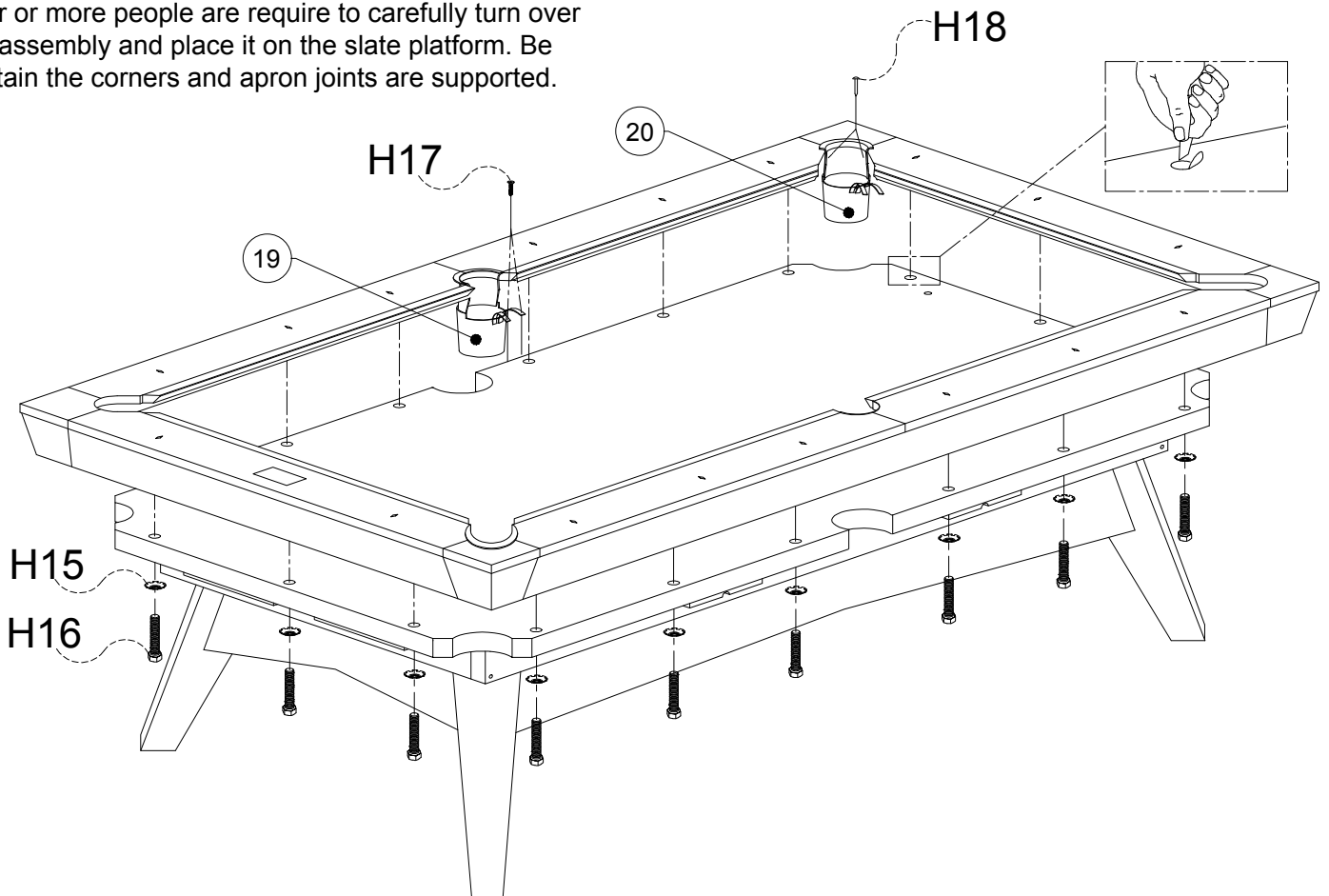

**FIG.7**



**FIG.8**

NOTE: Proceeding to the next step requires the cushions and slate bed to be covered with billiard cloth.  
Caution: The rail and apron assembly is extremely heavy.  
Four or more people are required to carefully turn over the assembly and place it on the slate platform. Be certain the corners and apron joints are supported.



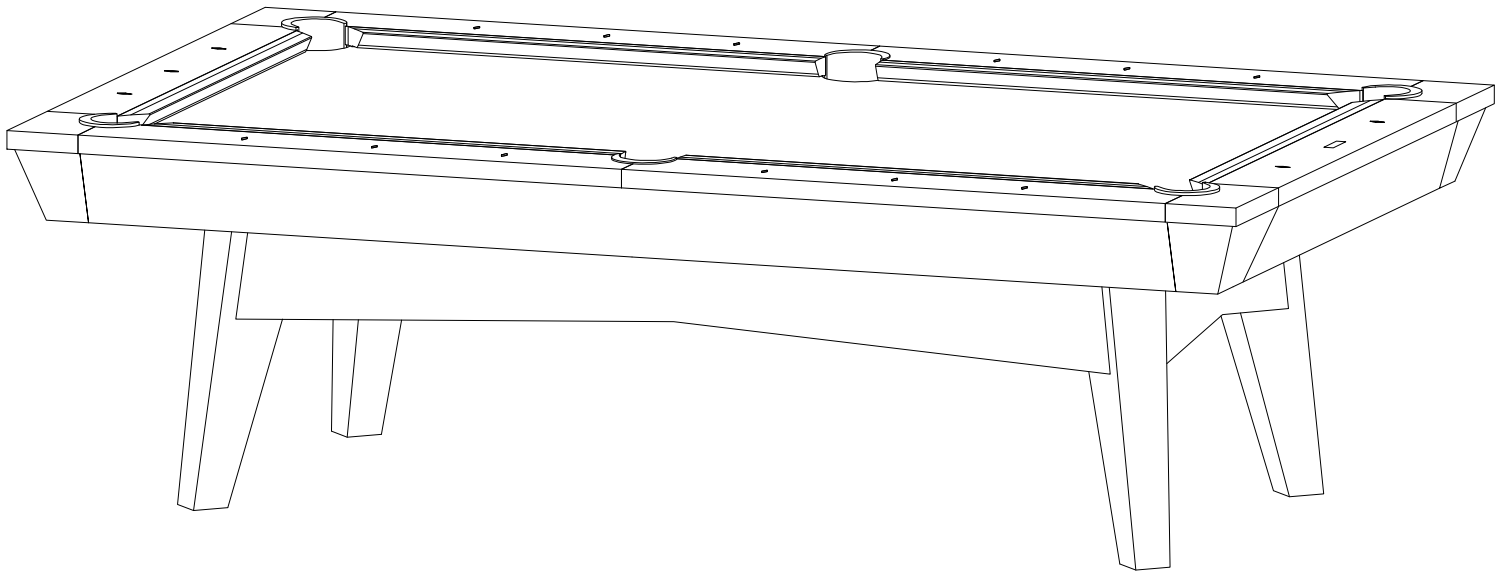

## Customer Service

For questions on assembly or for missing or damaged parts, please contact us via email at [support@playcraftf.com](mailto:support@playcraftf.com). Please visit our website at [www.playcraftf.com](http://www.playcraftf.com) to see more industry leading Playcraftf and Playcraftf Sport game tables.

**Thank you for choosing Playcraftf!**

Global Merchants, Inc.  
12 Lunar Drive  
Woodbridge, CT 06525