

# ASSEMBLY INSTRUCTIONS

## 5pcs Pack Counter Height Set Black Finish

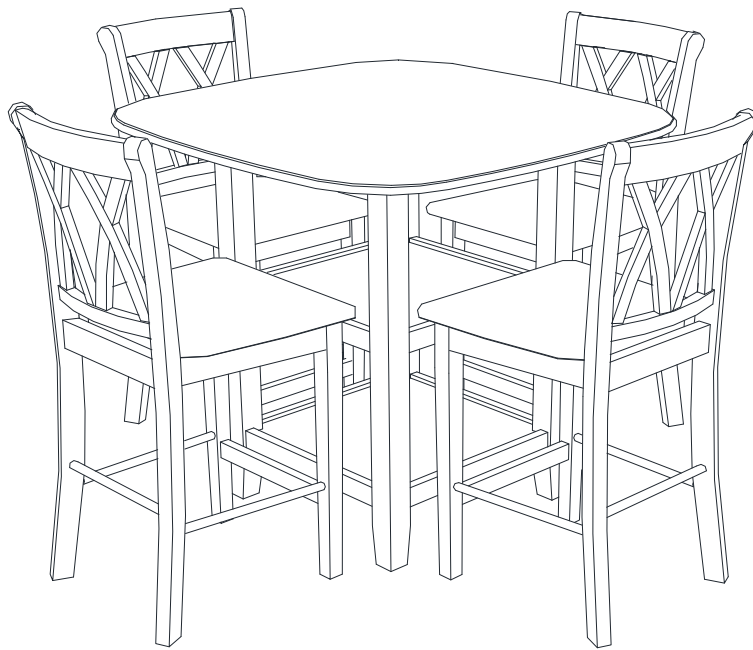





This page lists all the contents included in the box. Please take time to identify the hardware as well as the individual components to this product. As you unpack and prepare for assembly, place the contents on a carpeted or padded area to protect them from damage.

**cleaning & care** Treat surface with care. Clean surfaces with a dry or damp soft cloth. Do not use abrasive cleaners. Hardware may loosen over time. Periodically check that all connections are tight.

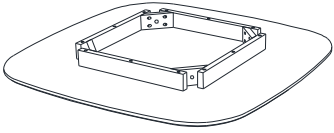
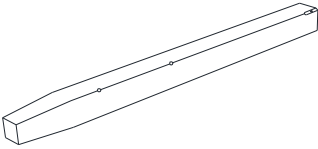
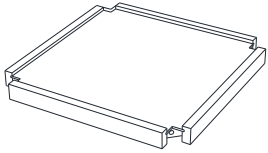
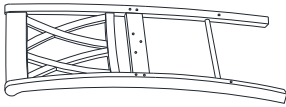
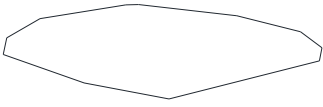
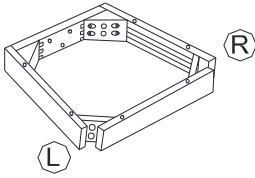
A Phillips head screwdriver is necessary for assembly.

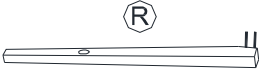
# PART LIST

<p><b>A</b></p> 	<p><b>B</b></p> 
<p>TABLE TOP 1 PC</p>	<p>TABLE LEG 4 PCS</p>
<p><b>C</b></p> 	<p><b>D</b></p> 
<p>TABLE SHELF 2 PCS</p>	<p>CHAIR BACK 4 PCS</p>
<p><b>E</b></p> 	<p><b>F</b></p> 
<p>CUSHION 4 PCS</p>	<p>CHAIR SEAT FRAME 4 PCS</p>
<p><b>G</b></p> 	<p><b>H</b></p> 
<p>CHAIR FRONT LEFT LEG 4 PCS</p>	<p>CHAIR FRONT RIGHT LEG 4 PCS</p>
<p><b>I</b></p> 	<p><b>J</b></p> 
<p>CHAIR FRONT CROSSBAR 4 PCS</p>	<p>SIDE CROSSBAR 8 PCS</p>

### STEP 1

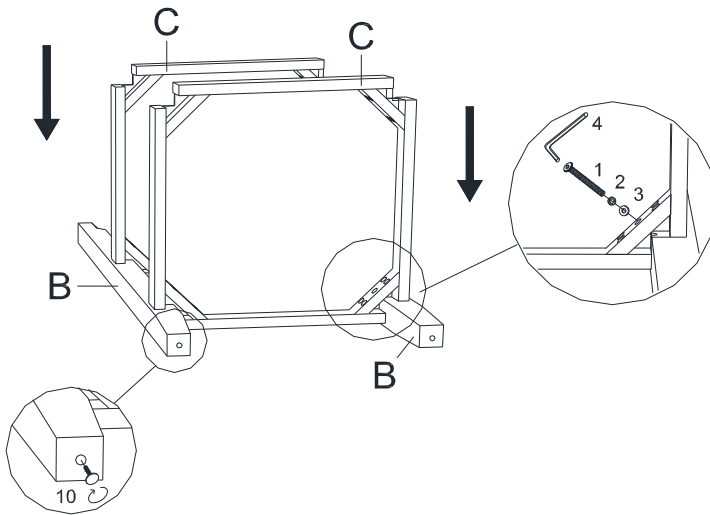

REQUIRED HARDWARE IN THIS STEP			
NO.	DESCRIPTION	SKETCH	QTY
1.	ALLEN BOLT		4 PCS
2.	SPRING WASHER		4 PCS
3.	FLAT WASHER		4 PCS
4.	ALLEN WRENCH		1 PC
10.	LEVELER		2 PCS

Attach table shelf (C) to the table legs (B) using Allen bolts (1), spring washers (2) and flat washers (3) as shown. **Don't tighten all Allen bolts at this step.**

Attach levelers (10) into the pre-drilled holes on the bottom of the legs (B).

### STEP 2

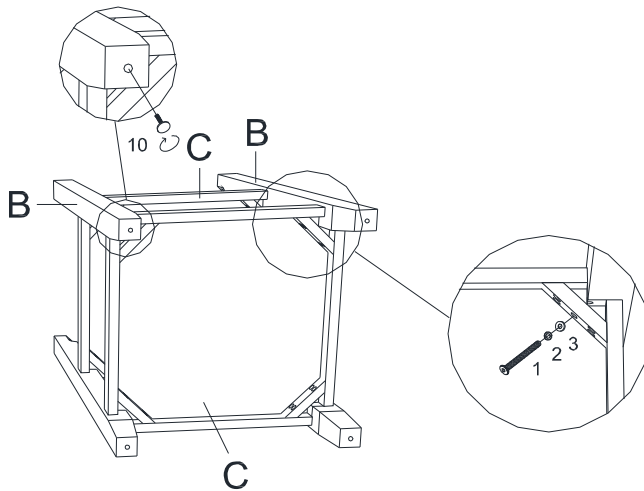

REQUIRED HARDWARE IN THIS STEP			
NO.	DESCRIPTION	SKETCH	QTY
1.	ALLEN BOLT		4 PCS
2.	SPRING WASHER		4 PCS
3.	FLAT WASHER		4 PCS
4.	ALLEN WRENCH		1 PC
10.	LEVELER		2 PCS

Attach table legs (B) to the table shelf (C) using Allen bolts (1), spring washers (2) and flat washers (3) as shown. **Don't tighten all Allen bolts at this step.**

Attach levelers (10) into the pre-drilled holes on the bottom of the legs (B).



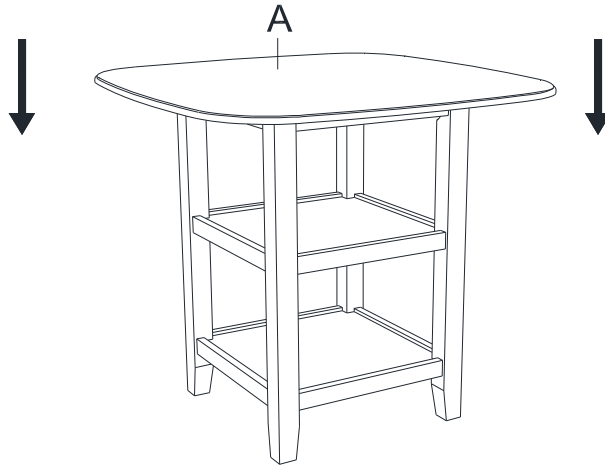

### STEP 3

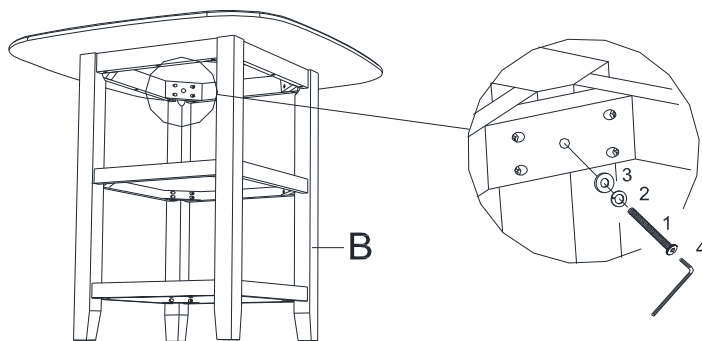

Turn the assembly upright. Place table top (A) down to the assembly unit as shown, making sure table legs secure into top.

### STEP 4



REQUIRED HARDWARE IN THIS STEP			
NO.	DESCRIPTION	SKETCH	QTY
1.	ALLEN BOLT		4 PCS
2.	SPRING WASHER		4 PCS
3.	FLAT WASHER		4 PCS
4.	ALLEN WRENCH		1 PC

Attach table legs (B) to table top (A) using Allen bolt (1), spring washer (2) and flat washer (3) as shown.

Make sure the table is level, and tighten all Allen bolt (1) by Allen wrench.

## STEP 5



Turn the table upright.  
The table is now ready for use

## STEP 6

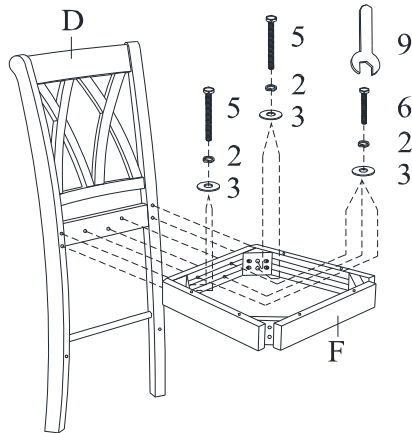

REQUIRED HARDWARE IN THIS STEP			
NO.	DESCRIPTION	SKETCH	QTY
2.	SPRING WASHER		7 PCS
3.	FLAT WASHER		7 PCS
9.	OPEN WRENCH		1 PC
5.	LONG BOLT		4 PCS
6.	SHORT BOLT		3 PCS

Attach seat frame (F) to chair back frame (D) using short bolts (6), long bolts (5), spring washers (2) and flat washers (3) as shown. Do not tighten the bolts in this step.

Note: Seat frame (F) has holes on each side. These holes are to attach the seat board (E) in the next step. Ensure that the wider end of the holes face down towards the ground.



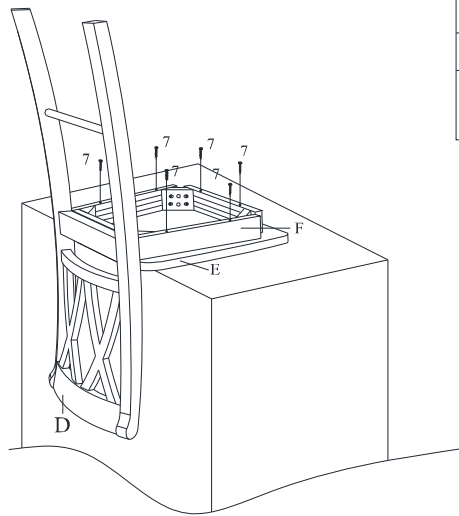

## STEP 7



REQUIRED HARDWARE IN THIS STEP			
NO.	DESCRIPTION	SKETCH	QTY
7.	WOOD SCREW		6 PCS

Place seat board (E) upside down on a clean smooth surface. Attach assembled chair frame to the seat board (E) with wood screw (7) using a Phillips head screw driver (not included).

# STEP 8

REQUIRED HARDWARE IN THIS STEP			
NO.	DESCRIPTION	SKETCH	QTY
8.	NUT		4 PCS
2.	SPRING WASHER		4 PCS
3.	FLAT WASHER		4 PCS
9.	OPEN WRENCH		1 PC
7.	WOOD SCREW		6 PCS

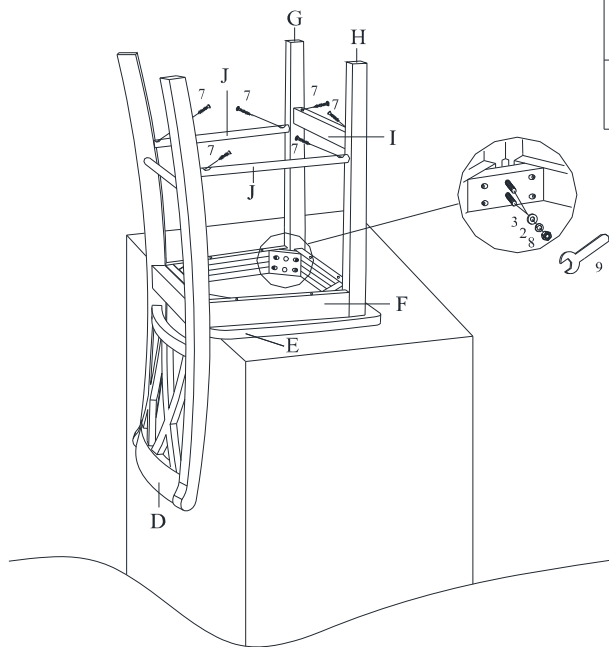

Attach chair left and right front legs (G & H) to seat frame (F) with flat washers (3), spring washers (2), and nuts (8) as shown. Do not fully tighten nuts (8). Insert chair left side crossbar and chair right side crossbar (J) into the front left and right chair legs (G & H) and chair back frame (D).

Note: The small holes on all the crossbars must face towards the ground (when chair in the normal use position).

Tighten all nuts previously installed with wrench (9). Secure the front crossbar (I), chair left side crossbar (J) and chair right side crossbar (J) to the chair legs using wood screws(7) and a Phillips head screw driver (not included) as shown below.

## STEP 9

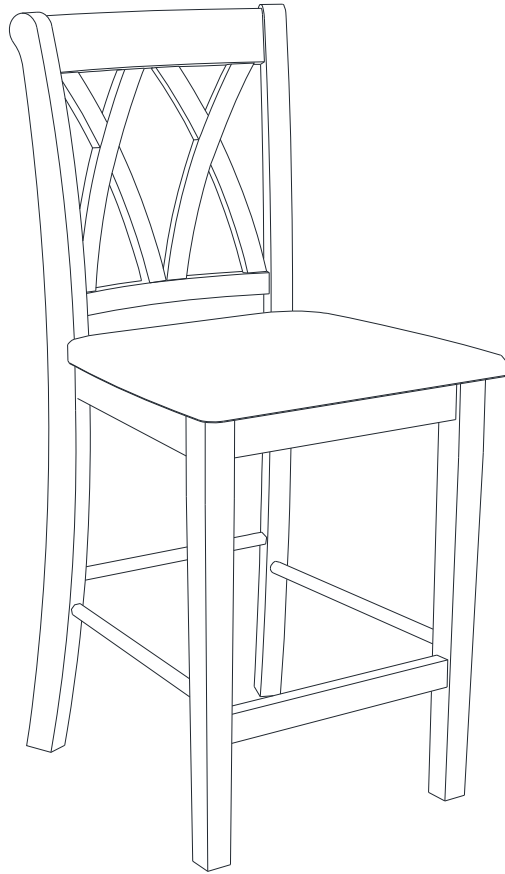

Turn the chair upright.  
The chair is now ready for use

Repeat Step 6-8 to assemble the remaining chairs.