

# Instruction Manual

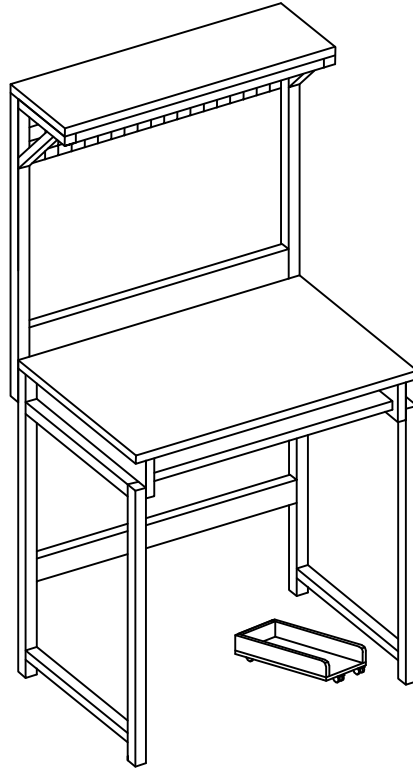

DEAR CUSTOMER,

Thank you for choosing our product. Please read this manual carefully before assembling. If the product is passed on to the third party, this manual has to be passed on along with the product. Enjoy your new purchase!



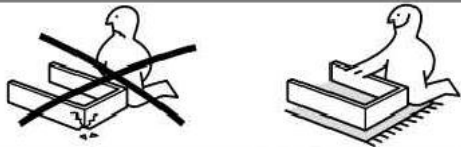

Assemble Item On a Clean Flat Surface

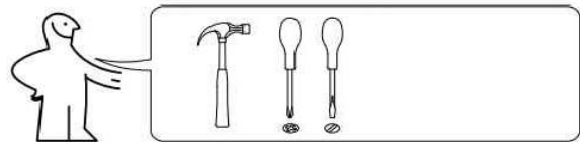







Tools Required For Assembly









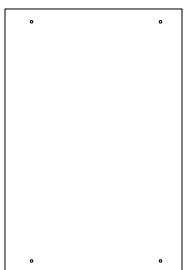
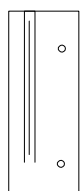
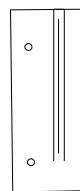

## HARDWARE LIST

1		2		3	(M6*35) 	4	(M6* 30) 	5	
	×4pcs		×4pcs		×4pcs		×12pcs		×8pcs

6  ×4pcs	7  ×4pcs	8  ×20pcs	9  ×7pcs	10  ×2pcs	11  ×4pcs
---	---	--	---	--	--

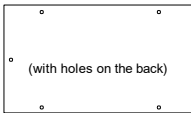
## PARTS LIST

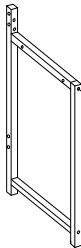
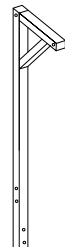

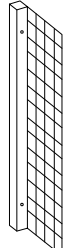
Note: there will be some error in the measurement, the actual size shall prevail.

A  ×1pc	B  ×1pc	C  ×1pc	D  ×1pc		
E  ×1pc	F  ×1pc	G  ×1pc	H  (with holes on the back) ×1pc		
I  (There are two holes here) ×2pc	J  (There are holes on three sides) ×1pc	K  ×2pc	L  ×2pcs	M  ×1pc	N  ×1pc

## NOTE

- Please check that you have all the parts and hardware listed before assembling.
- Please do not tighten all bolts until the table is assembled completely.
- If you find that something is missing, please contact the store you purchase immediately.
- At least every 4 months, check all bolts, screws and knobs to be sure they are tight.

# Screws Installation Steps

1  ×4pcs	2  ×4pcs
--	--

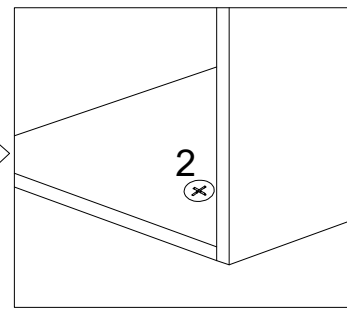
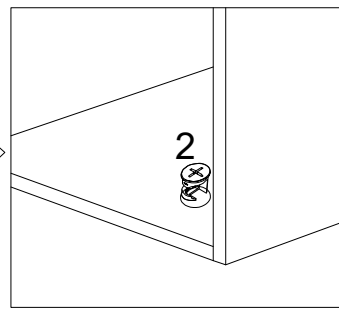
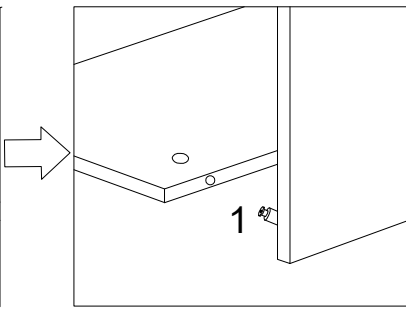
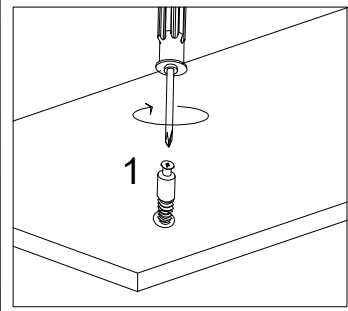



Screw the eccentric screw onto the board.

Find the corresponding board to insert.

Insert eccentric bolt into round hole.

Turn clockwise about 180° to lock the board.

# Guide rail installation drawing

8  ×20pcs	10  ×2pcs
--	--

Align the track with the position of the drawer and screw in.

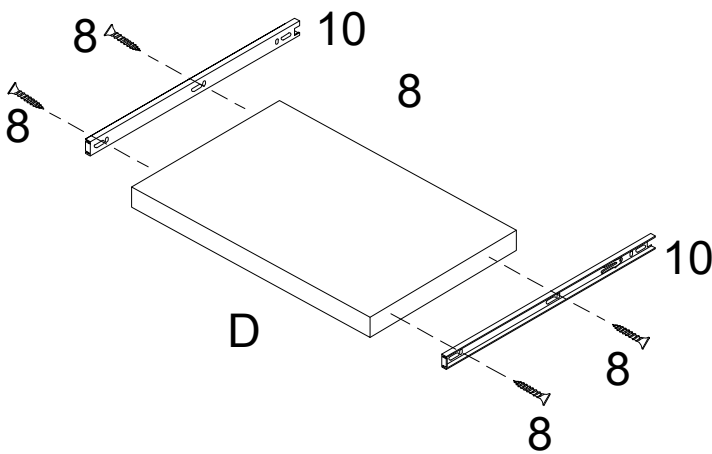

The track on the drawer is directly pushed into the track on the cabinet body, and the installation is completed.

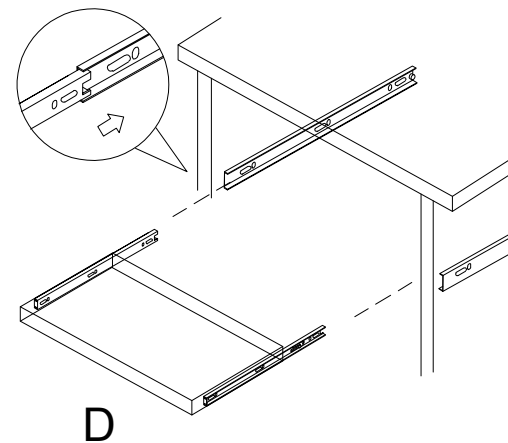

### Step:1

4 (M6\*30)  
×12pcs

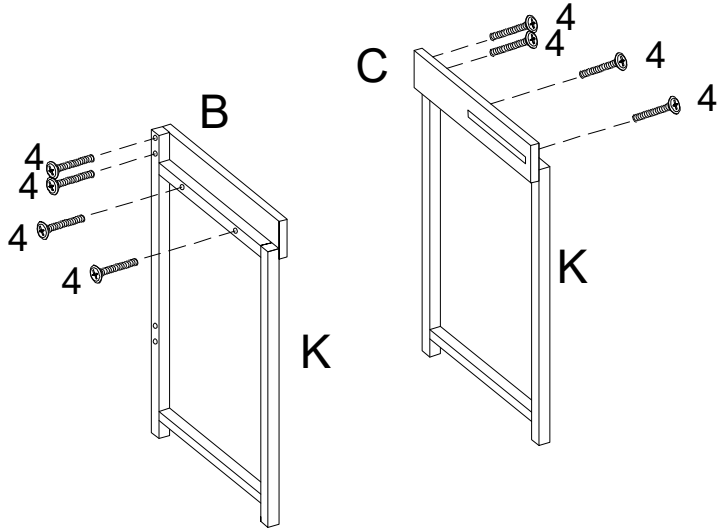

Connect panel B,C .

### Step:2

5  
×8pcs

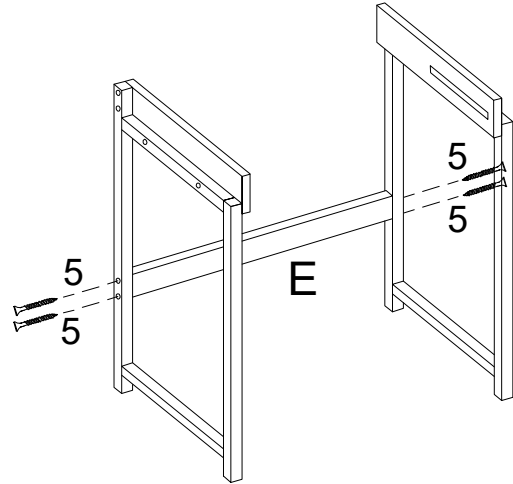

Connect panel E .

1 ×4pcs	2 ×4pcs	8 ×24pcs	10 ×2pcs
------------	------------	-------------	-------------

### Step:3

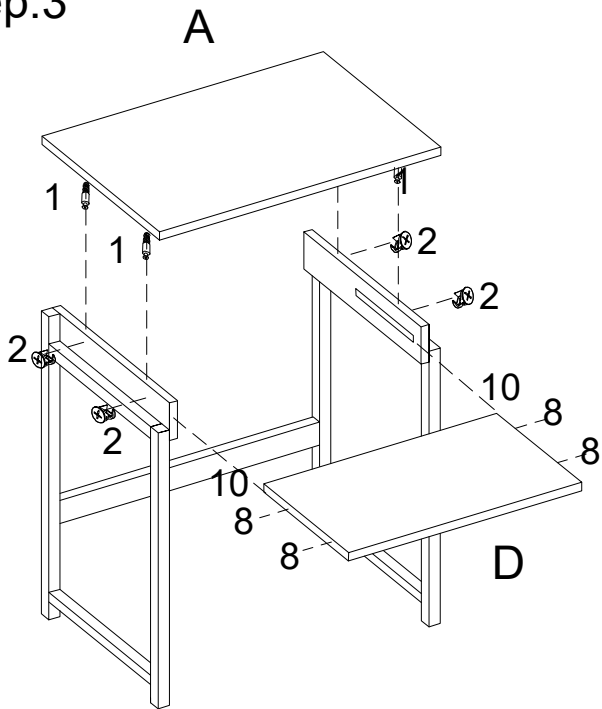

Install the drawer board D, insert the track on the drawer into the track on the cabinet, then install the panel A.

### Step:4

5 ×8pcs	6 (M6*45) ×4pcs	7 ×4pcs
------------	--------------------	------------

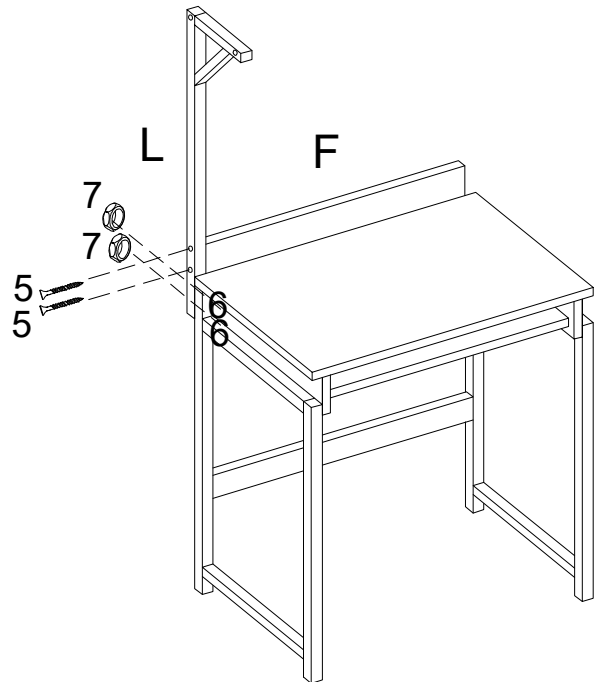

Connect square tube L and panel F .

### Step:5

3 (M6\*35)  
x4pcs

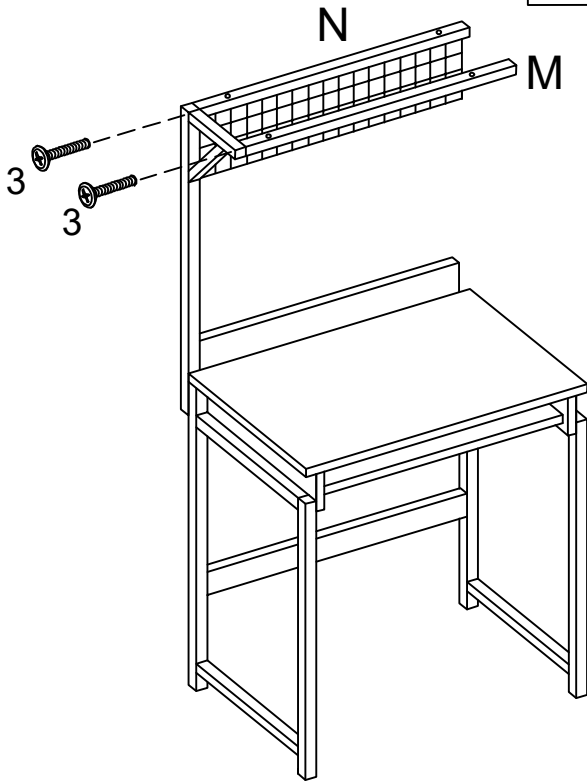

Connect the square tube M and N with fitting 3.

3 (M6\*35) x4pcs

5 x8pcs

6 (M6\*45) x4pcs

7 x4pcs

### Step:6

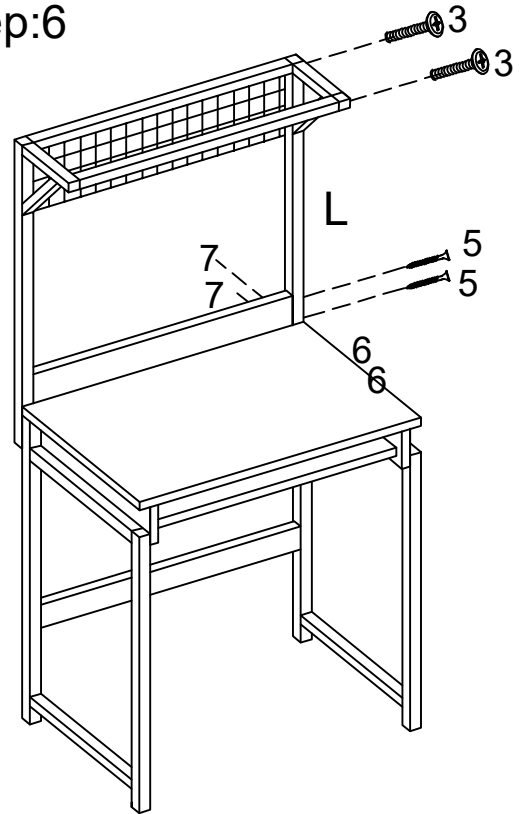

Connect the square tube L.

### Step:7

4 (M6\*30)  
x12pcs

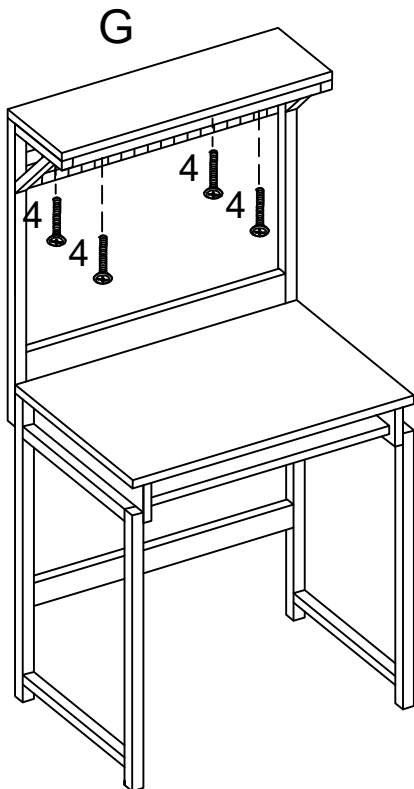

Connect panel G .

### Step:8

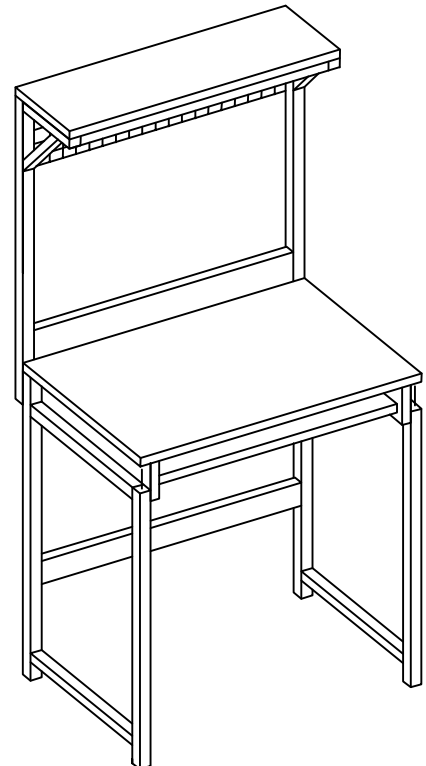

Installation completed

Step:1

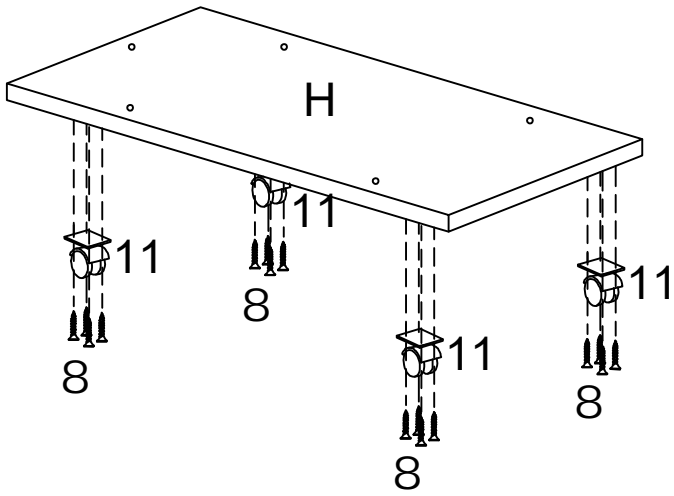

Step:2

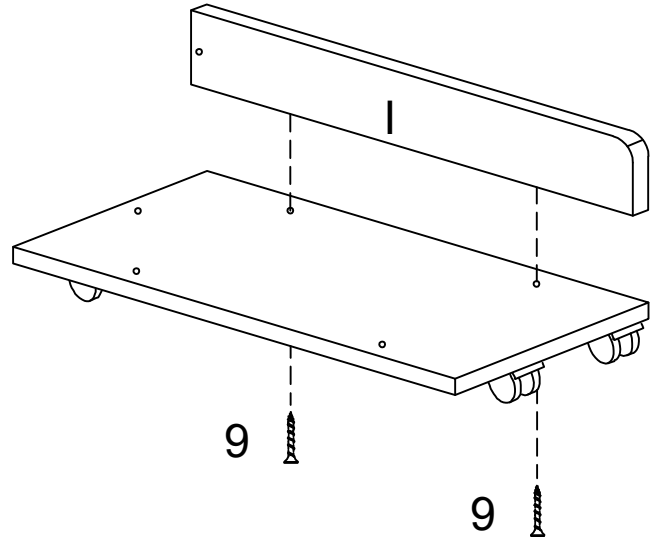

Step:3

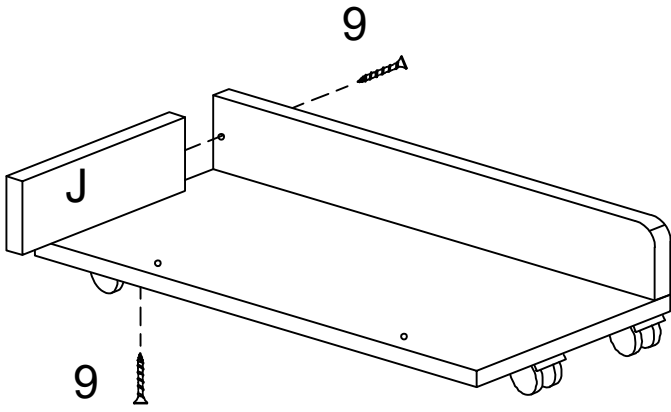

Step:4

