

Nr	X mm	Y mm	Z mm	Szt.	Nr	X mm	Y mm	Z mm	Szt.	Nr	X mm	Y mm	Z mm	Szt.
1	2160	600	16	1	9	259	1497	2,5	1	17	232	740	16	2
2	1468	600	16	1	10	1793	510	16	1	18	455	698	2,5	2
3	2160	600	16	1	11	1816	797	2,5	2	19	239	600	16	3
4	1468	80	16	2	12	1468	600	16	1	20	726	500	16	2
5	1968	600	16	1	13	726	500	16	2					
6	1780	798	16	1	14	150	450	16	2					
6A	1780	798	16	1	15	150	450	16	2	23	2160	200	16	1
					16	150	668	16	2	24	2160	200	16	1
										25	1532	200	32	1

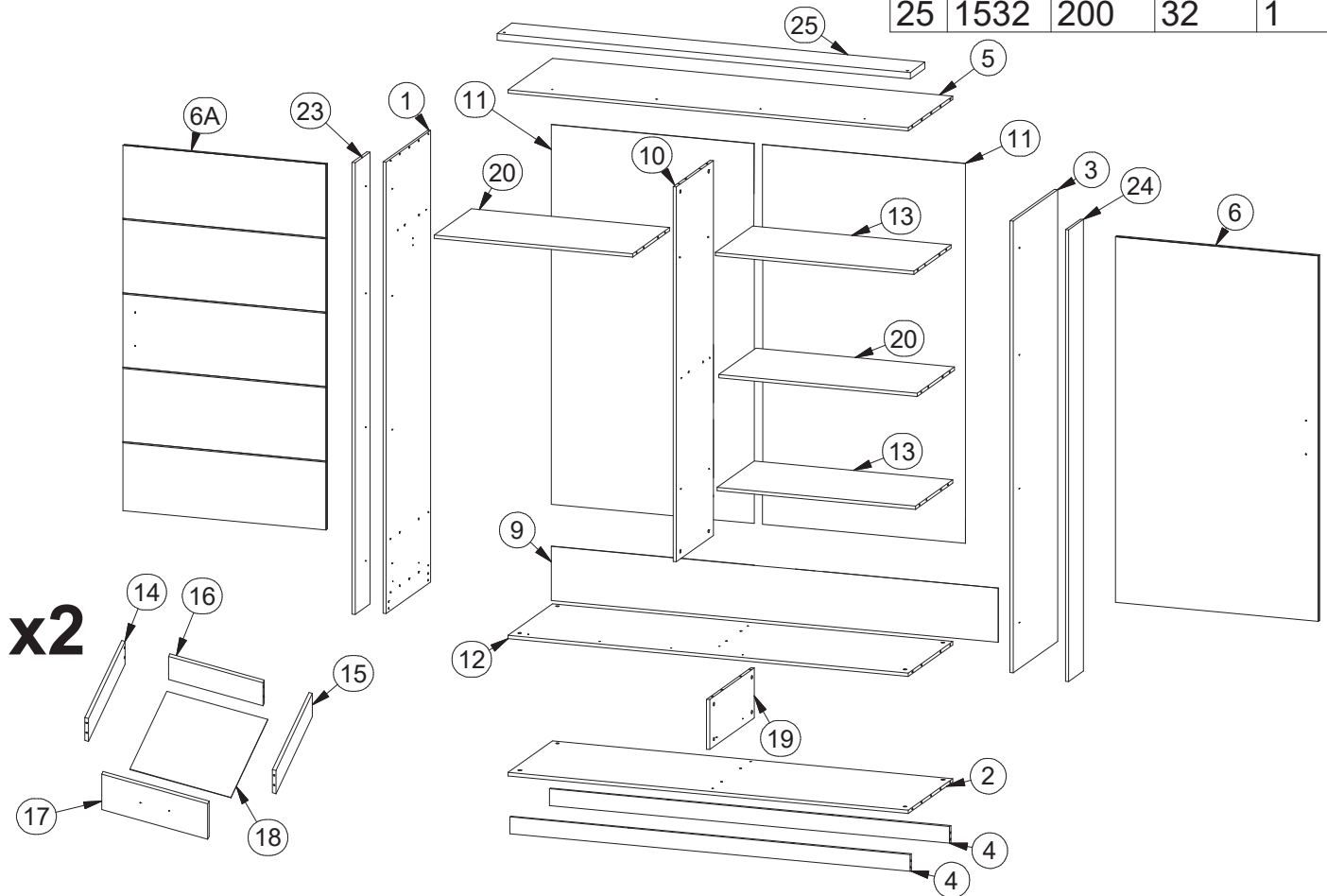

E1 2 x 160mm 	J 8 x 	C6 12 x Ø4x30 	C7 12 x 	C8 1 x 	H2 41 x
A 64 x Ø8x35 	B 32 x Ø15x12 	B1 32 x 34mm 	B2 32 x Ø17 	C 8 x Ø3,5x13 	C1 8 x Ø3x20
C2 8 x Ø3x25 	C3 22 x Ø3x16 	C4 112 x Ø4x16 	B3 4x 	D1 2 x 450mm 	D2 2 x 450mm
D3 2 x 450mm 	D4 2 x 450mm 	E 2 x 128mm 	F 1 x 718mm 	F1 2 x 	G 4 x
G1 4 x 	H 8 x 	I 1 x 1467mm 	I1 1 x 1467mm 	K 1 x 	Z 1 x

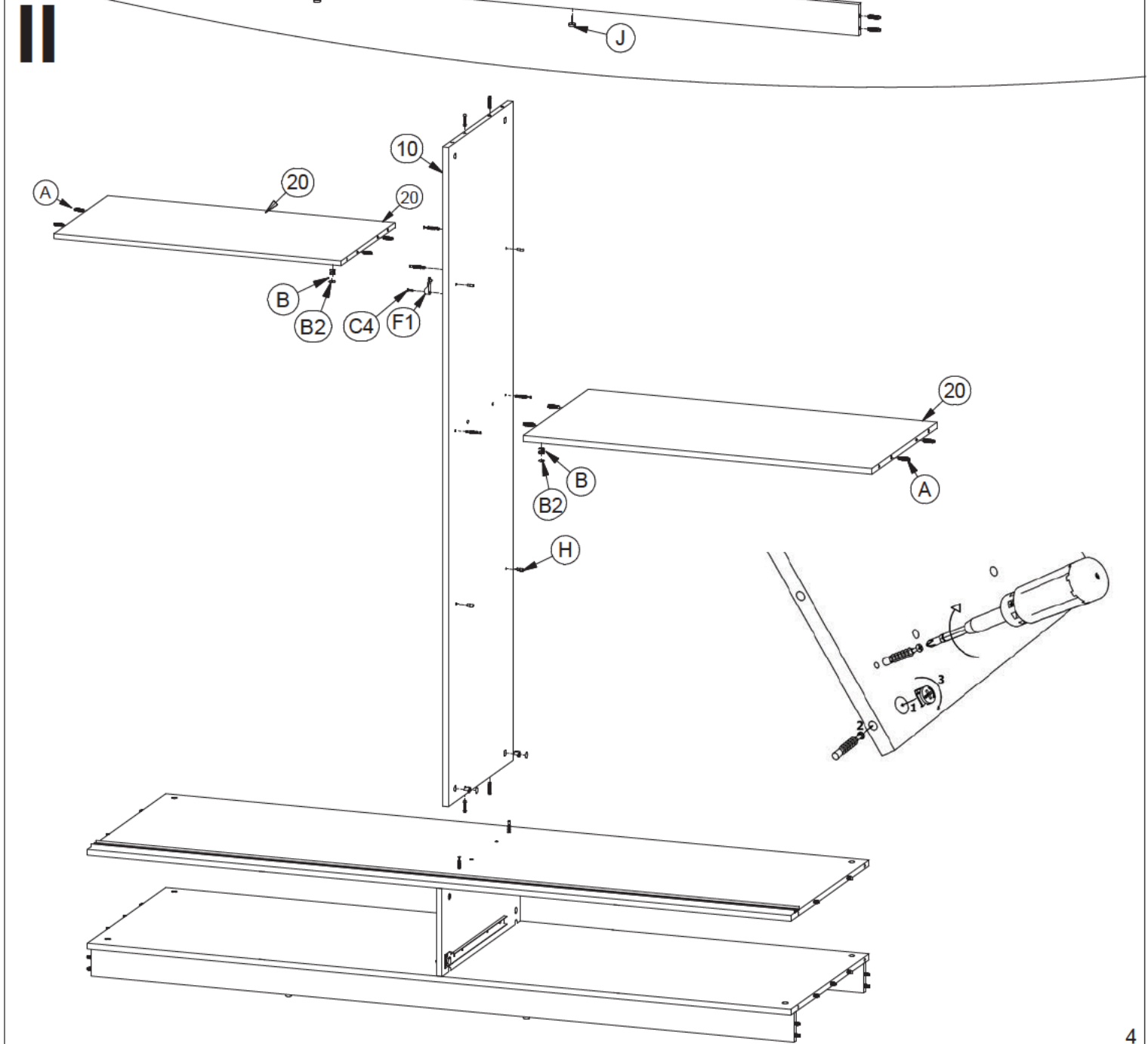

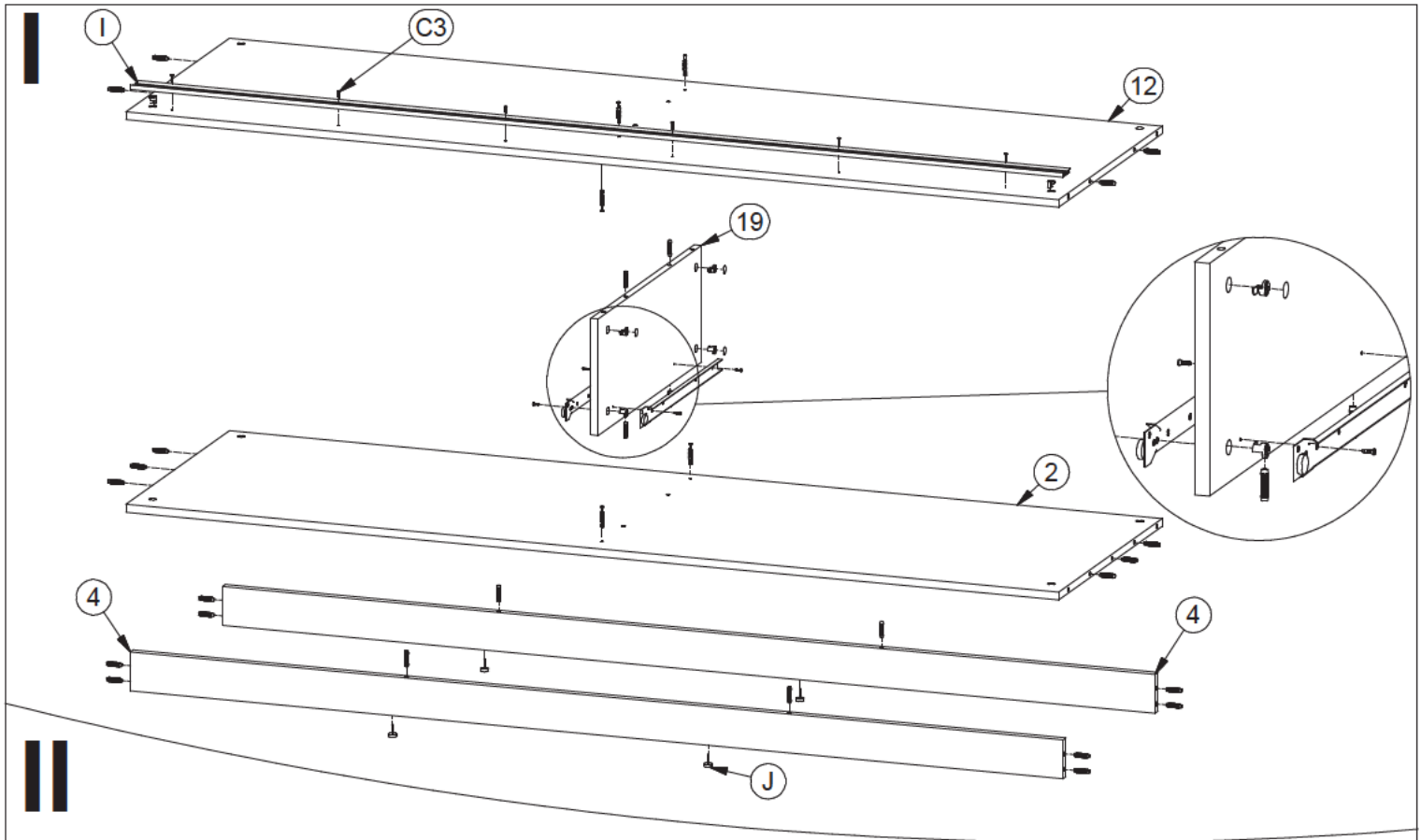
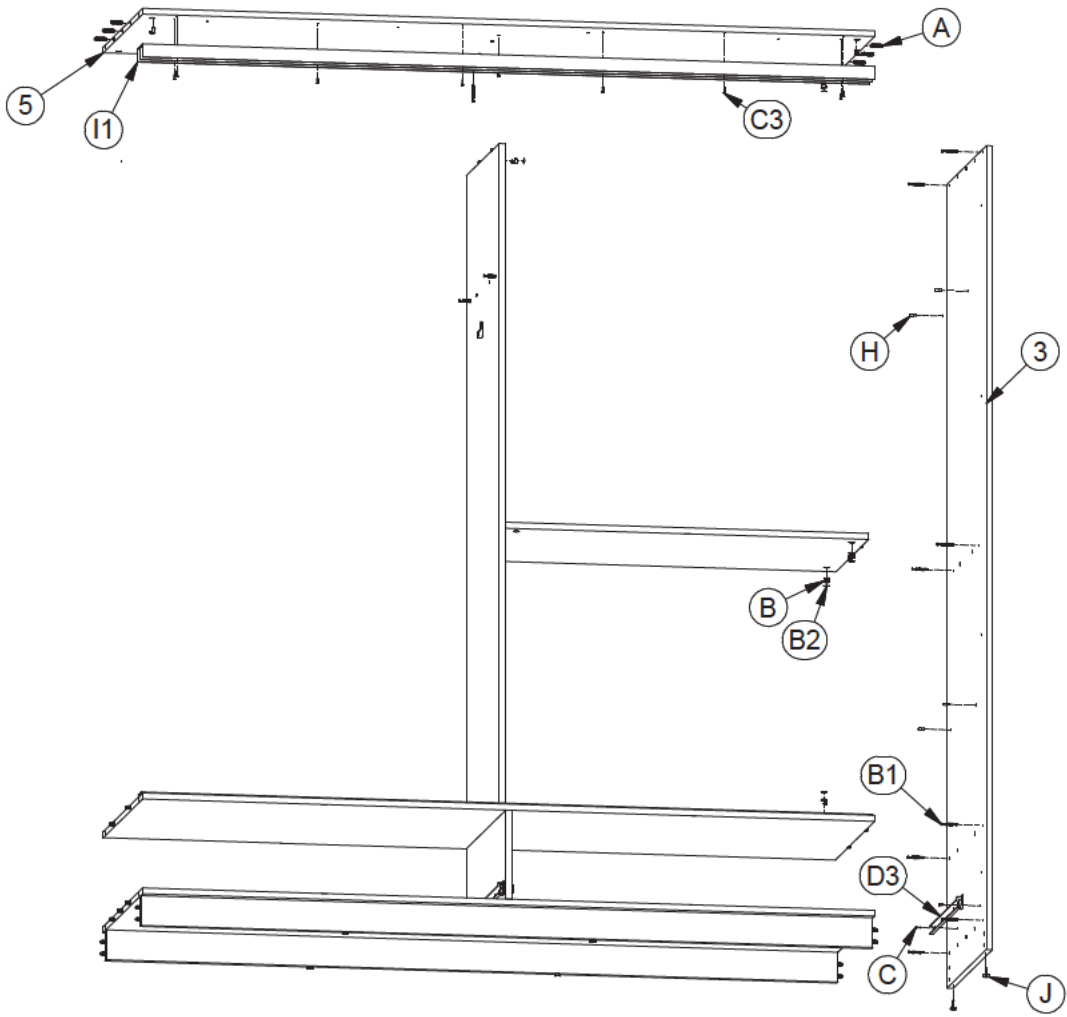

IV

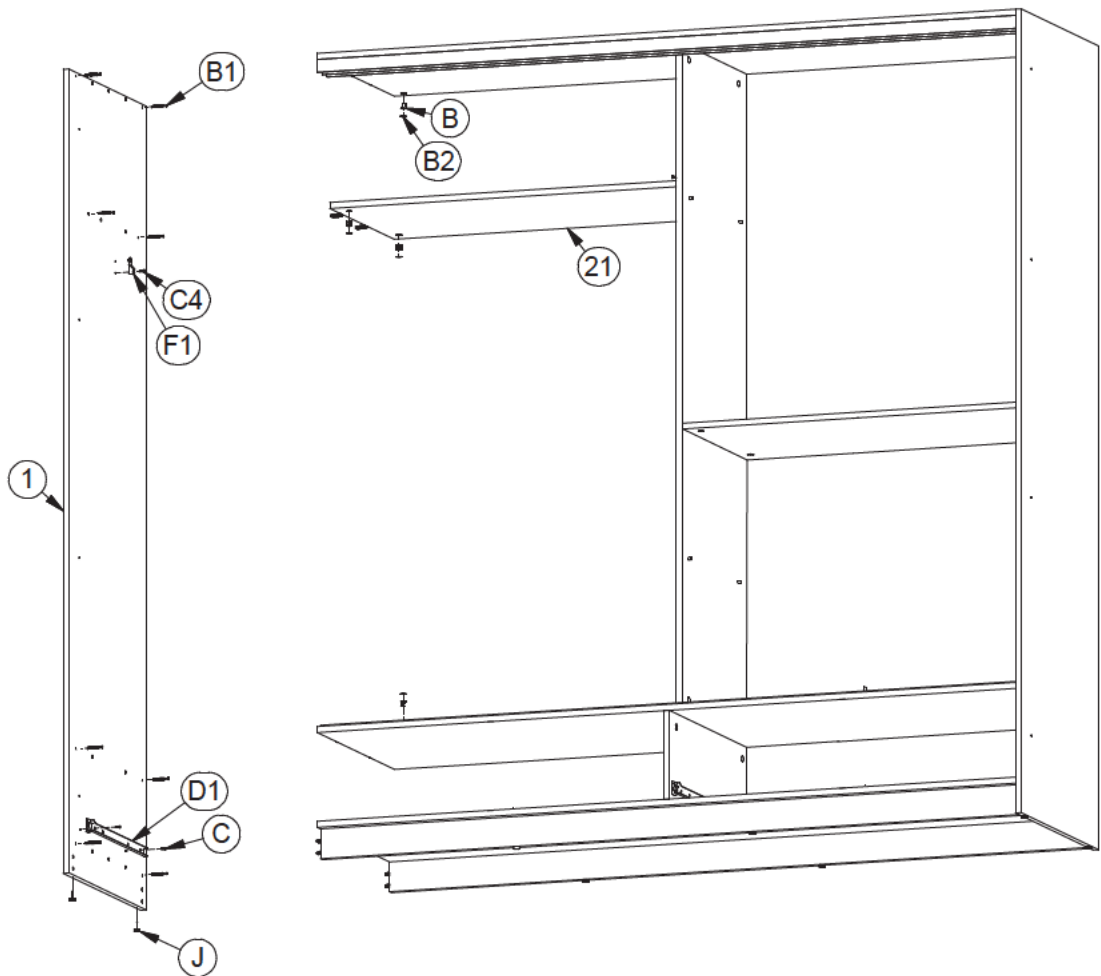

V

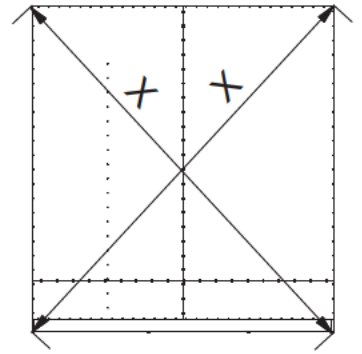
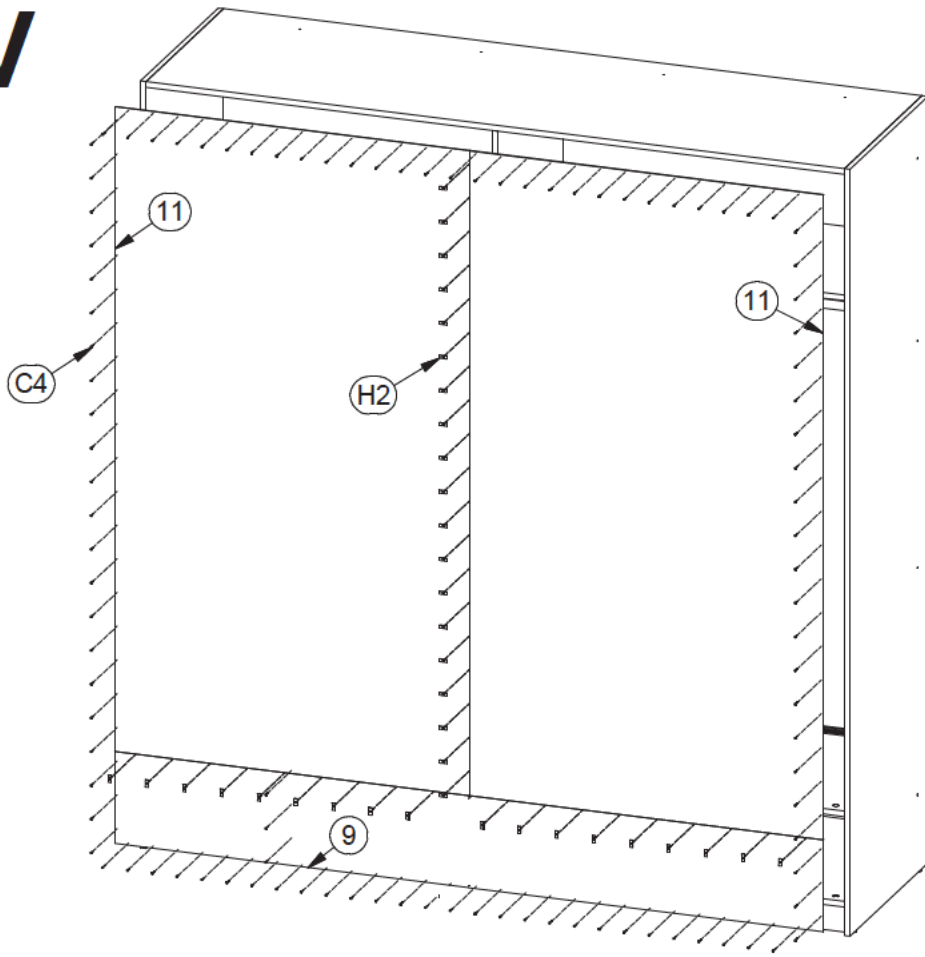

VI

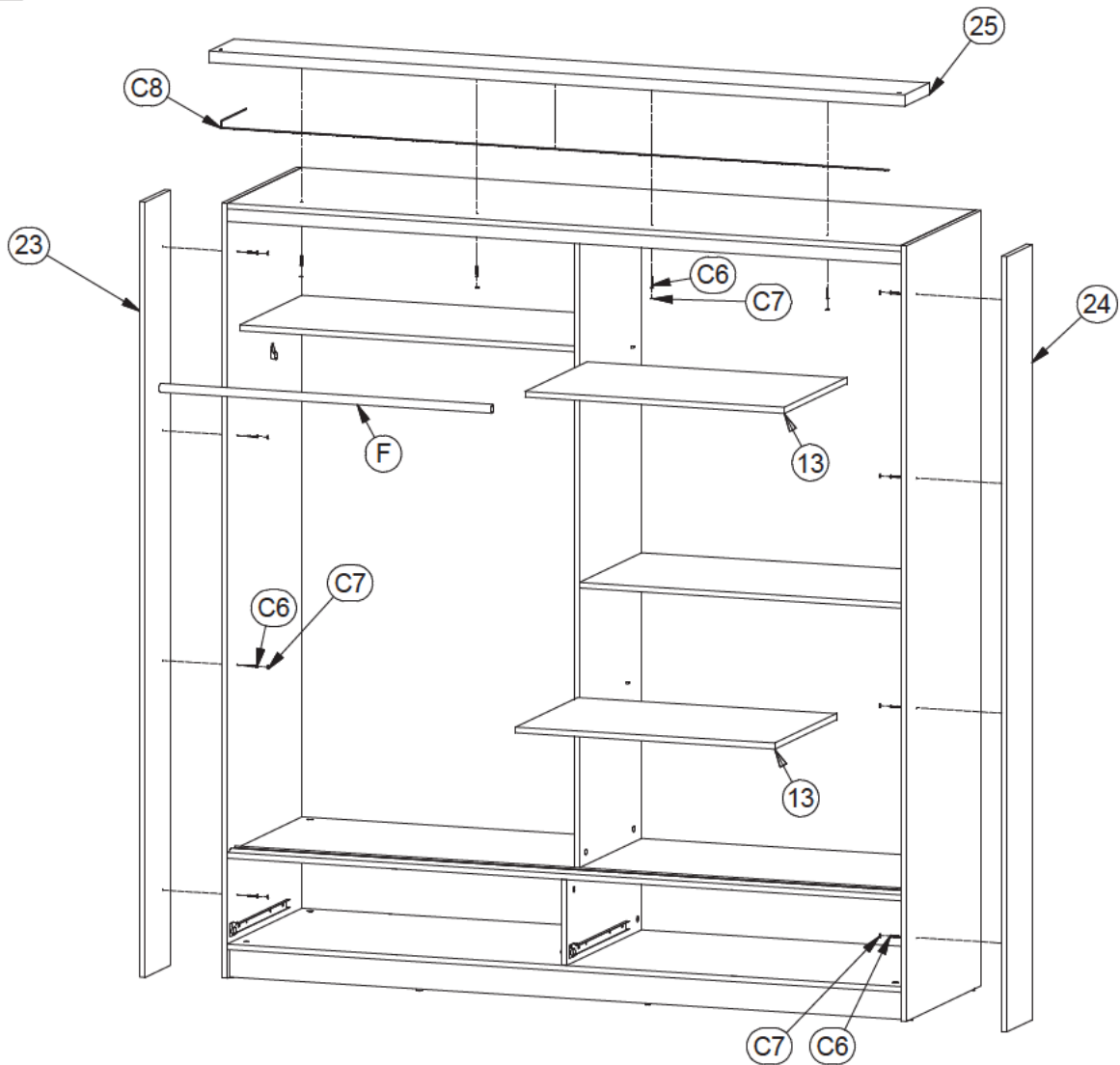

VII

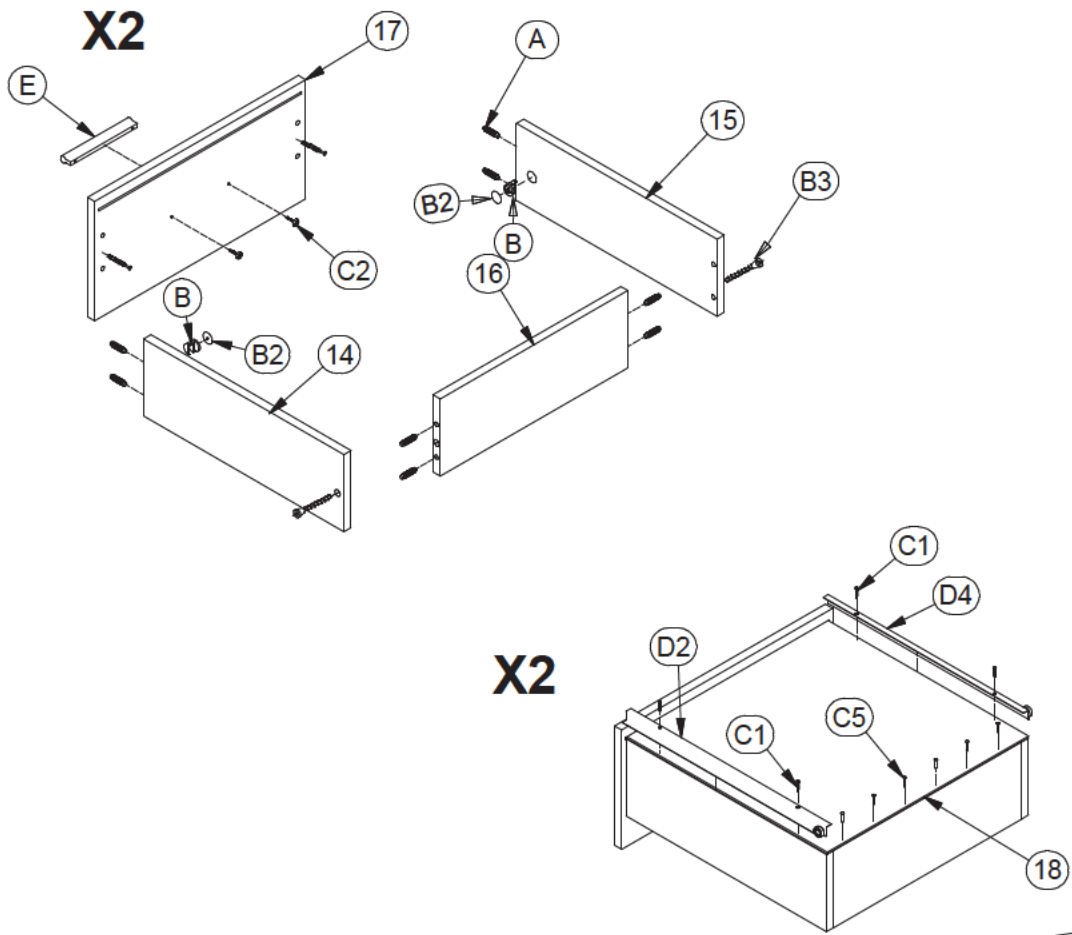

VIII

