

ASSEMBLY INSTRUCTIONS

DINING CHAIR

ASSEMBLY
REQUIREMENTS

1-Person
Assembly

30 Minutes
Assembly Time Per Chair
(Approximate)

Tool Required
(Not Provided)

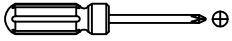
Phillips Screwdriver

Thank you for purchasing our product!

Please refer and use this assembly instruction to assemble the product.
Contact our customer service department in case there are any missing or damaged parts or hardware. Replacement parts are normally shipped within 2 or 3 days.

**PRODUCTS PURCHASED THROUGH OUR
AUTHORIZED VENDORS ONLY ARE
ELIGIBLE FOR REPLACEMENT PARTS**

We appreciate your business!

**THIS PRODUCT IS FOR INDOOR AND HOUSEHOLD USE ONLY
- NOT FOR COMMERCIAL USE.**

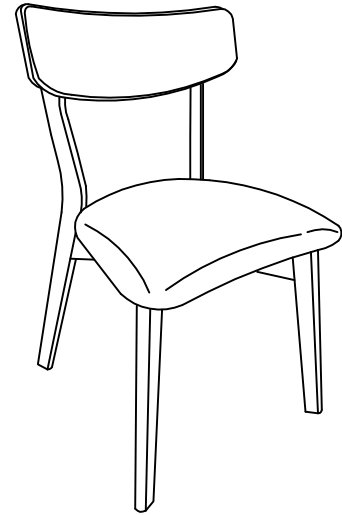

ASSEMBLY PREPARATION

1. Remove all packaging materials, staples and packing straps from the carton.
2. Refer to Part List and Hardware List and ensure they are complete before you start assembling. Contact customer service for missing part.
3. Place all wooden parts on a clean, flat and soft surface (e.g. carpet or rug) to prevent parts from getting scratched.

SAFETY PRECAUTION

1. KEEP ALL HARDWARE PARTS OUT OF REACH OF CHILDREN.
2. DISPOSE PLASTIC PACKAGING MATERIAL IMMEDIATELY TO AVOID ANY RISK OF SUFFOCATION TO CHILDREN AND ANIMALS.

TIPS FOR ASSEMBLY

1. Allow ample room for assembly and in close proximity to where product will be placed.
2. Assemble the product on a surface that does not scratch or damage the exterior gloss and finish of the furniture.
3. Please check all of the parts and quantities are included before assembly. Contact customer service for missing parts.
4. Identify all of the parts, hardware and quantities required for each step.
5. During assembly, do not over-tighten any fittings as this may cause damage.
6. DO NOT USE POWER TOOLS TO ASSEMBLE THIS PRODUCT.
7. Always place the product on a flat surface.
8. Do not sit or stand on the partially assembled product; only use the product for which it is intended.

CARE AND MAINTENANCE

- Wipe clean with a soft, dry cloth; avoid the use of harsh chemicals or household cleaners as they may damage the exterior finish of the furniture.
- Hardware may loosen over time. Periodically, check that all connections are tight; re-tighten as necessary.
- Solid wood is impacted by heat and humidity fluctuations which may cause small joint separations or hairline cracks; place the furniture away from direct sunlight and air conditioning vents, heating vents or units to protect the furniture.

ASSEMBLY INSTRUCTIONS

DINING CHAIR

PARTS LIST (FOR 2 CHAIRS)

NO.	COMPONENT	QTY.
A	LEG FRAME - LEFT	2 PCS.
B	LEG FRAME - RIGHT	2 PCS.
C	HEAD REST	2 PCS.
D	CUSHION SEAT	2 PCS.
E	FRONT SUPPORT PANEL	2 PCS.
F	SIDE SUPPORT PANEL	4 PCS.

HARDWARE LIST (FOR 2 CHAIRS)

NO.	DESCRIPTION	QTY.	EXTRA
H1	JCBC BOLT M6 x 35 MM	8 PCS.	1 PC.
H2	JCBC BOLT M6 x 75 MM	8 PCS.	1 PC.
H3	1/4" SPRING WASHER	16 PCS.	1 PC.
H4	JCBC/W M7 x 50MM	2 PCS.	1 PC.
H5	CB SCREW M4 x 25MM	24 PCS.	1 PC.
H6	ALLEN KEY M4 x 110MM	1 PC.	-
H7	WOOD BUTTON D14.5mm	8 PCS.	1 PC.

*EXTRA HARDWARE FOR SPARE USE

STEP 1

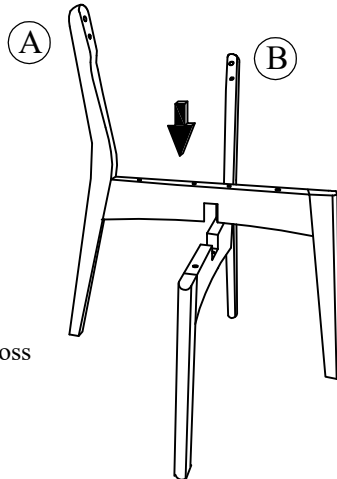

- a) Fit Leg Frame Left (A) across Leg Frame Right (B) to complete the half-lap joint.

STEP 2

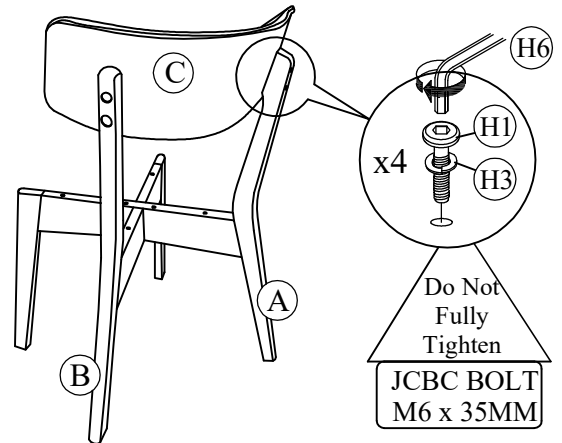

- a) Attach Head Rest (C) to the Leg Frame Left (A) & Right (B).
 b) Use JCBC Bolt (H1) fitted with Spring Washer (H3) to fasten (C) to (A & B). Use Allen Key (H6) to drive (H1). Do not tighten (H1) completely at this time.

STEP 3

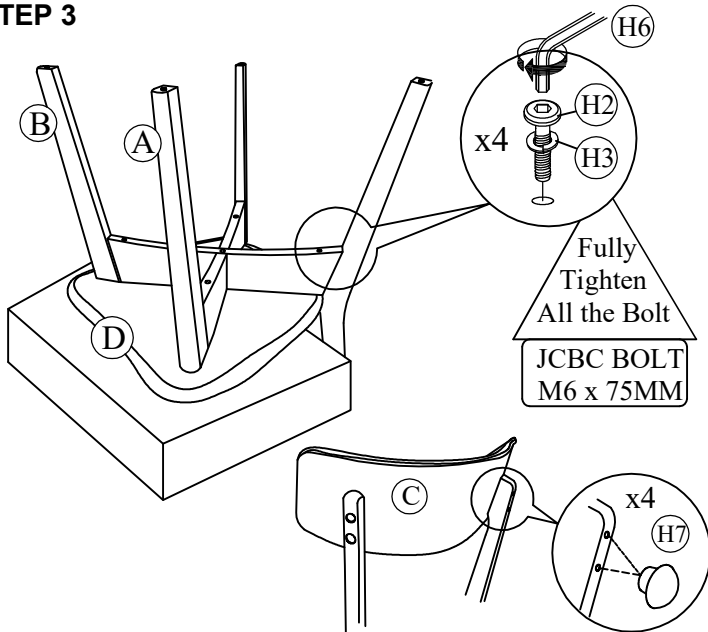

- a) Place Cushion Seat (D) bottom-side up on an elevated surface (e.g. table top)
 b) Place leg assembly from STEP 2 as shown on (D) and align the bolt holes on both parts.
 c) Use JCBC Bolt (H2) fitted with Spring Washer (H3) to fasten (D) to (A & B). Use Allen Key (H6) to drive (H2). Do not tighten (H2) completely until all 4 bolts are in place.
 d) **TIGHTEN JCBC BOLT (H1) IN STEP 2 COMPLETELY AT THIS TIME. DO NOT OVER-TIGHTEN.**
 e) Use Wood Button (H7) to conceal the screw holes on each Leg Frame.

STEP 4

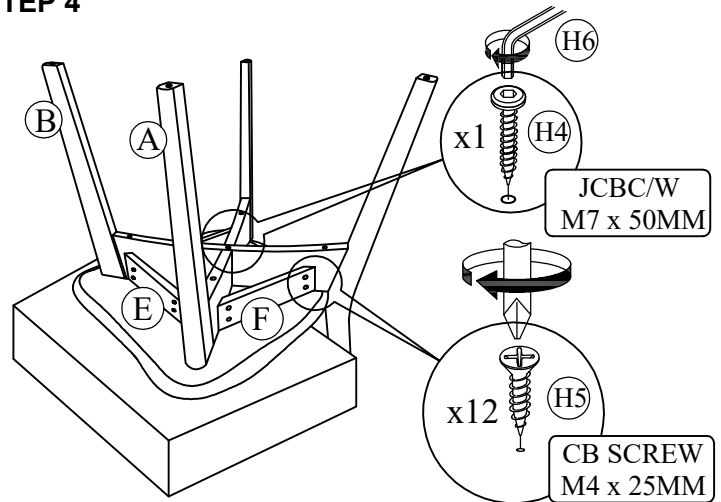

- a) Attach Front Support Panel (E) and Side Support Panel (F) to the Leg Frame Left (A) & Leg Frame Right (B).
 b) Use Screw (H5) to fasten (E) and (F) to Leg Frame (A & B). Use a Phillips screwdriver to drive and tighten (H5). Do not tighten each screw completely until all the screws are in place.
 c) At the center hole of the half-lap joint use JCBC Screw (H4) to secure the joint. Use a Allen Key (H6) to drive and tighten (H4).
 Set the chair right-side up. The assembly of the chair is complete.