

ASSEMBLY INSTRUCTIONS

Executive Desk with Hutch

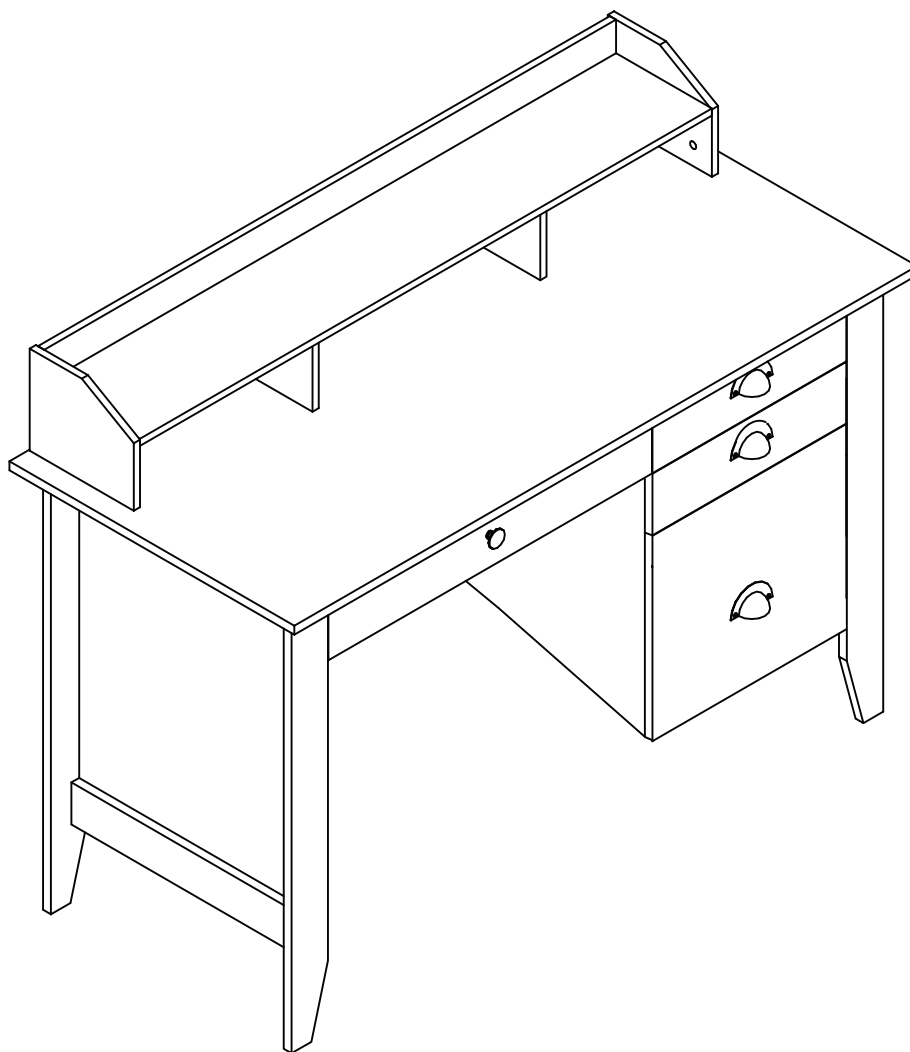

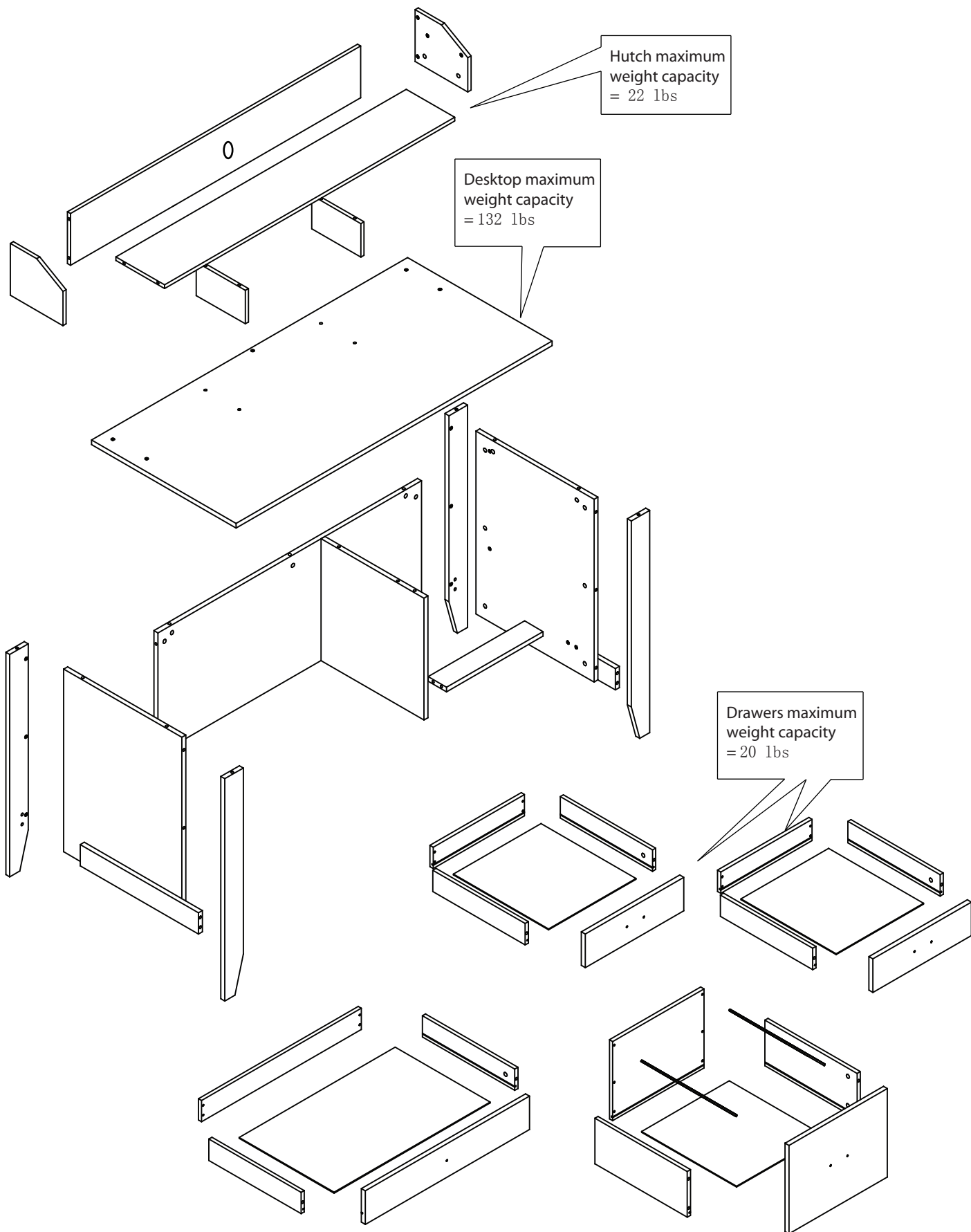





ASSEMBLY OVERVIEW

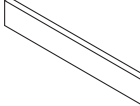

PARTS LIST 1 OF 3

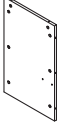
THE PART NUMBER CAN BE FOUND ON THE SIDE OF THE PART, EITHER STAMPED OR ON A STICKER.
ITEMS ARE NOT SHOWN TO SCALE.

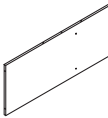
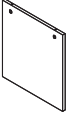
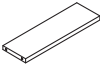

#	DESCRIPTION		QTY.
1	Left Corner Board, Front		1
2	Left Board		1
3	Left Corner Board, Back		1
4	Trim Board		2
5	Right Corner Board, Front		1
<u>6</u>	Right Board		1
7	Right Corner Board, Back		1
8	Back Board		1
<u>9</u>	Center Board		1
10	Support Board		1

PARTS LIST 2 OF 3

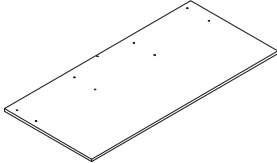
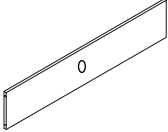
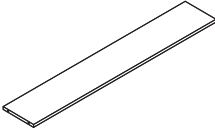
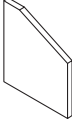
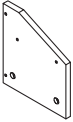
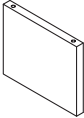
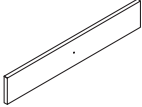
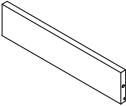
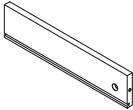
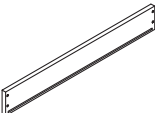
THE PART NUMBER CAN BE FOUND ON THE SIDE OF THE PART, EITHER STAMPED OR ON A STICKER.
ITEMS ARE NOT SHOWN TO SCALE.



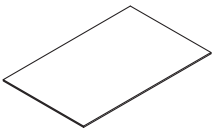
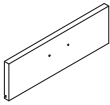
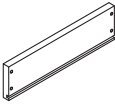
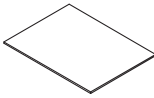
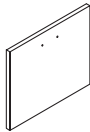
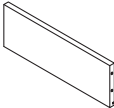
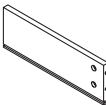
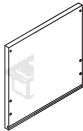
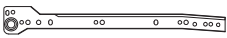

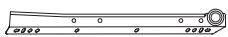
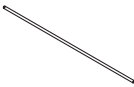







#	DESCRIPTION		QTY.
11	Desktop		1
12	Hutch Back		1
13	Hutch Shelf		1
14	Hutch Left Board		1
15	Hutch Right Board		1
16	Hutch Middle Board		2
17	Medium Drawer, Front Board		1
18	Drawer Left Board		3
19	Drawer Right Board		3
20	Medium Drawer, Back Board		1

THE PART NUMBER CAN BE FOUND ON THE SIDE OF THE PART, EITHER STAMPED OR ON A STICKER.
 ITEMS ARE NOT SHOWN TO SCALE.

#	DESCRIPTION		QTY.
21	Drawer Bottom A		1
22	Small Drawer, Front Board		2
23	Small Drawer, Back Board		2
24	Drawer Bottom B		3
25	Large Drawer, Front Board		1
26	Large Drawer, Left Board		1
27	Large Drawer, Right Board		1
28	Drawer Left Board		1
30	Outer Drawer Rollers	Left  Right 	4 sets of 4
31	Inner Drawer Rollers	Left  Right 	
32	File Holder		2

HARDWARE LIST

EXTRA HARDWARE INCLUDED FOR YOUR CONVENIENCE. ITEMS ARE NOT SHOWN TO SCALE.

PART	DESCRIPTION		QTY.
A	Bolt		56
B1	Large Cam		32
B2	Small Cam		24
C	Dowel		20
D	M4 x 14MM		32
E	M5 x 40MM		16
F1	M4 x 22MM		6
F2	M4 x 18MM		1
G	Nut		6
H	Small Handle		1
I	Large Handle		3
J	Plastic Grommet		1
K	Sticker		24

⚠ CAUTION

- READ THE INSTRUCTION MANUAL BEFORE ASSEMBLING.
- REMOVE ALL PIECES BEFORE BEGINNING INSTALLATION.
- OPEN THE HARDWARE AS NEEDED .
- ASSEMBLE IN AN AREA WITH PLENTY OF SPACE.
- READ EACH STEP BEFORE BEGINNING CONSTRUCTION.
- NEVER FORCE THE SCREWS OR FITTINGS.
- KEEP THIS MANUAL FOR FUTURE REFERENCE.
- TIGHTEN ALL THE SCREWS EVERY 6 MONTHS.
- HAVE A SCREWDRIVER BEFORE YOU BEGIN ASSEMBLING (NOT INCLUDED).
- DO NOT USE A POWER DRILL.

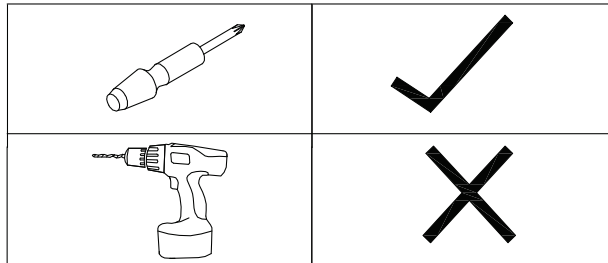

CLEANING AND CARE

- CLEAN SURFACES WITH A DRY OR DAMP CLOTH.
- DO NOT USE ABRASIVE CLEANERS.

IF YOU ARE MISSING ANY OF THESE PARTS, OR IF YOU HAVE A DAMAGED PART, PLEASE VISIT WWW.COMFORTPRODUCTS.NET/SUPPORT REFERENCE THE MODEL # ON THE FRONT OF THIS MANUAL. SIMPLY COMPLETE THE INFORMATION, INCLUDING THE PART YOU NEED. THE PART WILL NORMALLY BE SHIPPED WITHIN 48 HOURS.

ASSEMBLY INSTRUCTIONS

STEP 1

Insert twenty Dowels (C) into the boards shown below.

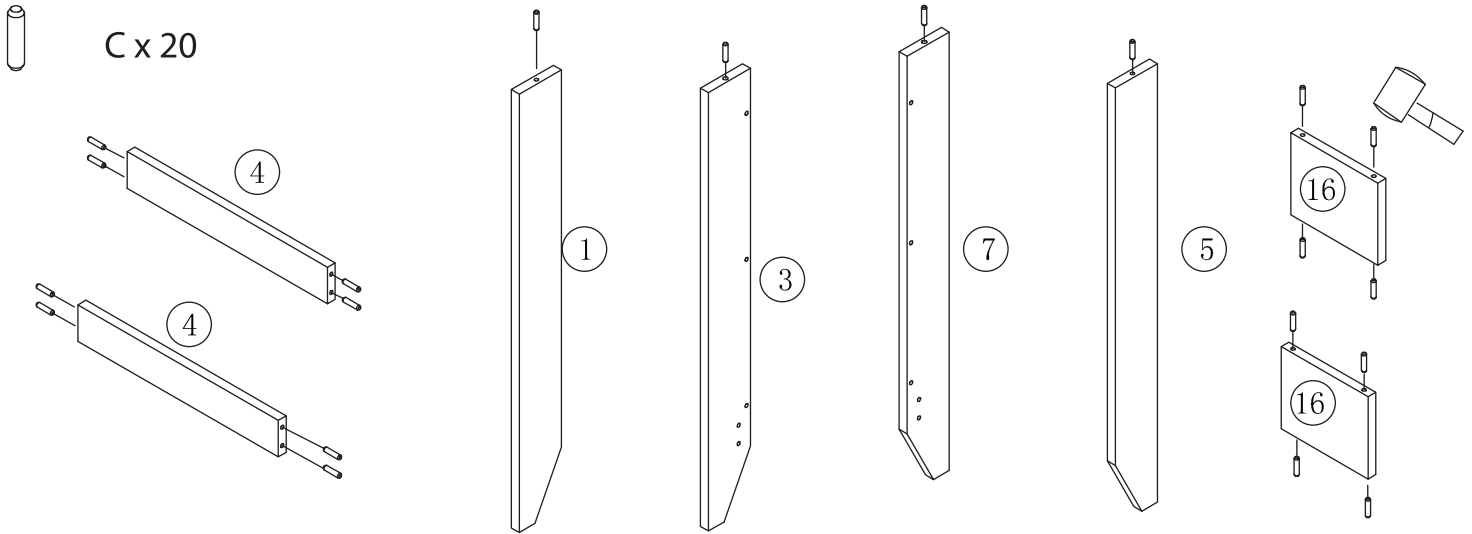

STEP 2

Attach a Left Outer Roller (30) to the Left Board (2) with two Screws (D).

Attach two Right Outer Rollers (30) to the Right Board (6) with four Screws (D).

Attach two Left Outer Rollers (30) to one side of the Center Board (9) and one Right Outer Roller (30) to the other side with six Screws (D).

Refer to the drawings for which holes in the rollers to use.

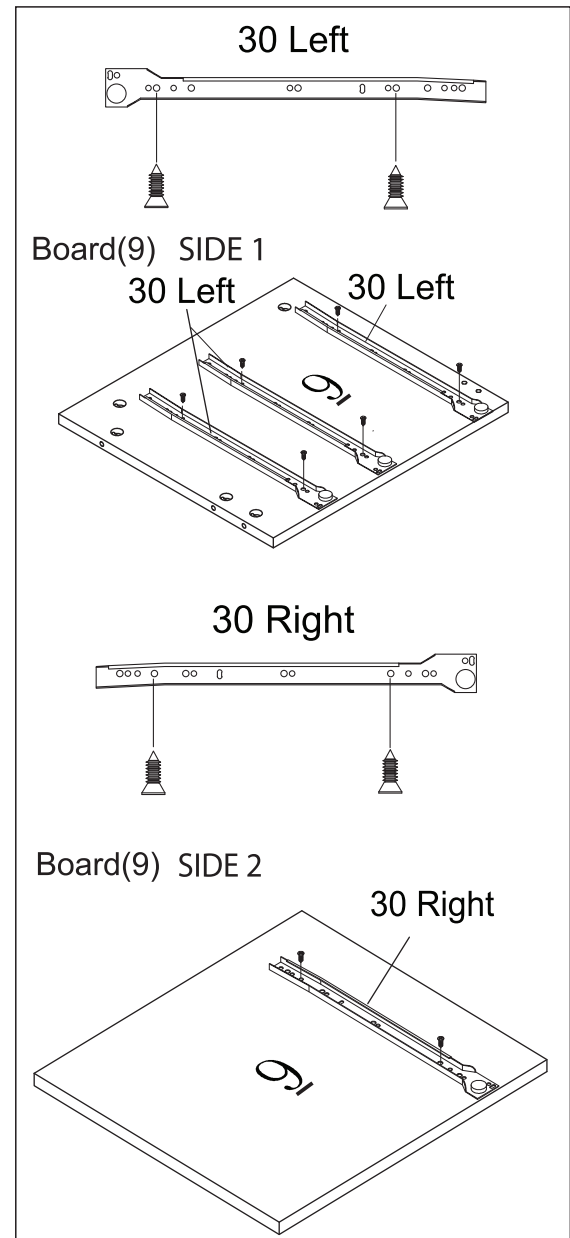
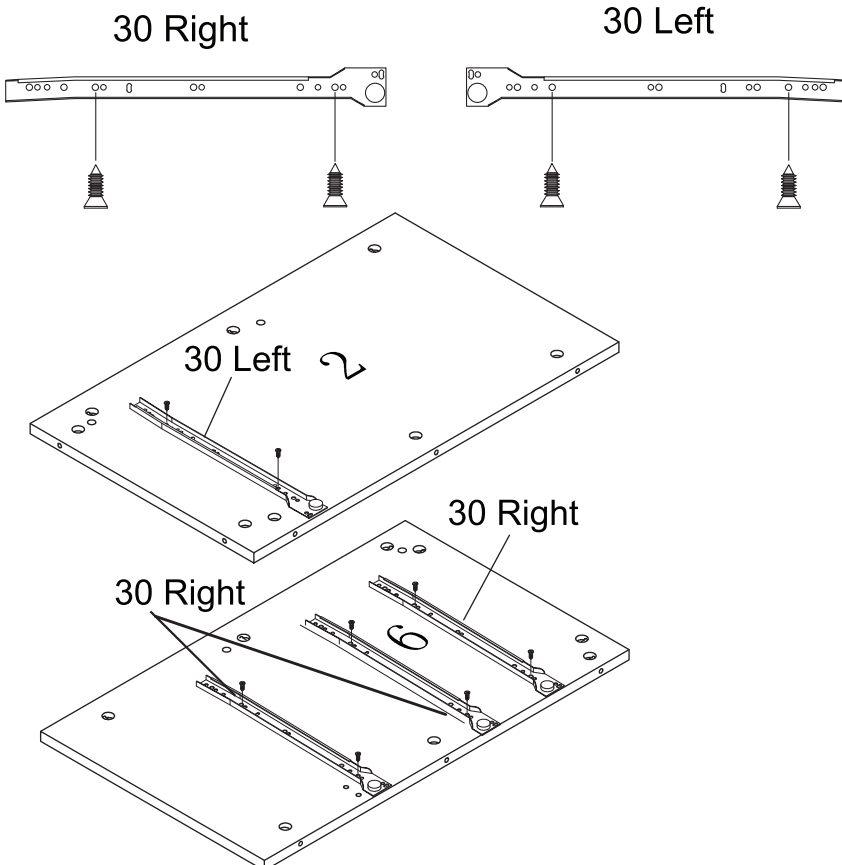

ASSEMBLY INSTRUCTIONS

STEP 3

Fix eighteen Bolts (A) to the Boards shown below.

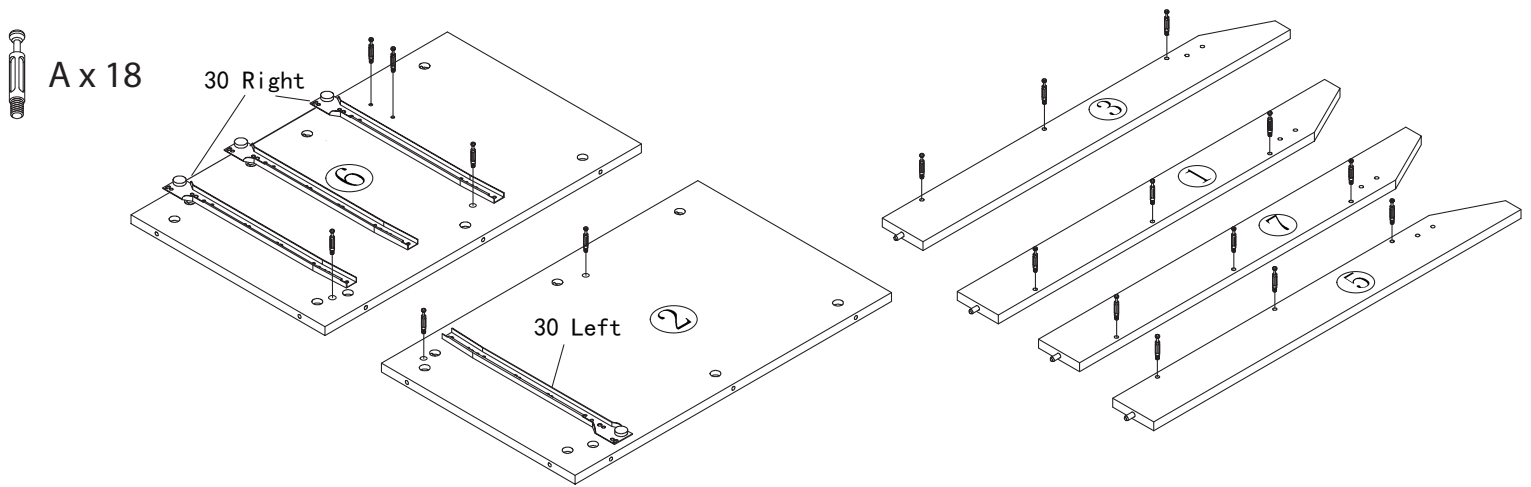

STEP 4

Insert twelve Large Cams (B1) into the Left (2) and Right (6) Boards. Make sure the arrows are pointing toward the holes where the bolts go in.

Attach the Left Corner Boards, Front (1) and Back (3) to the Left Board (2) and one Trim Board (4) by inserting the Bolts and turning the Cams clockwise half a turn to lock into place. At the same time, insert the dowels of the Trim Board (4) into the holes of the Front and Back Boards.

Attach the Right Corner Boards, Front (5) and Back (7) to the Right Board (6) and the other Trim Board (4) in the same way.

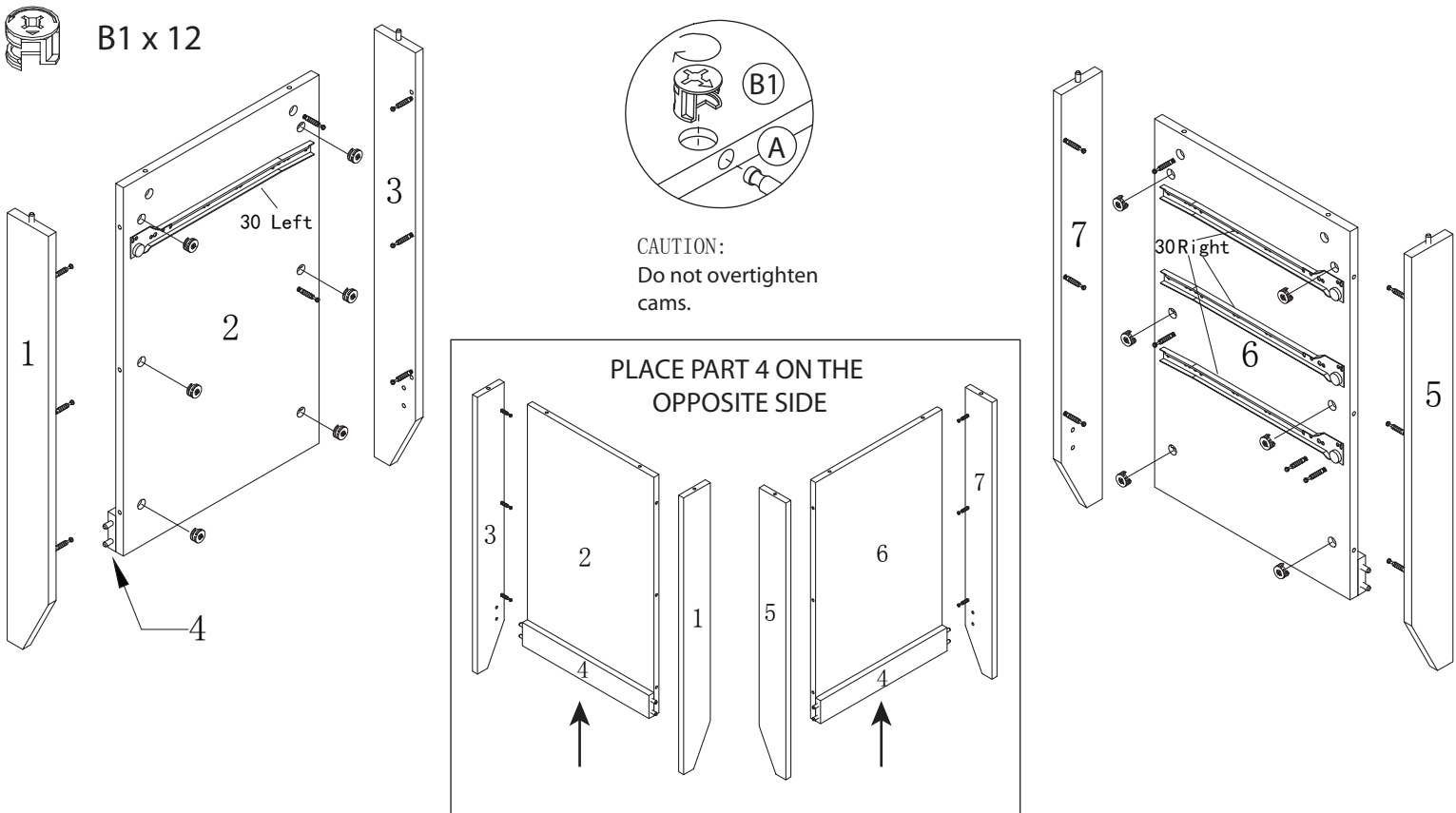

ASSEMBLY INSTRUCTIONS

STEP 5

Fix two Bolts (A) to the Back Board (8). Insert two Large Cams (B1) into the Center Board (9), making sure the arrows are pointing toward the holes for the Bolts. Attach the Center Board to the Back Board by inserting the Bolts and tightening the Cams clockwise half a turn.

Fix two Bolts (A) to the Center Board (9). Insert two Large Cams (B1) into the Support Board (10). Attach the Support Board to the Center Board.



A x 4

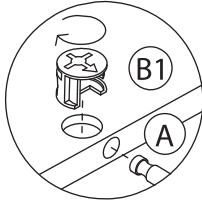

CAUTION:

Do not overtighten cams.



B1 x 4

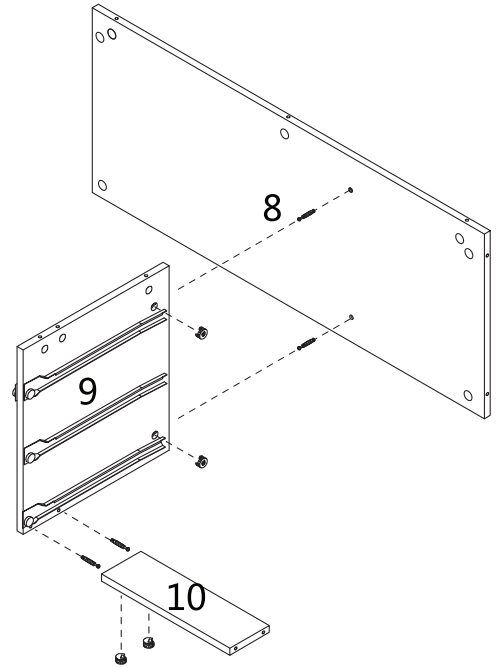

STEP 6

Insert four Large Cams (B1) into the Back Board (8) and two more Large Cams into the Support Board (10).

Attach the Left Board (2) to the Back Board (8) and attach the Right Board (6) to the Back Board (8) and the Support Board (10) by inserting the Bolts and tightening the Cams.

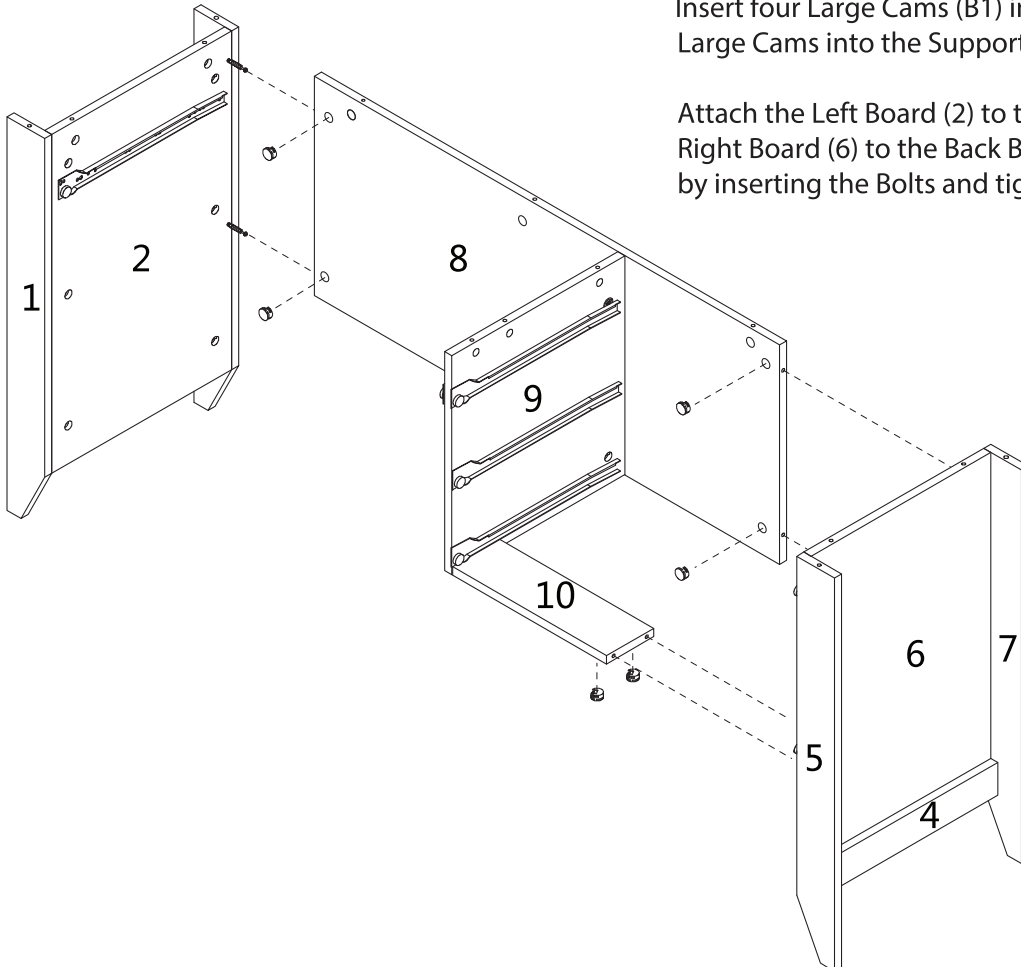

B1 x 6

ASSEMBLY INSTRUCTIONS

STEP 7

Fix ten Bolts (A) to the underside of the Desktop (11).



A x 10

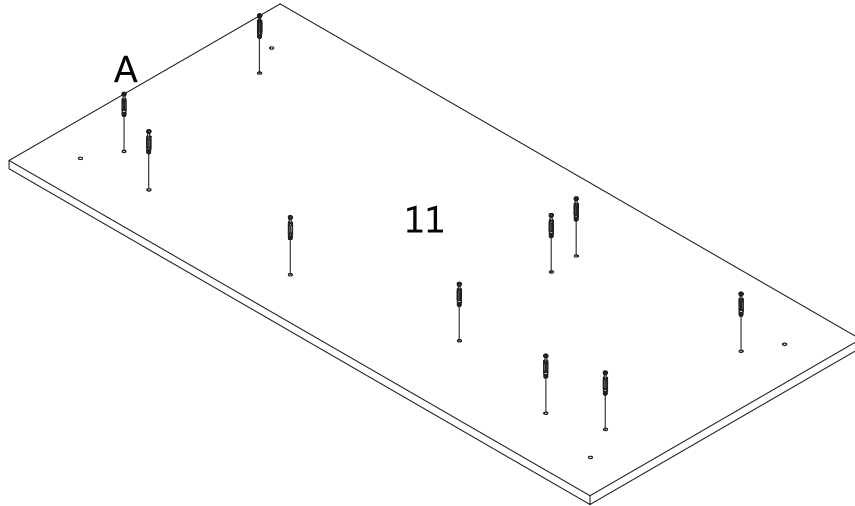

STEP 8

Insert ten Large Cams (B1) into the Left (2), Back (8), Center (9), and Right (6) Boards as shown. Align the Bolts in the Desktop (11) with the holes and the Dowels in the lower part of the desk. Lower the Desktop making sure all Bolts and Dowels are fully inserted and then tighten the Cams.



B1 x 10

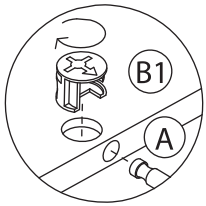

CAUTION:

Do not overtighten cams.

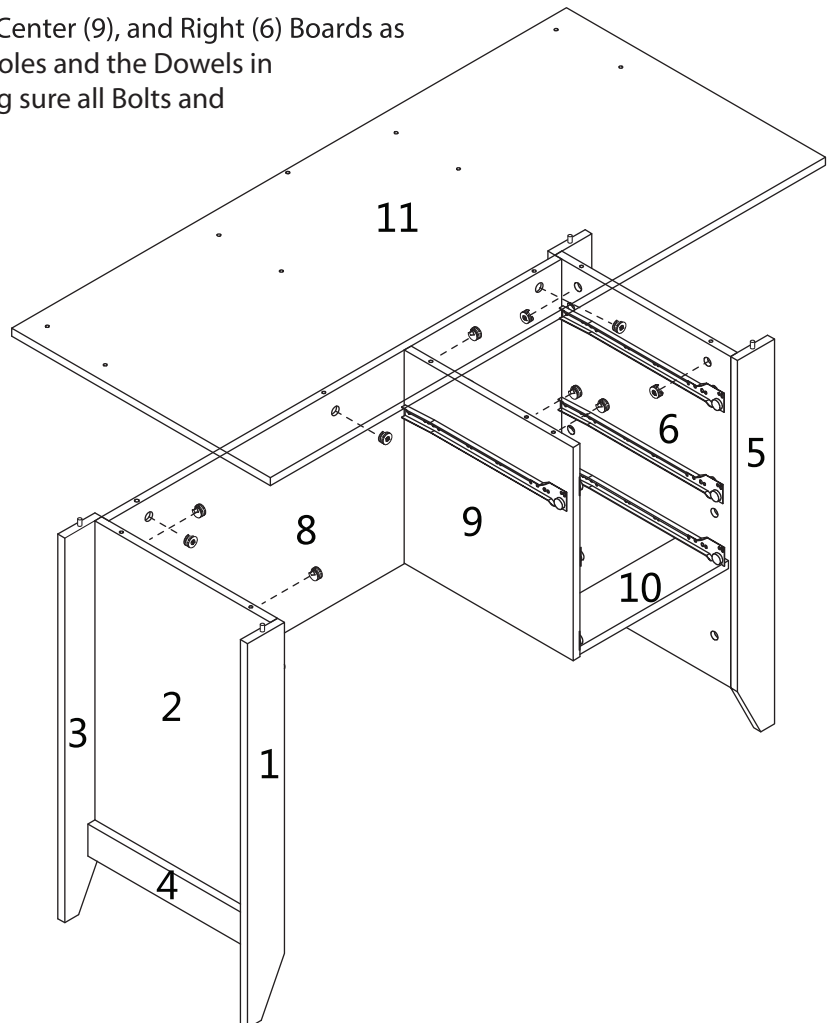

ASSEMBLY INSTRUCTIONS

STEP 9

Fix one Bolt (A) to the center of the Hutch Back (12). Insert the Grommet (J) into the round hole.

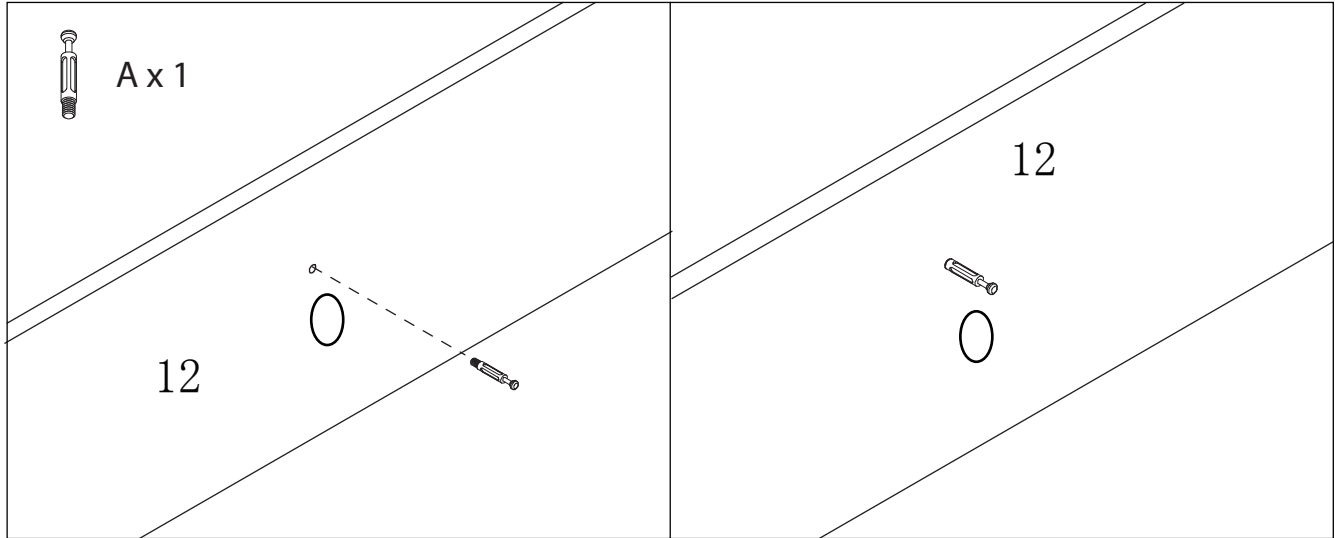

STEP 10

Insert a Small Cam (B2) into the Hutch Shelf (13). Attach the Hutch Back (12) to the Hutch Shelf by inserting the Bolt and tightening the Cam. Attach the two Hutch Center Boards (16) to the underside of the Shelf (13) by aligning the Dowels with the holes and pressing the boards together until tight.

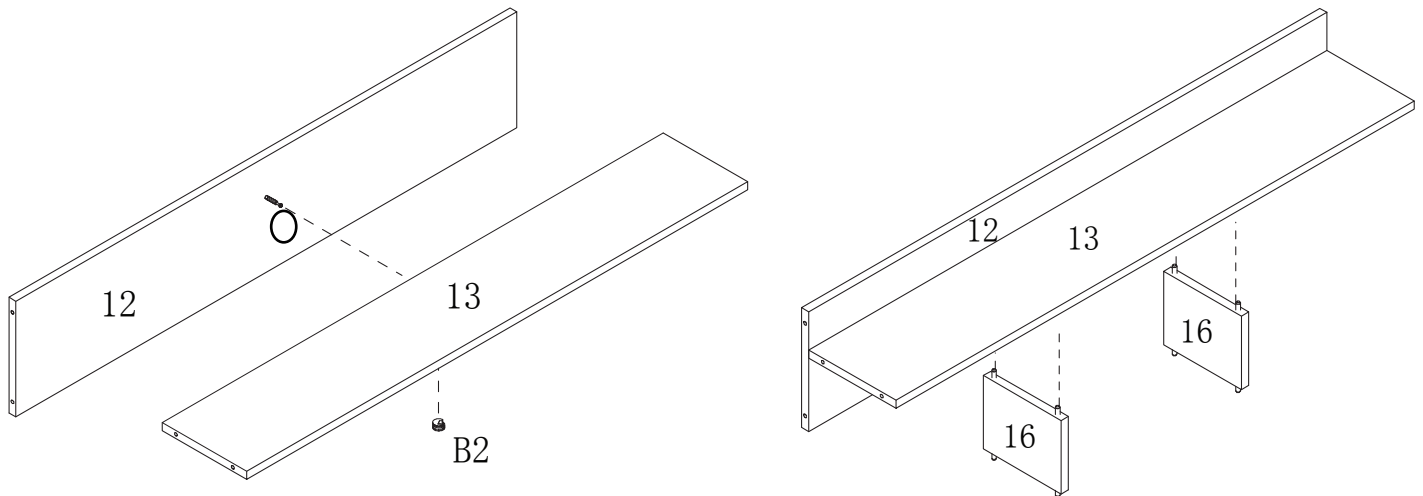

ASSEMBLY INSTRUCTIONS

STEP 11

Fix eight Bolts (A) to the Hutch Right (15) and Left (14) Boards. Insert eight Small Cams (B2) into the Hutch Back (12) and Hutch Shelf (13). Attach the Right and Left Boards to the Back and the Shelf by inserting the Bolts and tightening the Cams.

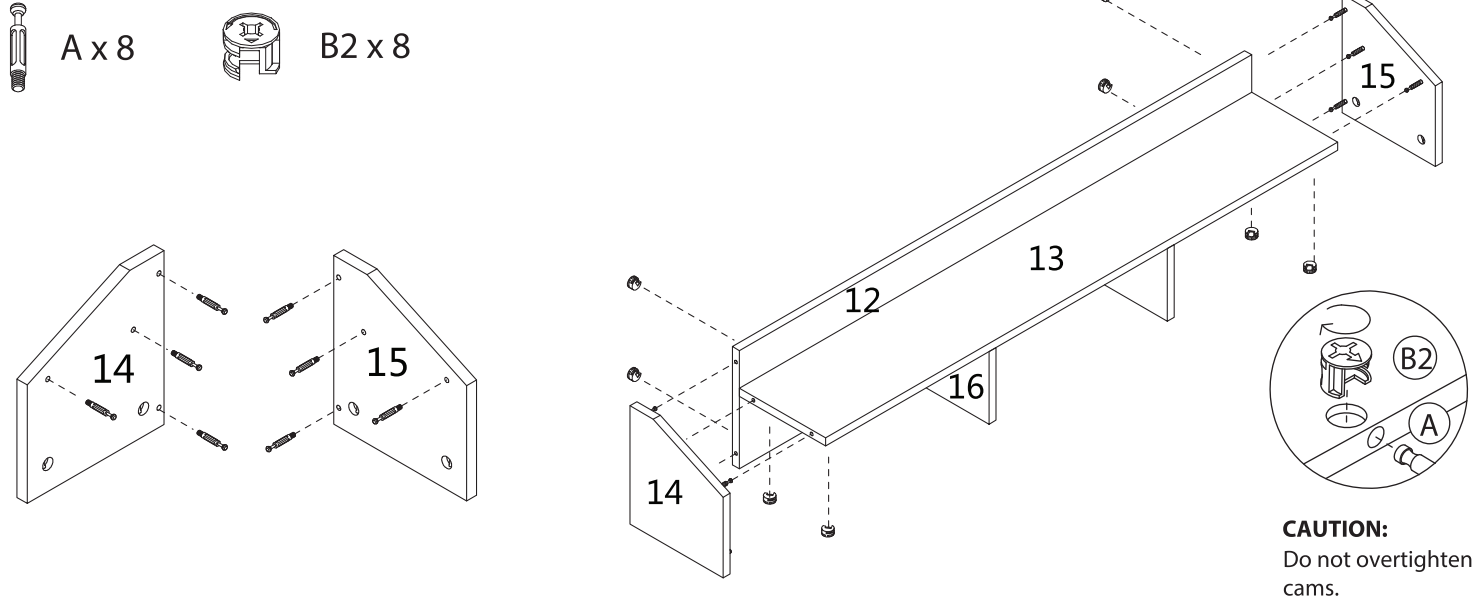

STEP 12

Fix five Bolts (A) to the Desktop (11). Insert five Small Cams (B2) into the Hutch Right Board (15), Hutch Left Board (14), and Hutch Back (12). Attach the Hutch to the Desktop by lowering it onto the Bolts and tightening the Cams. At the same time, make sure that the Dowels in the Hutch Center Boards (16) are aligned and tight in the other four holes on the Desktop.

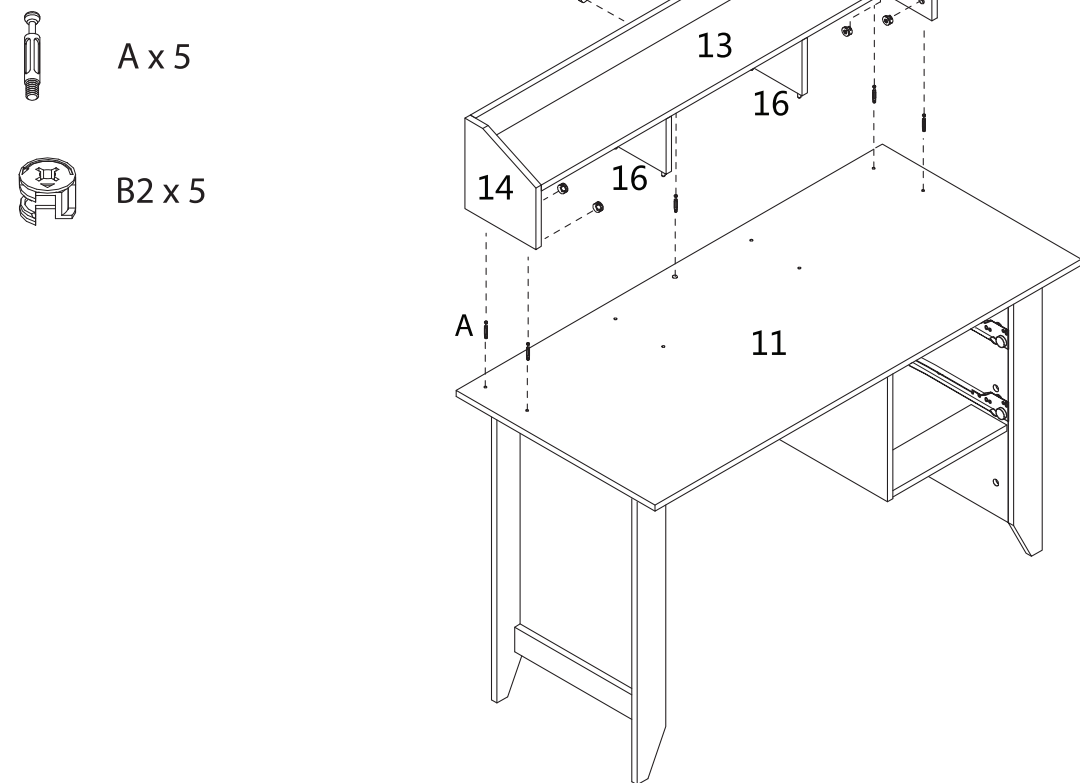

ASSEMBLY INSTRUCTIONS

STEP 13

Fix two Bolts (A) to the Medium Drawer Front (17), four Bolts to the Large Drawer Front (25), and two Bolts to the Small Drawer Front (22).



A x 10

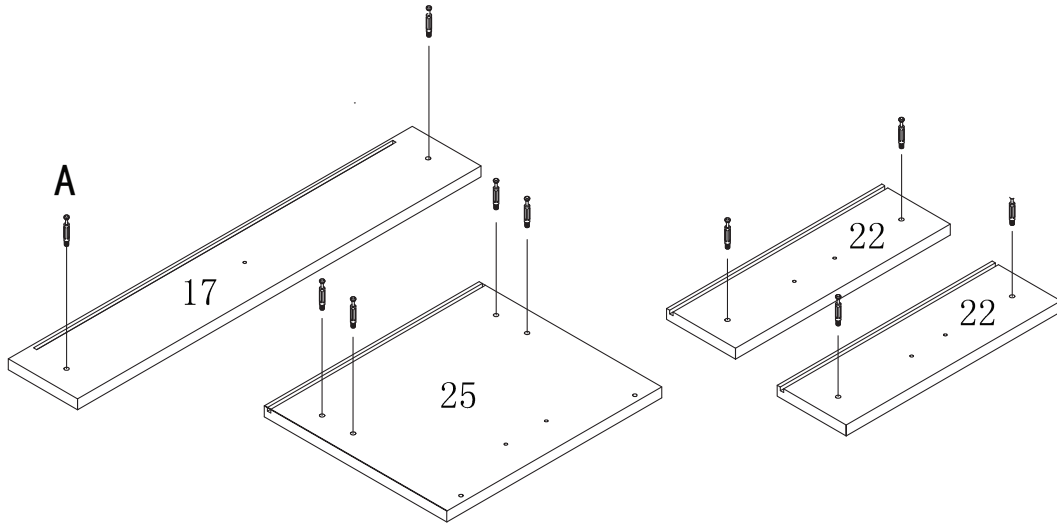

STEP 14

Insert one Small Cam (B2) into the Drawer Right Board (19) and one into the Drawer Left Board (18). Making sure the grooves are aligned, attach the Medium Drawer Front (17) to the Right and Left Boards by inserting the Bolts and tightening the Cams.

Slide Drawer Bottom A (21) into the grooves. Align the groove in the Medium Drawer Back (20) with the Drawer Bottom and fasten it to the Right (19) and Left (18) Drawer Boards using four Screws (E).

Attach the Small Handle (H) to the Drawer Front (17) using one Screw (F2).



B2 x 2



E x 4



H x 1



F2 x 1

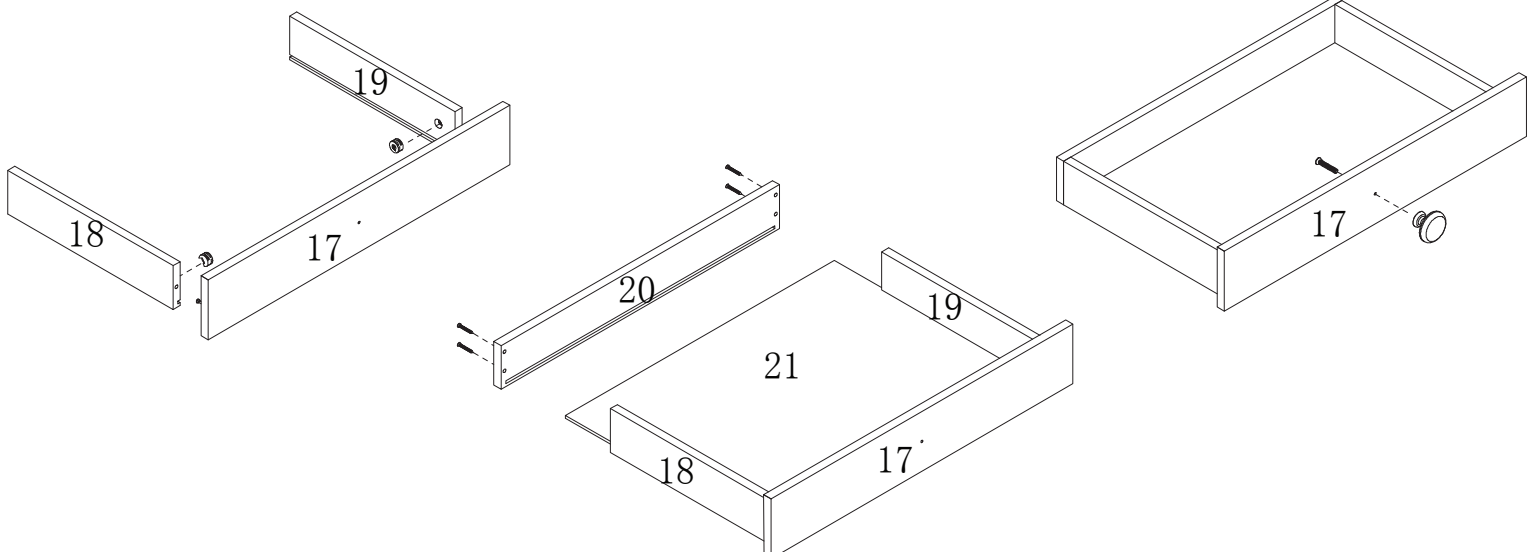

ASSEMBLY INSTRUCTIONS

STEP 15

Insert one Small Cam (B2) into the Drawer Right Board (19) and one into the Drawer Left Board (18). Making sure the grooves are aligned, attach the Small Drawer Front (22) to the Right and Left Boards by inserting the Bolts and tightening the Cams.

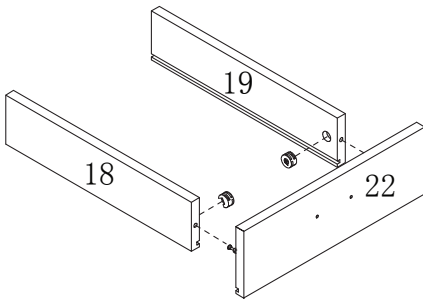
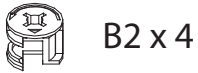

Slide Drawer Bottom B (24) into the grooves. Align the groove in the Small Drawer Back (23) with the Drawer Bottom and fasten it to the Right (19) and Left (18) Boards using four Screws (E).

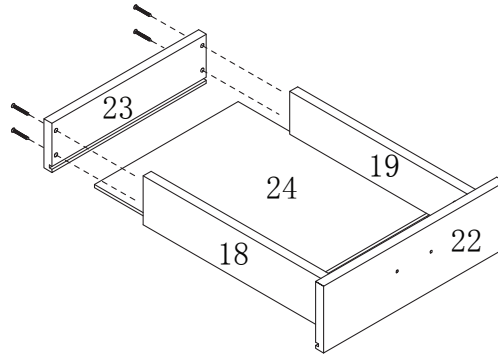

Attach a Large Handle (I) to the Drawer Front (22) using two Screws (F1) with two Nuts (G).

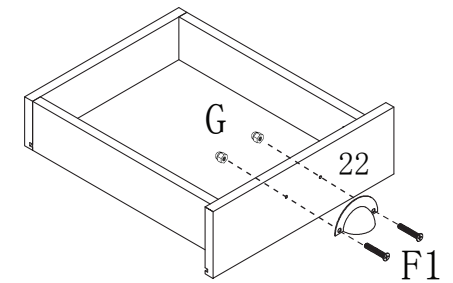
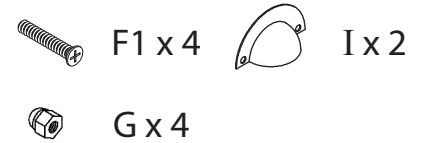

STEP 16

Insert two Small Cams (B2) into the Large Drawer Right (27) and two into the Large Drawer Left (26). Making sure the grooves are aligned, attach the Large Drawer Front (25) to the Right and Left Boards by inserting the Bolts and tightening the Cams.

Slide Drawer Bottom B (24) into the grooves. Align the groove in the Large Drawer Back (28) with the Drawer Bottom and fasten it to the Right (27) and Left (26) Boards using four Screws (E). At the same time, insert the File Holders (32) into the holes at the top of the Front and Back Boards.

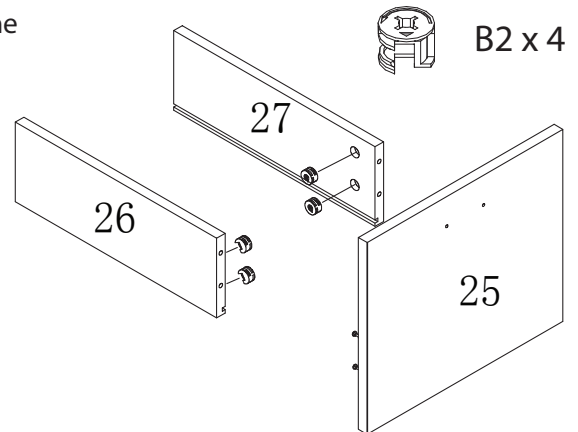
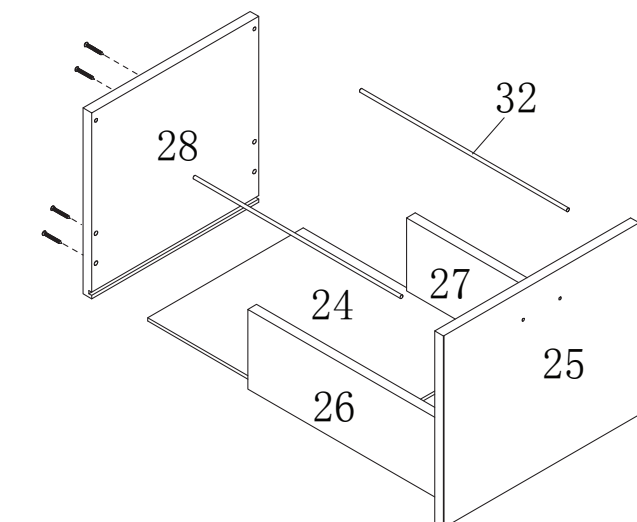

Attach a Large Handle (I) to the Drawer Front (22) using two Screws (F1) with two Nuts (G).

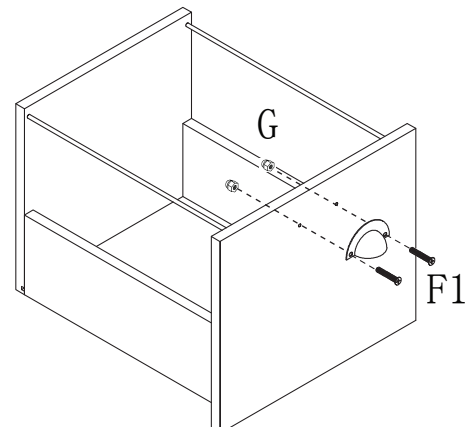
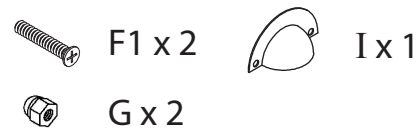

ASSEMBLY INSTRUCTIONS

STEP 17

Flip over the assembled drawer and attach a Right Inner Roller (31) and Left Inner Roller (31) with four Screws (D). The wheels should be at the back of the drawer. Use the outer holes for the screws as shown in the drawing.

Repeat this step for the other two drawers.

 DX16

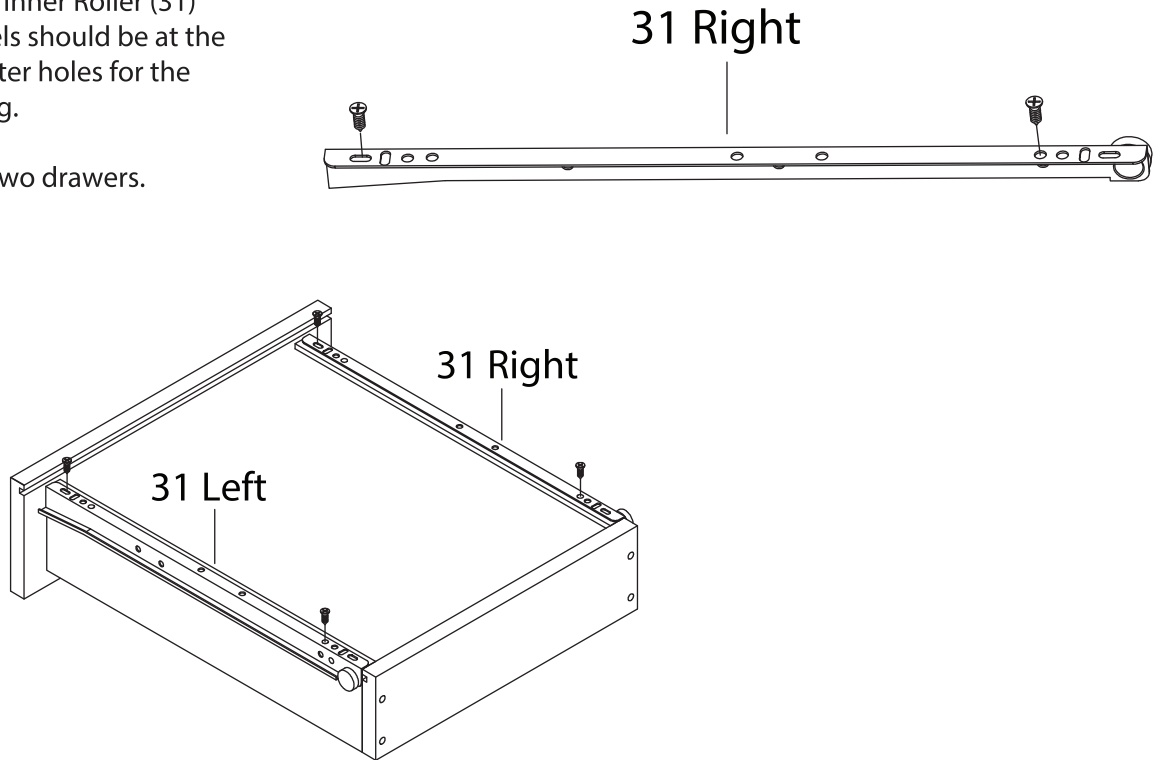

STEP 18

Align the inner and outer rollers and insert the drawers. Place the Stickers (K) over the exposed Cams.

 K x 24

