

ASSEMBLY INSTRUCTION FOR ACME FURNITURE

MODEL#OF00137

Thank you for purchasing the quality product. Be sure to check all packing material carefully for small parts which may have come loose inside the carton during shipment. Separate, identify and count all parts and metal hardware. Compare with all parts are present. If any part(s) are missing or damaged, please contact your local furniture dealer. For efficient and speedy service, please indicate the model number and code letter of part(s) needed.

*****Do not fully tighten screws until fully assembled.*****

DESK WITH TWO SHELVES

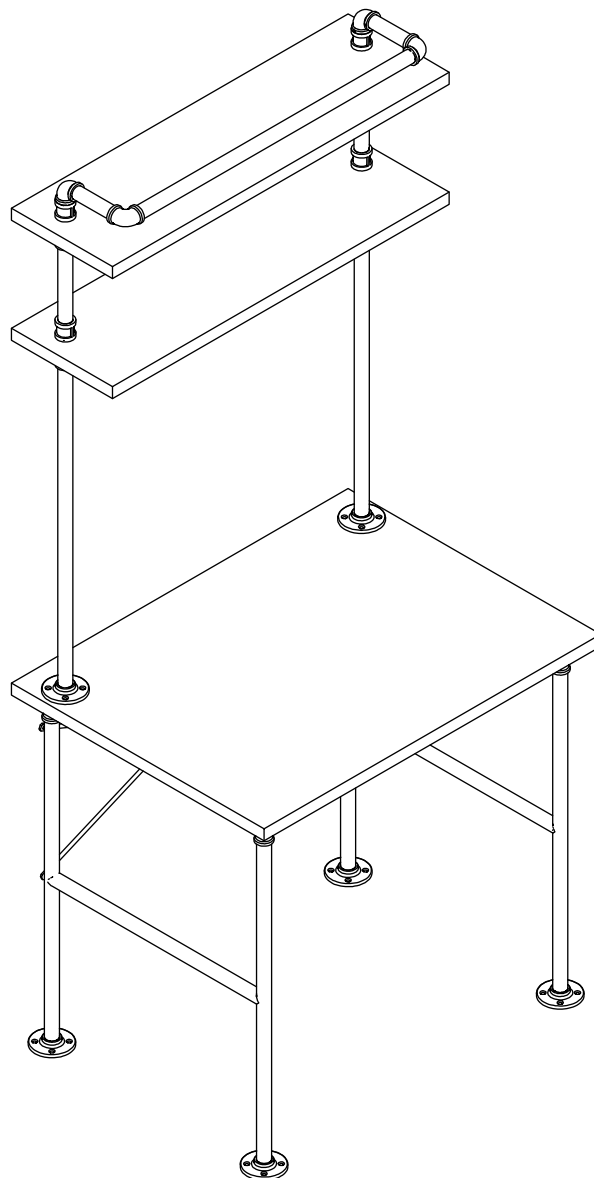

DIMENSIONS

Width - 31.5"
Depth - 23.62"
Height - 70.83"

ASSEMBLY INSTRUCTIONS

PRECAUTIONS

Because our products may be challenging for beginners, we deeply understand that you may encounter some difficulties. To avoid discouragement, we have provided some useful tips, as follows.

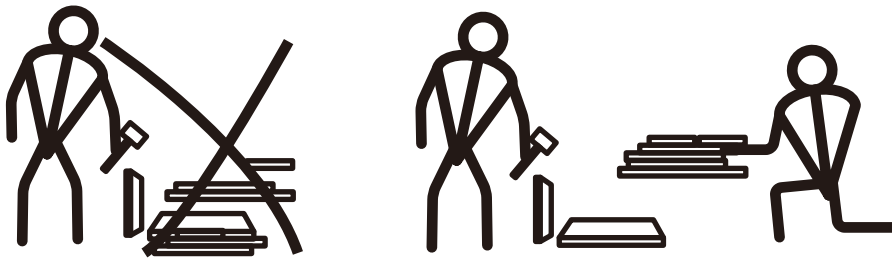

Enough Open Space -

Ensure that there is enough space for movement during assembly.

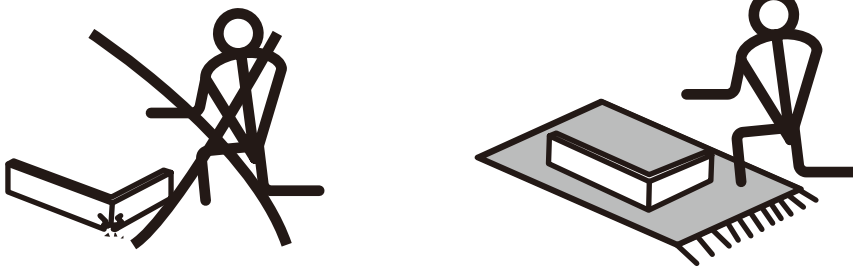

Prevent Scratching -

When assembling furniture, use cardboard, blankets or a carpet areas to prevent scratches.

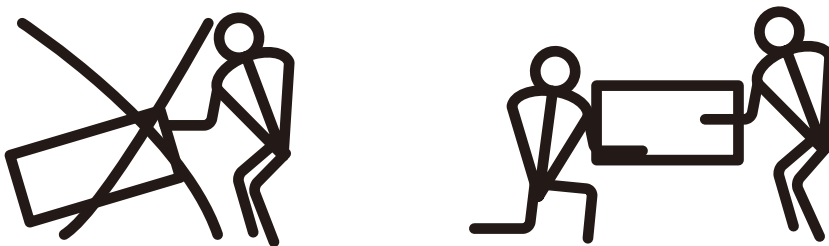

More than two people -

Always have at least two people to help transport and assemble the product to avoid potential injury and/or damage.



Question -

If there is any problem with the assembly process, you can call us.

OF00137

PARTS LIST

A X1 Top

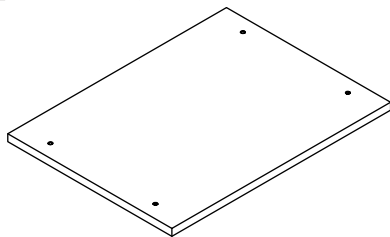

G X1 Iron pipe-672mm

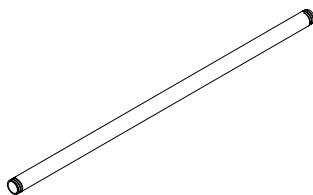

M X4 Pipe screw



B X1 Top shelf

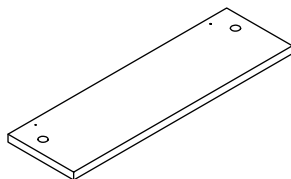

H X2 Iron pipe

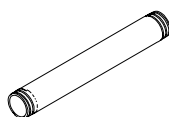

N X2 Pipe screw



C X1 Bottom shelf

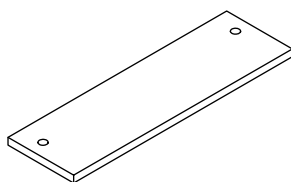

I X2 Iron pipe

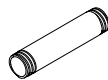

D X2 Frame

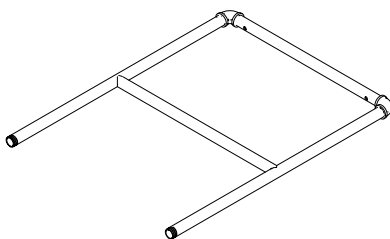

J X4 Elbow pipe joint

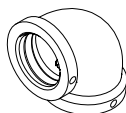

E X2 Iron rod



K X8 Pipe joint

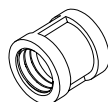

F X2 Iron pipe-680mm

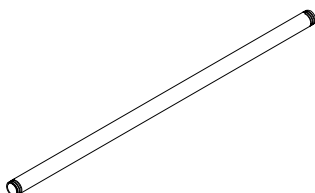

L X6 Flange

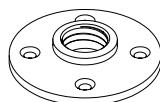

HARDWARE LIST

① X8 Wood screw 5/8"



② X8 Fixing screw 5mm



③ X4 U-shaped washer



④ X4 Bolt 45mm



⑤ X5 Bolt 12mm

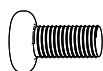

⑥ X1 Nut 5mm



⑦ X2 Iron sheets



⑧ X2 T-head screw 5/8"

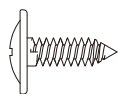

⑨ X2 Wall anchor 1-1/8"

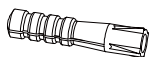

⑩ X2 T-head screw 1"

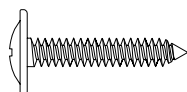

⑪ X1 Allen wrench

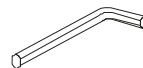

Attention

Some number parts listed on the instruction sheet may not be in parts bag as they may already be assembled. Carefully check parts and packing materials prior to ordering replacements.

ASSEMBLY INSTRUCTIONS

Step 1.

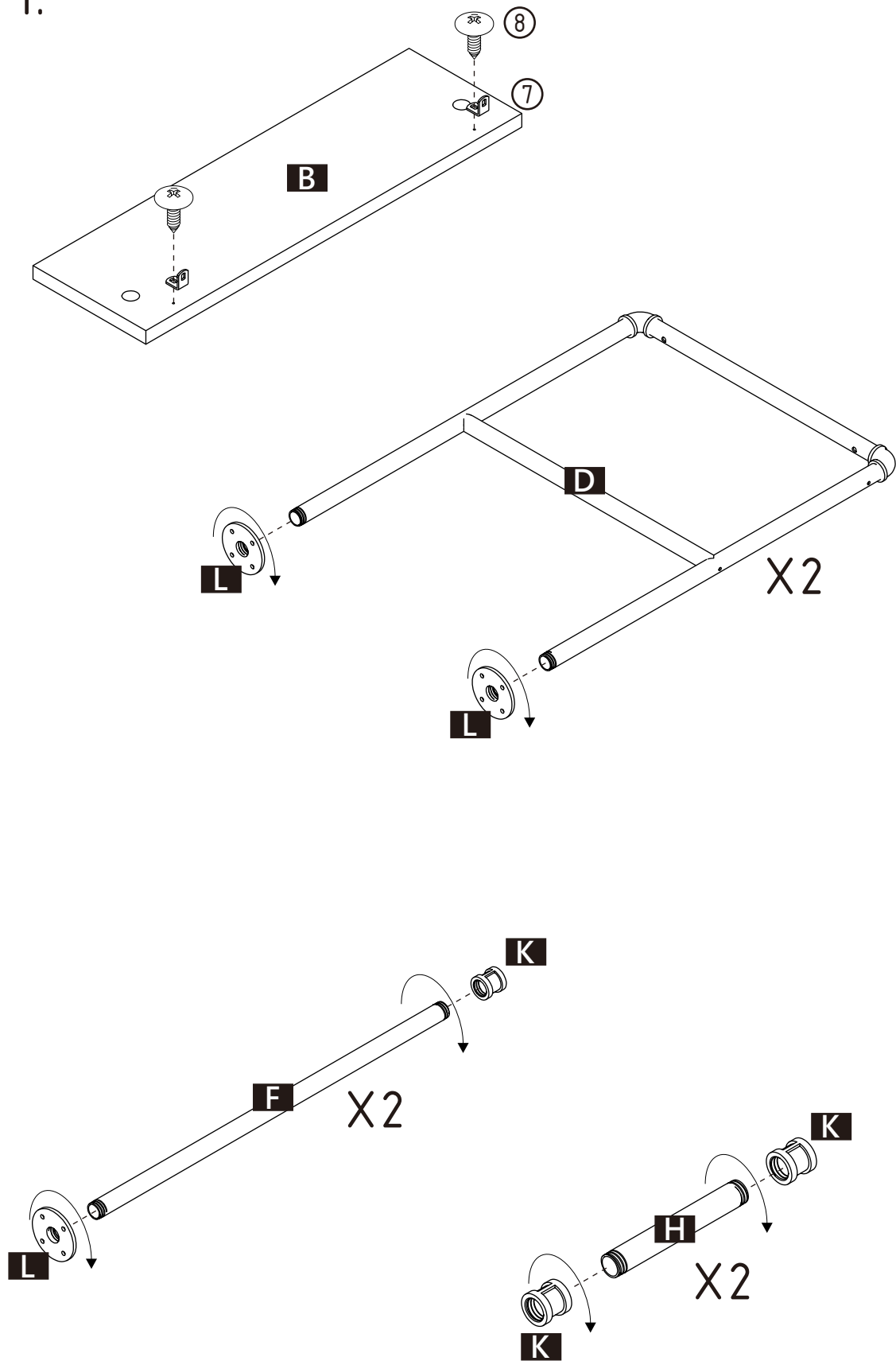

ASSEMBLY INSTRUCTIONS

Step 2.

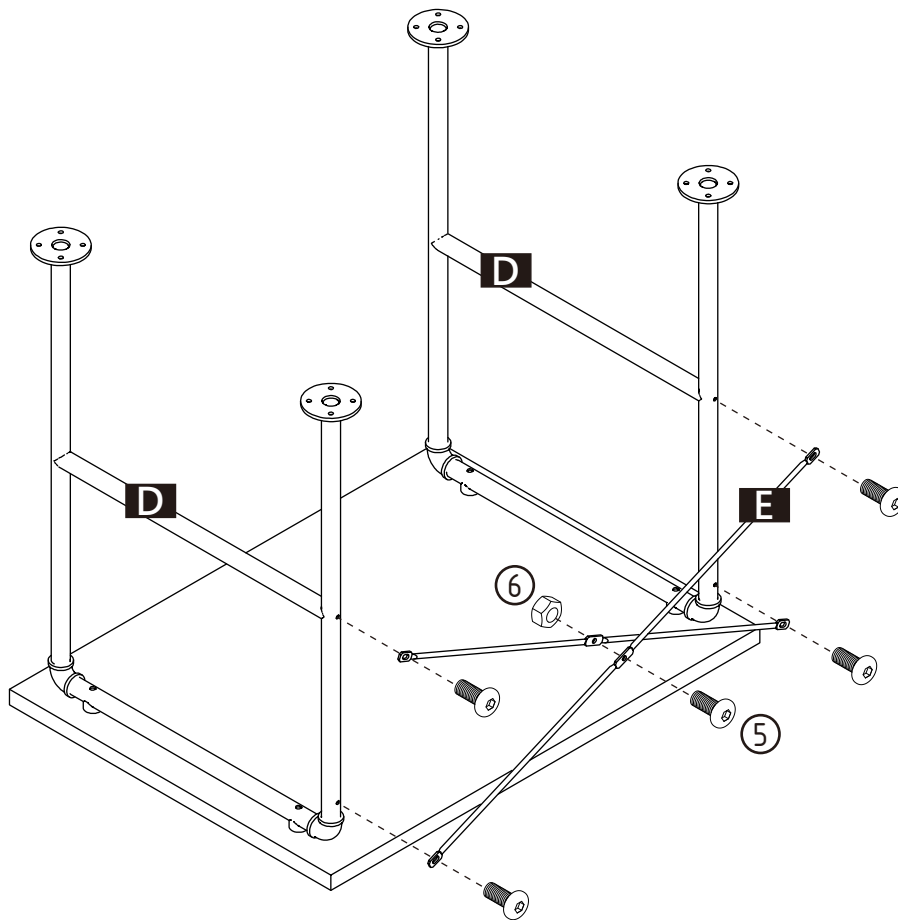
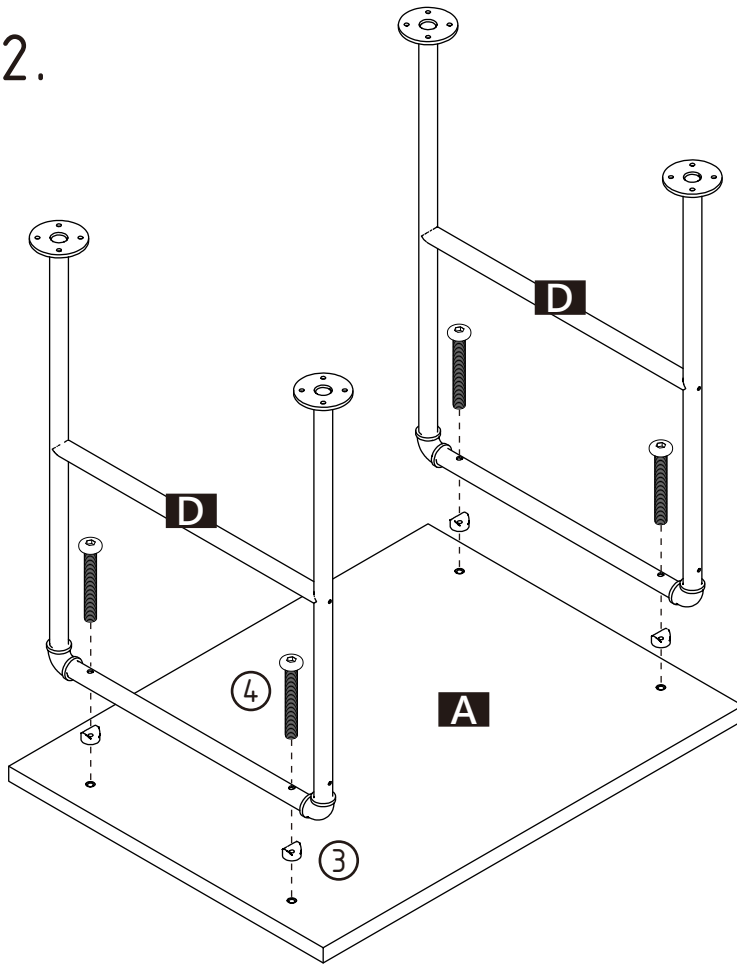

ASSEMBLY INSTRUCTIONS

Step 3.

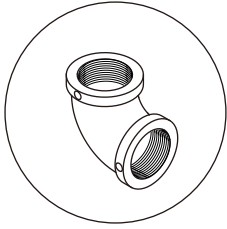

The hole in the elbow faces inward.

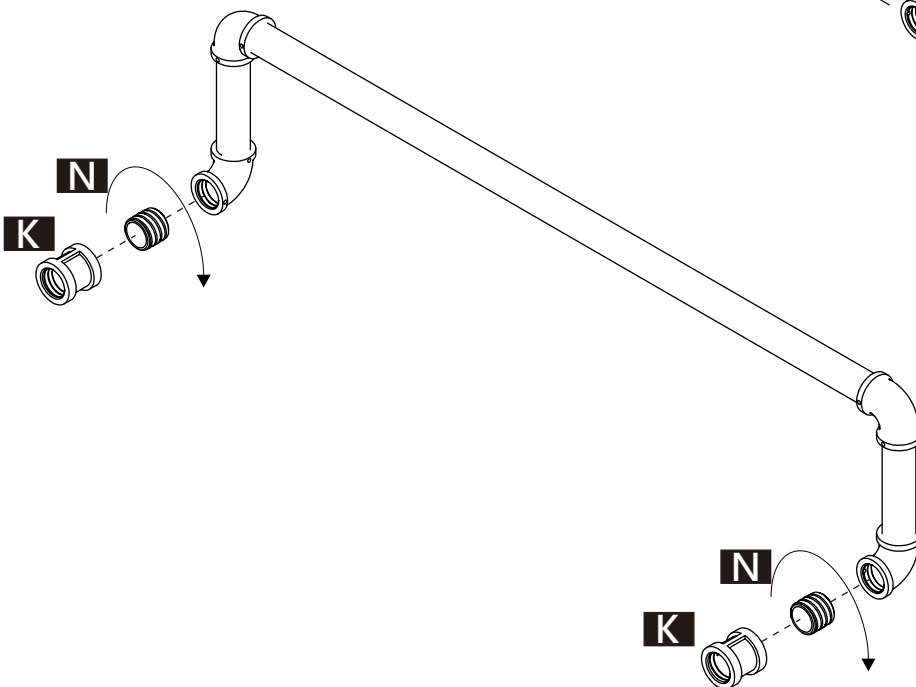
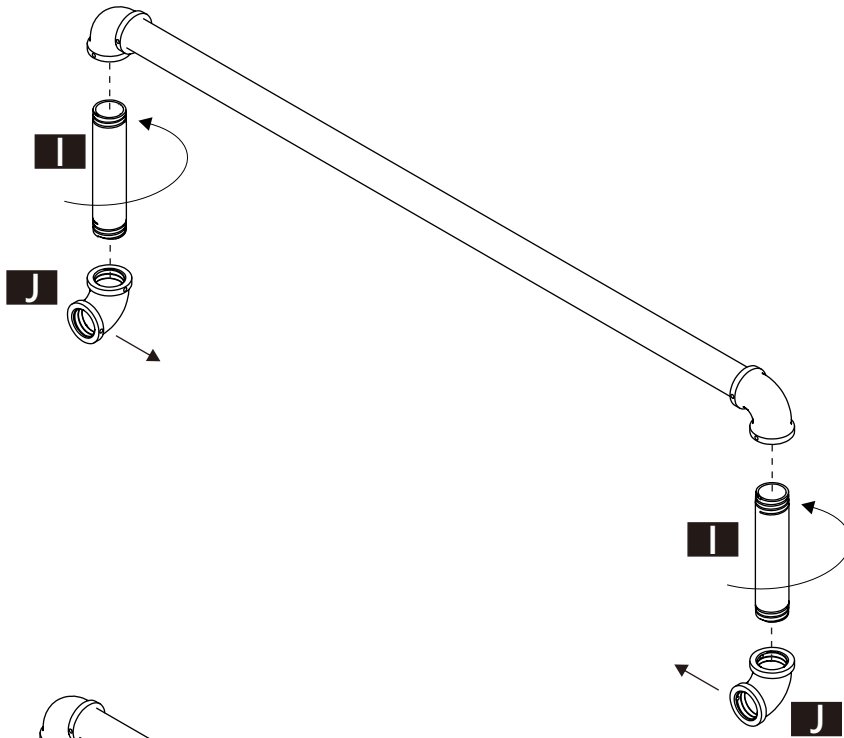
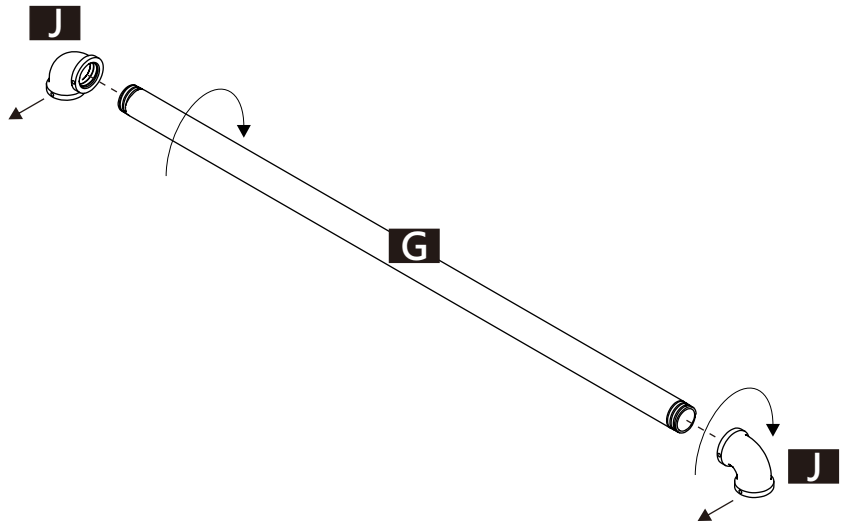

ASSEMBLY INSTRUCTIONS

Step 4.

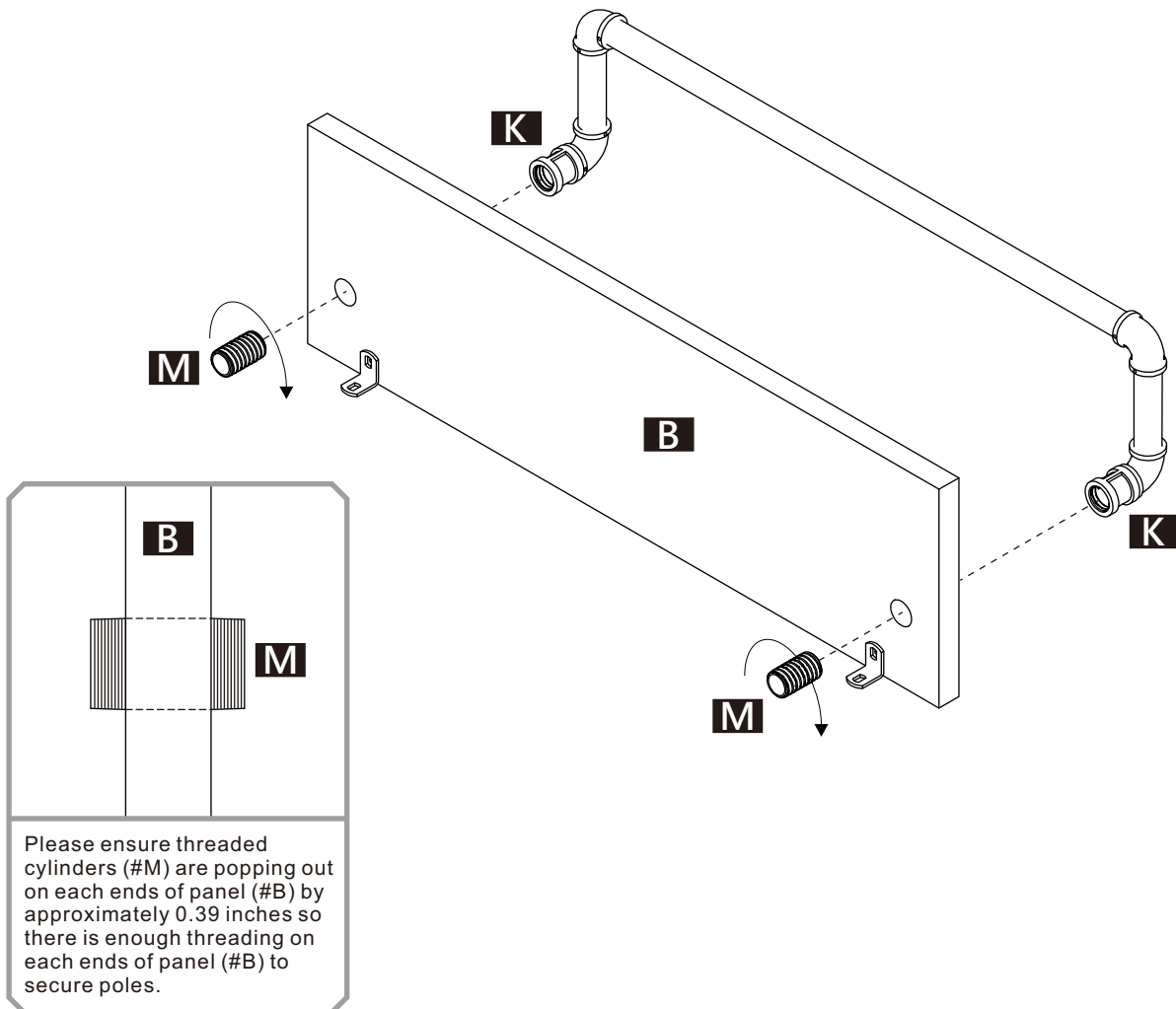
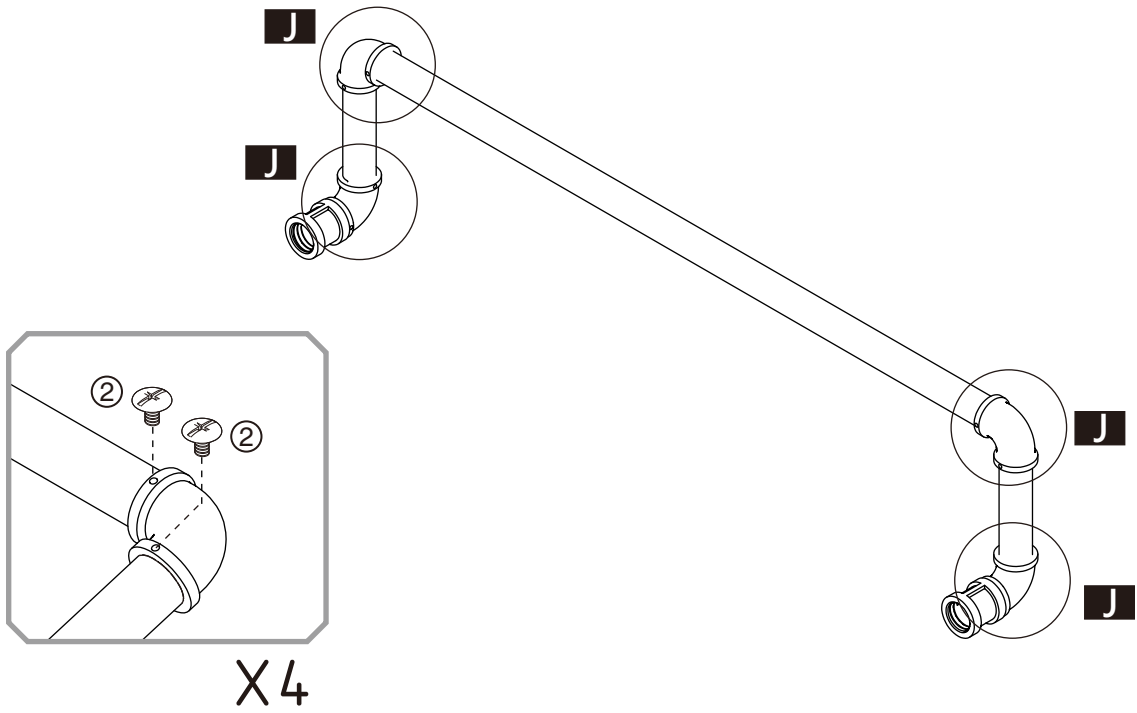

ASSEMBLY INSTRUCTIONS

Step 5.

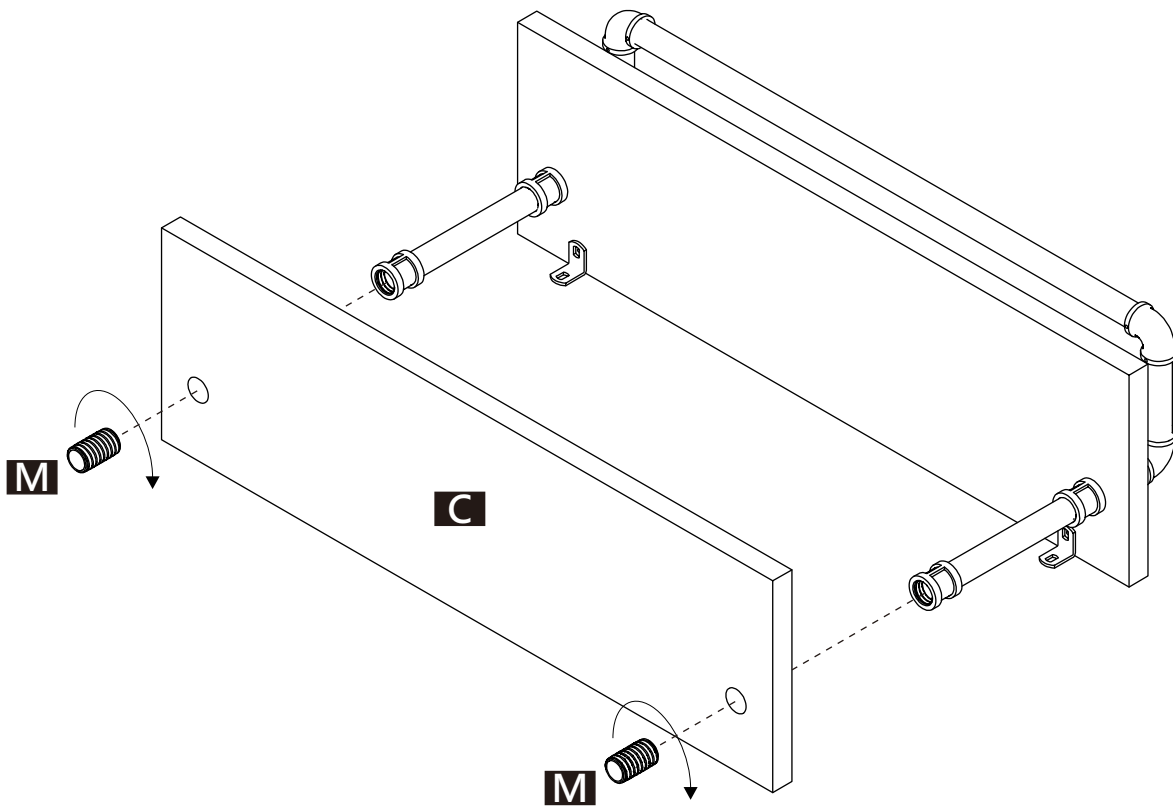
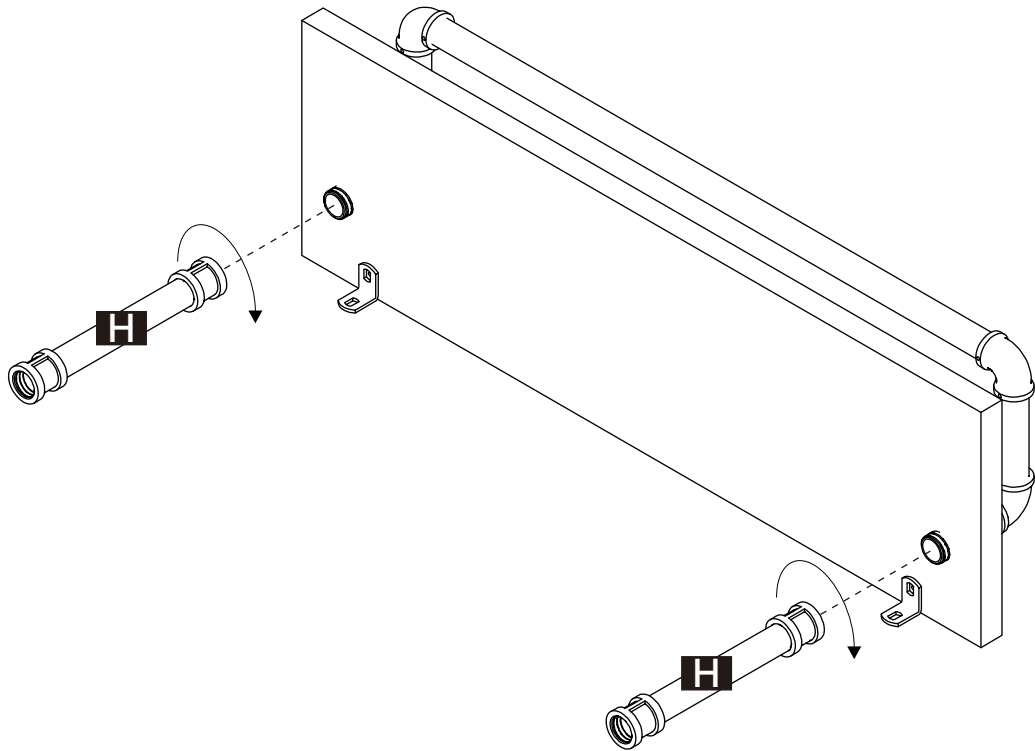

ASSEMBLY INSTRUCTIONS

Step 6.

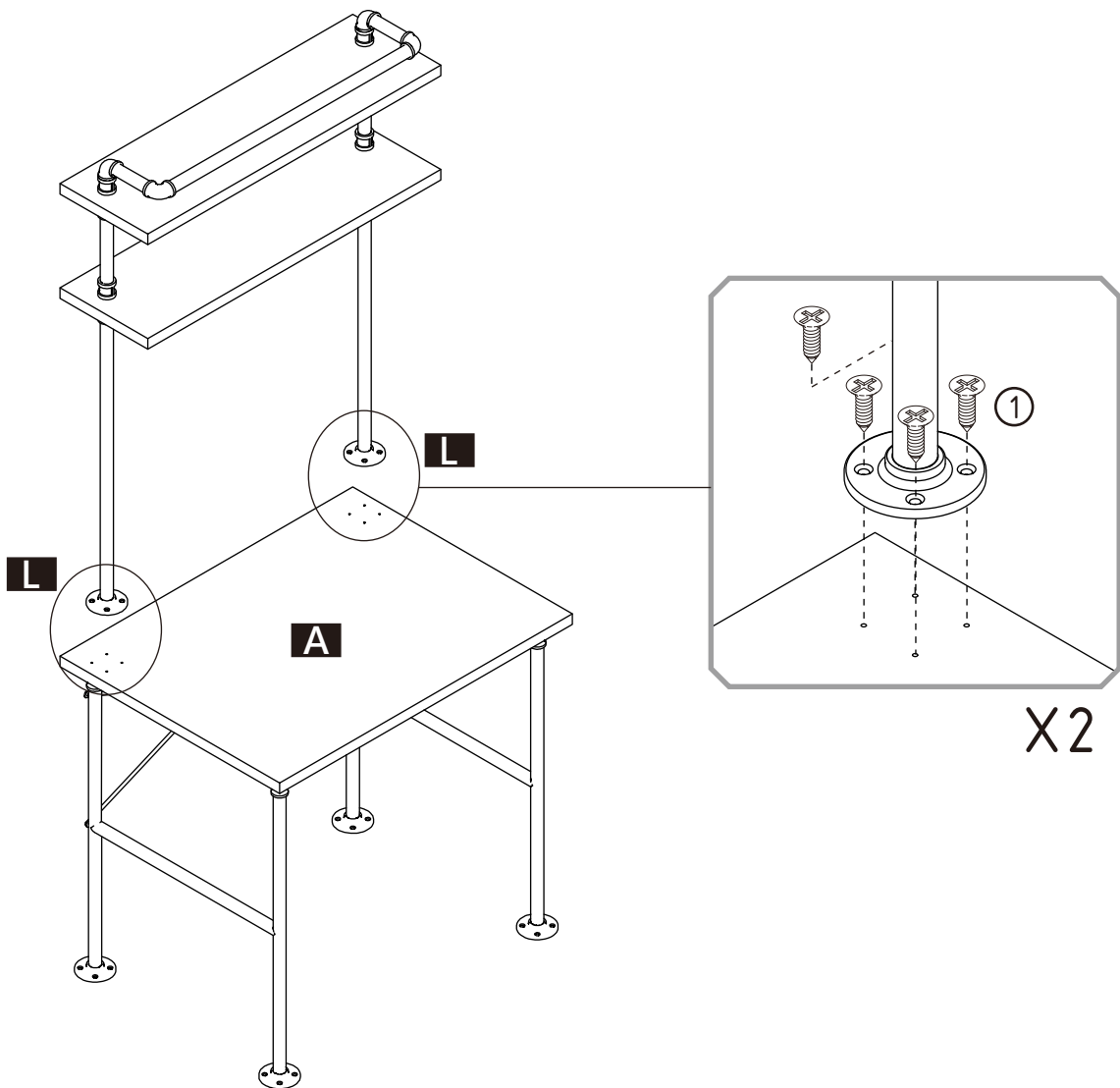
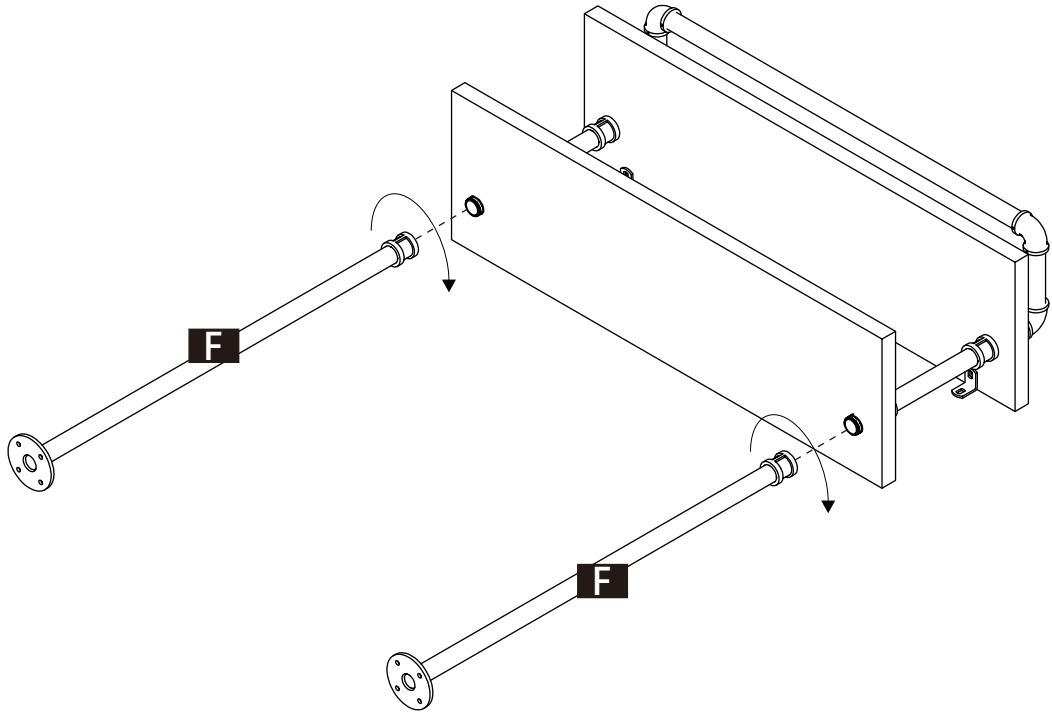

ASSEMBLY INSTRUCTIONS

Step 7.

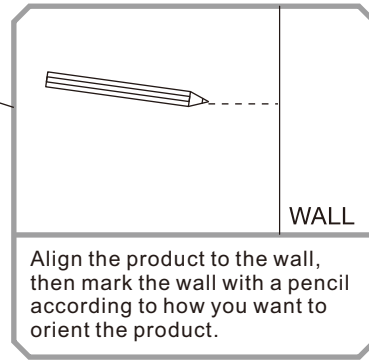
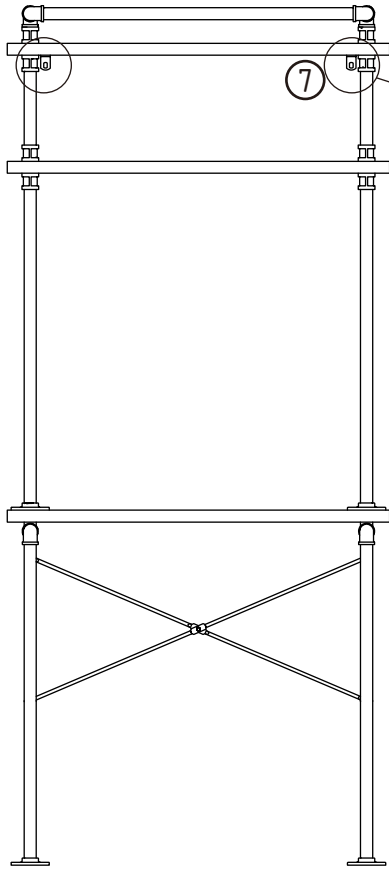

Align the product to the wall, then mark the wall with a pencil according to how you want to orient the product.

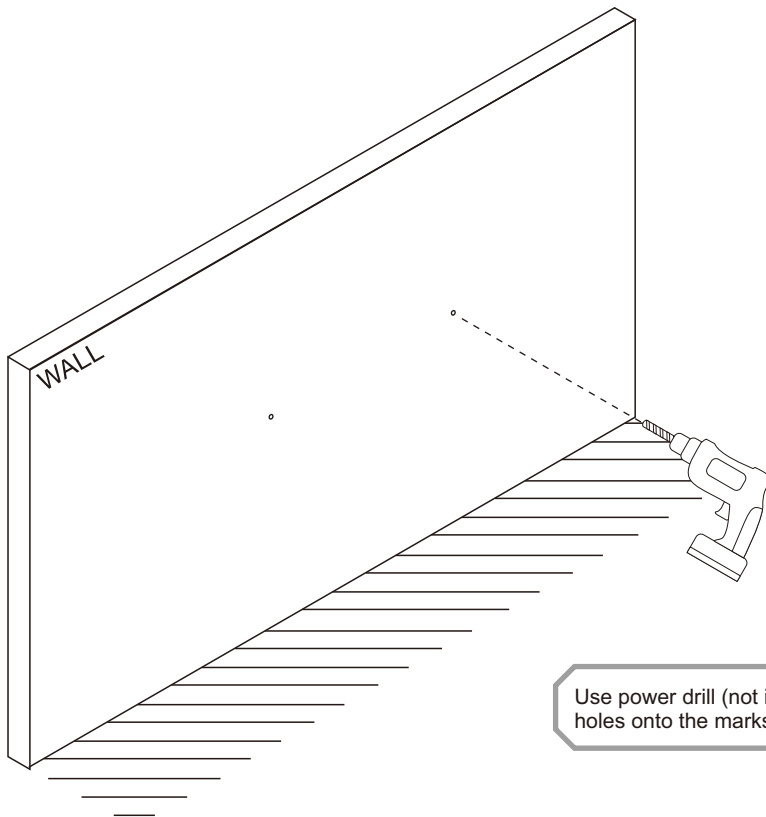

Use power drill (not included) to drill holes onto the marks on the wall.

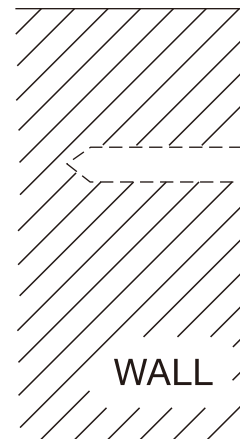

ASSEMBLY INSTRUCTIONS

Step 8.

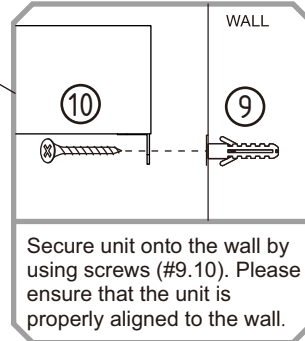
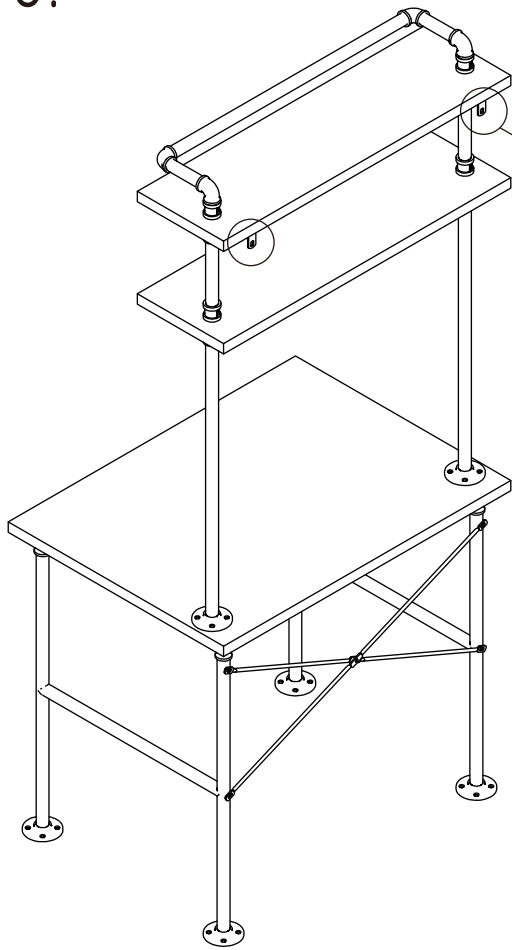

X2

ASSEMBLY IS COMPLETED.

Make sure the product is rested on a flat surface and does not feel loose or wobbly. If it does, double check that the bolts/screws are secured and properly tightened.