

BRASSTECH		2001 E. CARNEGIE AVE.
INCORPORATED		SANTA ANA, CA 92705
		(949) 417-5207
DWG NO.	2510-5203	REV H
SCALE .225	REF. -	SHEET 2 OF 3

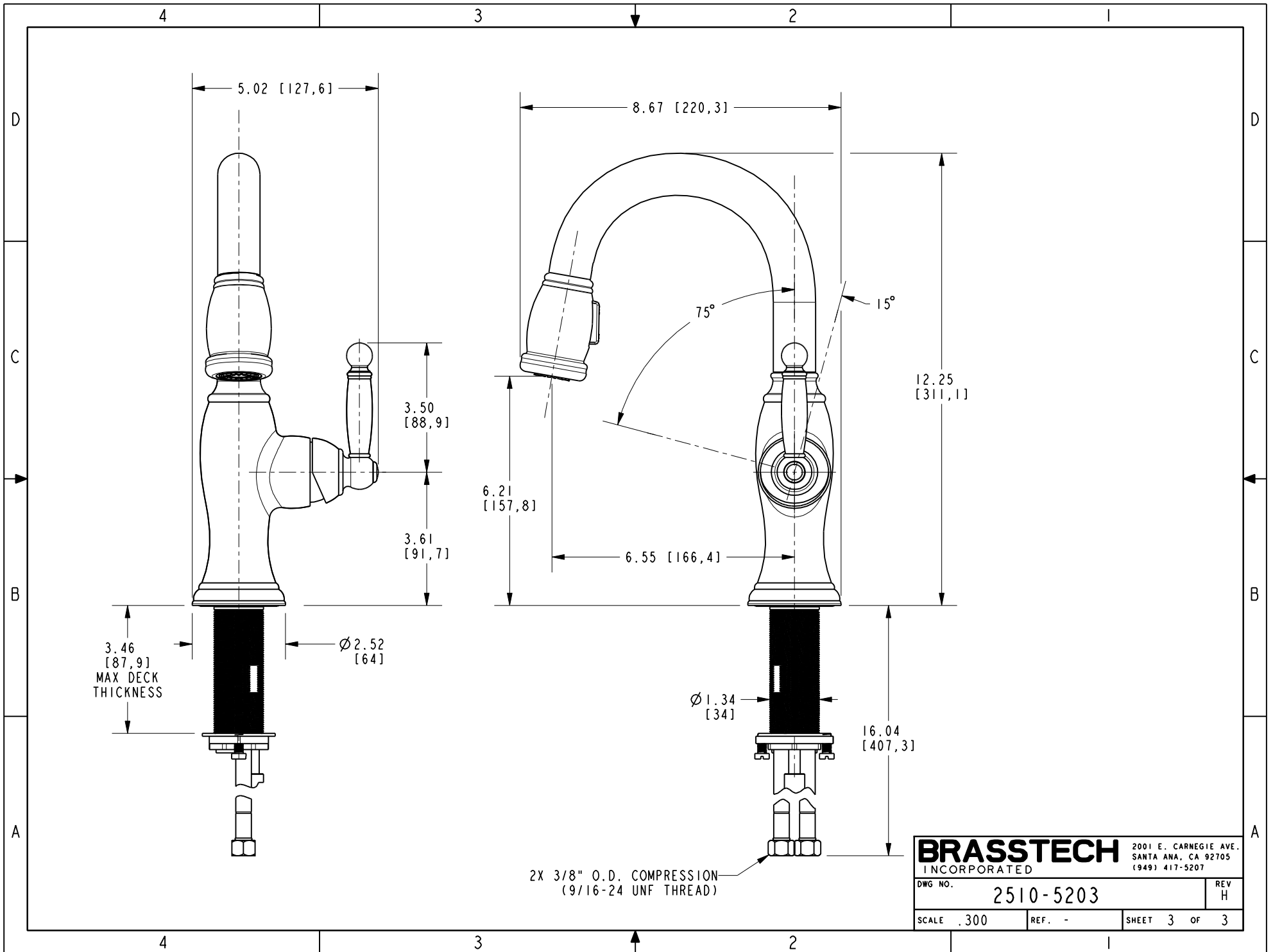

2X 3/8" O.D. COMPRESSION
(9/16-24 UNF THREAD)

BRASSTECH		2001 E. CARNEGIE AVE. SANTA ANA, CA 92705 (949) 417-5207	
DWG NO.	2510-5203	REV	H
SCALE	.300	REF.	-
SHEET 3		OF 3	