

## ASSEMBLY INSTRUCTION

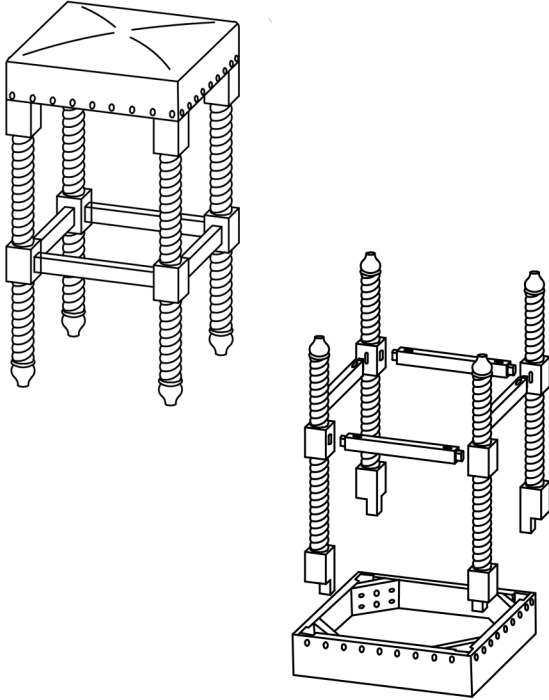

## PARTS CHECK LIST

CODE	COMPONENTS	Q'TY
(A)	SEAT FRAME	x01
(B)	RIGHT LEG	x02
(C)	LEFT LEG	x02
(D)	STRETCHER	x04

## FITTINGS CHECK LIST

CODE	DESCRIPTION	Q'TY
(E)	 JCBC M6 x 60mm	x08
(F)	 SPRING WASHER Ø1/4"	x08
(G)	 FLAT WASHER Ø1/4" 19mm	x08
(H)	 PH SCREW M4 x 38mm	x08
(I)	 L-KEY M4 x 65mm	x01

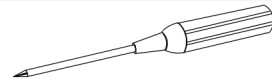

PHILLIPS HEAD SCREWDRIVER  
TOOL NEEDED (NOT INCLUDED)

1. Attach stretchers (D) to left legs (C) to right legs (B). Use screw (H) to tighten the stretchers (D) to the left legs (C) and right legs (B) with Phillips head screwdriver.

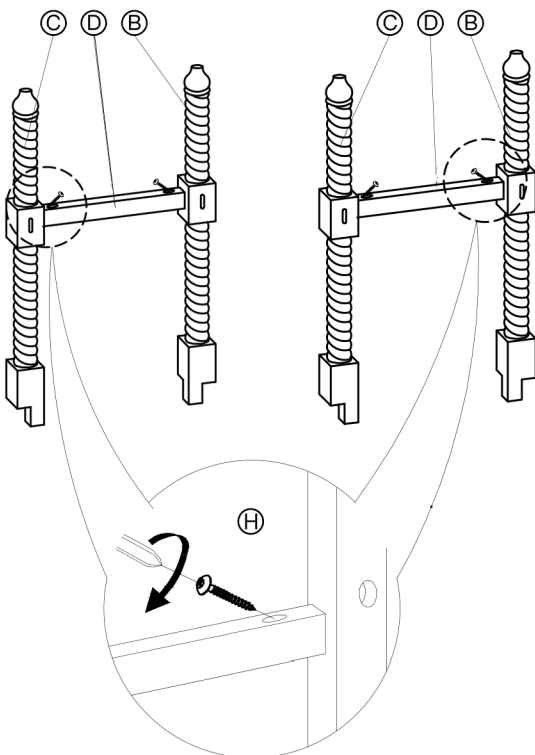

2. Place seat frame (A) upside down on a non-abrasive surface. Insert one leg assembly to seat frame (A). Use bolts (E), spring washer (F), flat washer (G) to tighten on each side with Allen key (I).

**Do not tighten bolts (E) all the way**

**Please note: The fabric cover on seat frame upside is held in place with velcro. you will need to pull the fabric cover out in order to expose the screw holes**

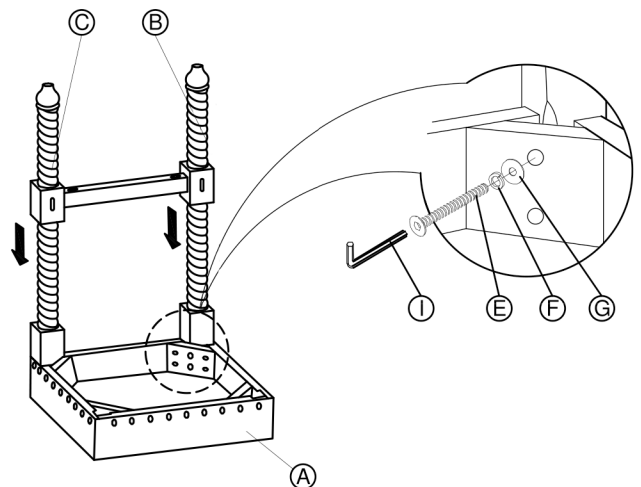

3. Attach stretchers (D) to both legs. Use screws (H) to tighten stretchers to both legs with Phillips head screwdriver.

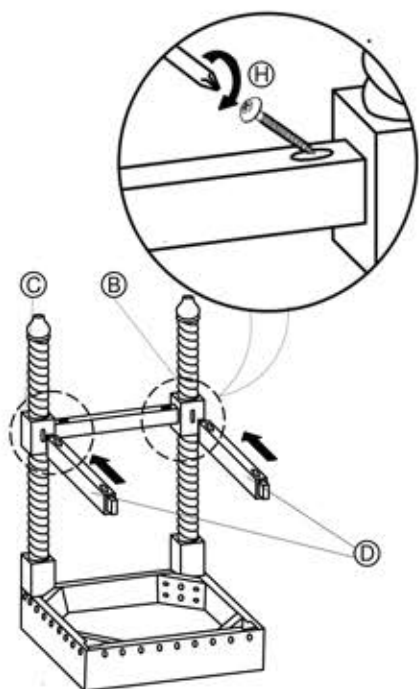

4. Insert second leg assembly to seat frame (A), stretchers (D) as shown. Use bolts (E), spring washer (F), and flat washer (G) to tighten leg assembly to seat frame (A) with Allen key (I).

Do not tighten bolts (E) all the way.

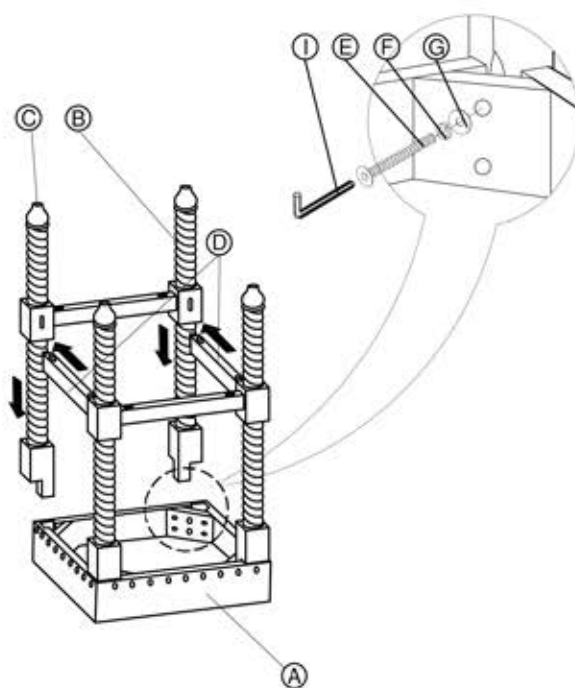

5. Use screws (H) to tighten the stretchers (D) to the leg assembly with Phillips head screwdriver.

At this stage tighten all screws and bolts all the way 100% then stick fabric cover to velcro again

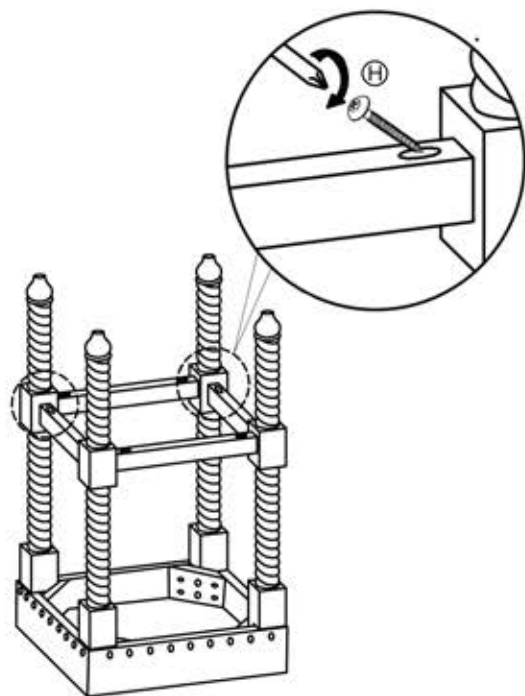

6. Assembly is complete.

