

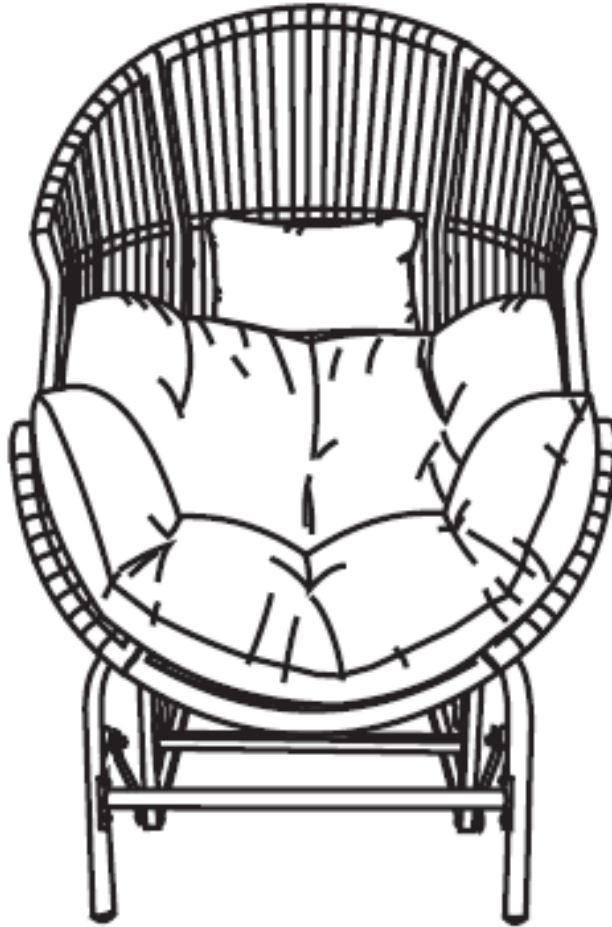









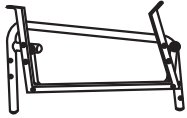

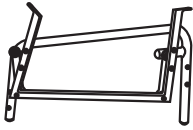



Assembly Instructions

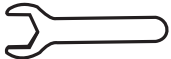

***Don't fully tighten all the bolts till the very end!**

PRE-ASSEMBLY PREPARATION:

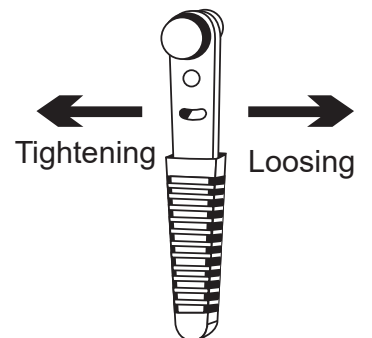
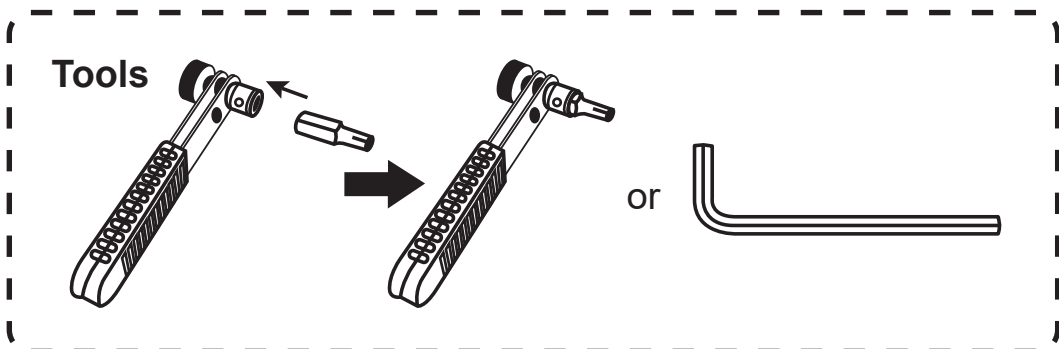

- Please read through the instructions before beginning assembly.
- Clear out the space for assembly and lay out all of the parts based on the Parts List, extra room will allow you to easily determine if all the pieces are present.
- Keep small parts and pieces away from children until fully assembled.

Part no.	Part	QTY	Image	Part no.	Part	QTY	Image
A	Right leg	1		J	Bolt (M6*60mm)	2	
B	Left leg	1		K	Bolt (M6*18mm)	20	
C	Long connecting rod	2		L	Nut	12	
D	Short connecting rod	2		M	Washer	44	
E	Back	1		N	Allen wrench	1	
F	Seat	1		O	Wrench	1	
G	Right panel	1		P	Seat cushion	2	
H	Left panel	1		Q	head cushion	1	
I	Bolt (M6*52mm)	10		R	Ratchet wrench	1	



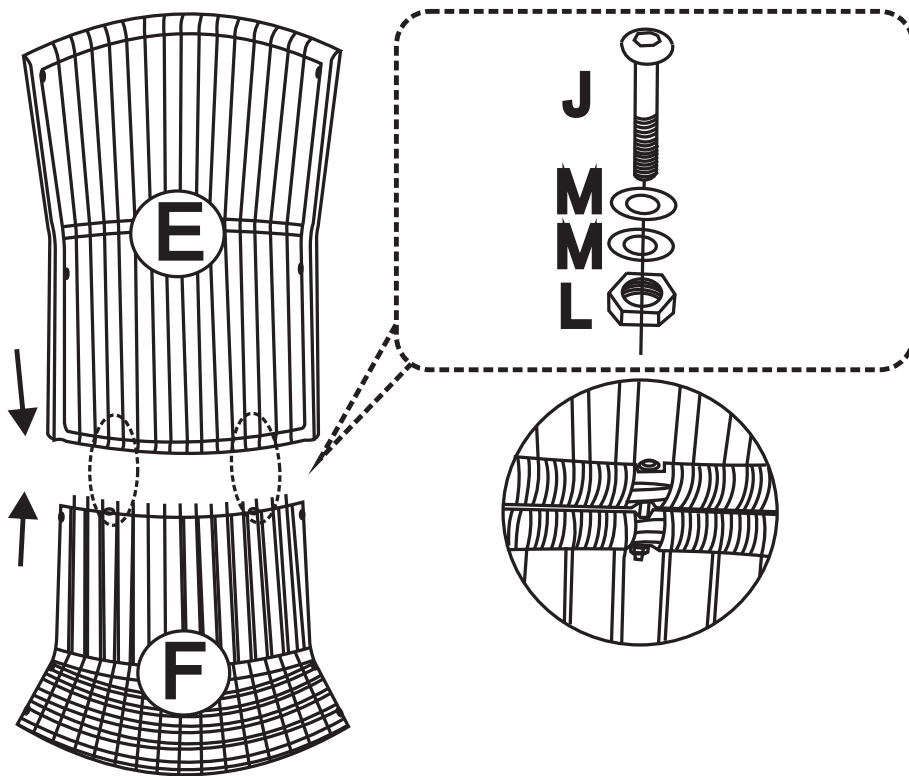

Step 1: Attach part E&F with 2pcs bolts J, 4pcs washers M and 2pcs nuts L, using Allen wrench N and wrench Q. Note: Don't fully tighten the bolts.



L		M6	2
M		M6	4
J		M6X60MM	2

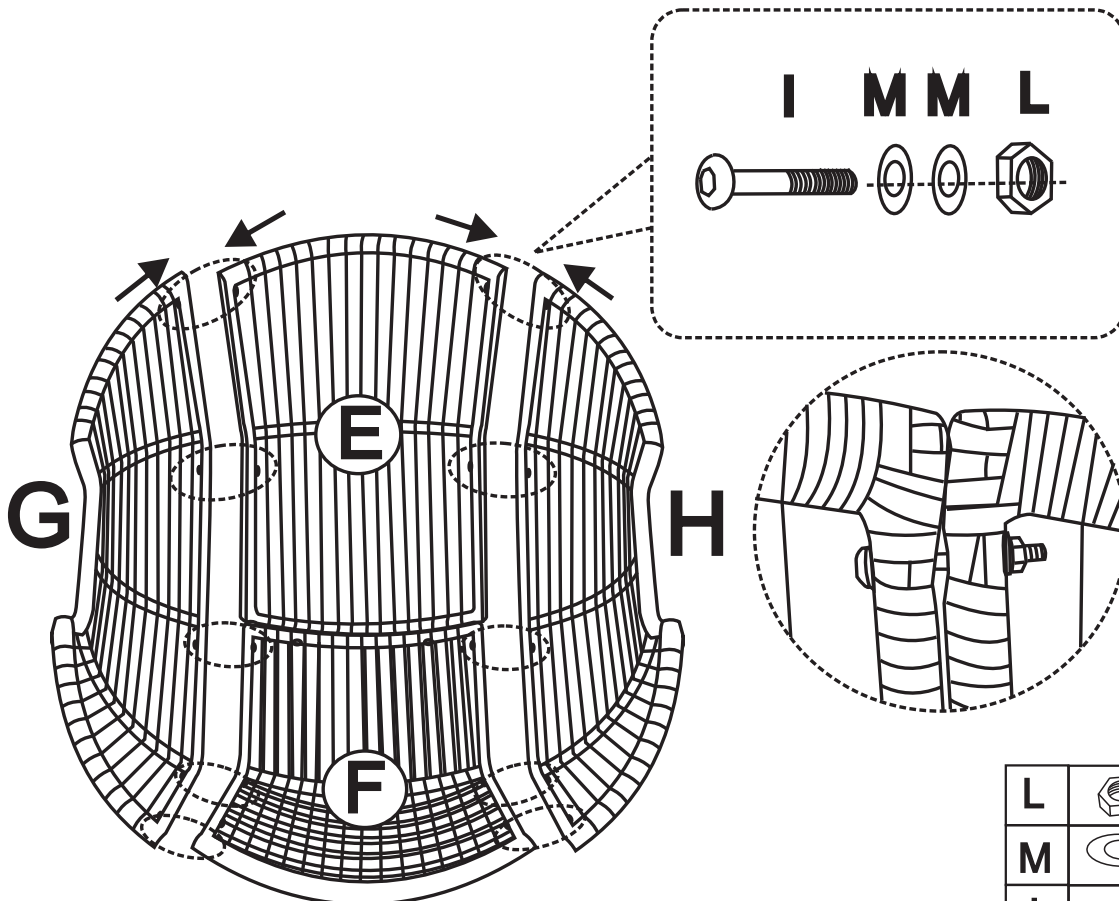

Step 2: Attach part G&H to part E&F with 10pcs bolts I, 20pcs washers M and 10pcs nuts L, using Allen wrench N and wrench Q. Note: Don't fully tighten the bolts.

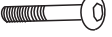

L		M6	10
M		M6	20
I		M6X52MM	10

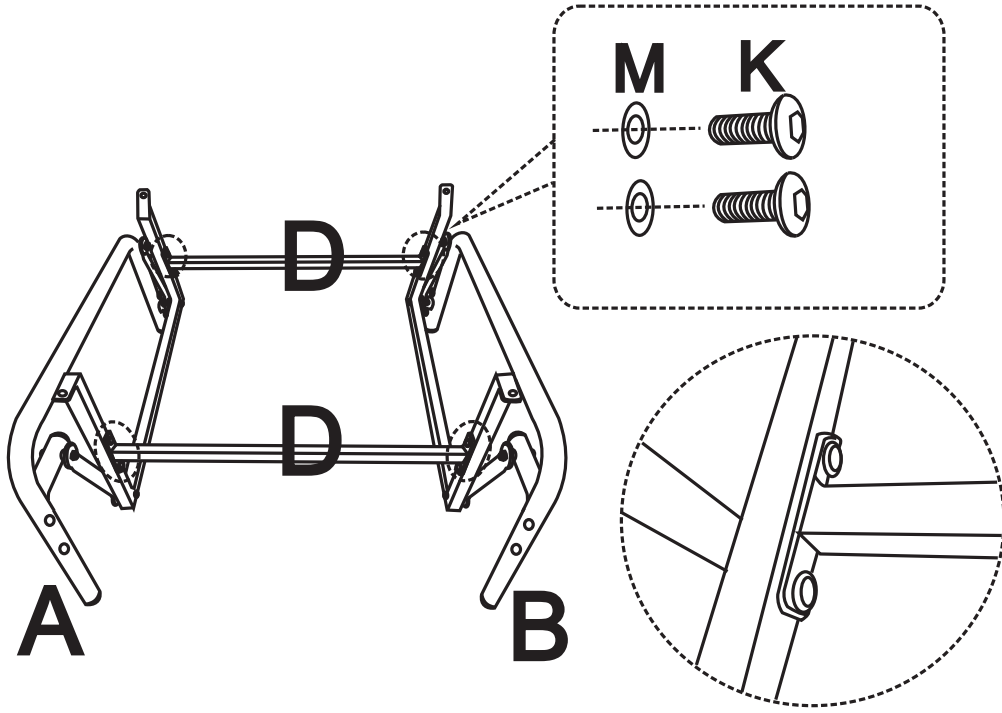

Step 3: Attach 2pcs part D to part A&B with 8pcs bolts K and 4pcs washers M, using Allen wrench N. Note: Don't fully tighten the bolts.

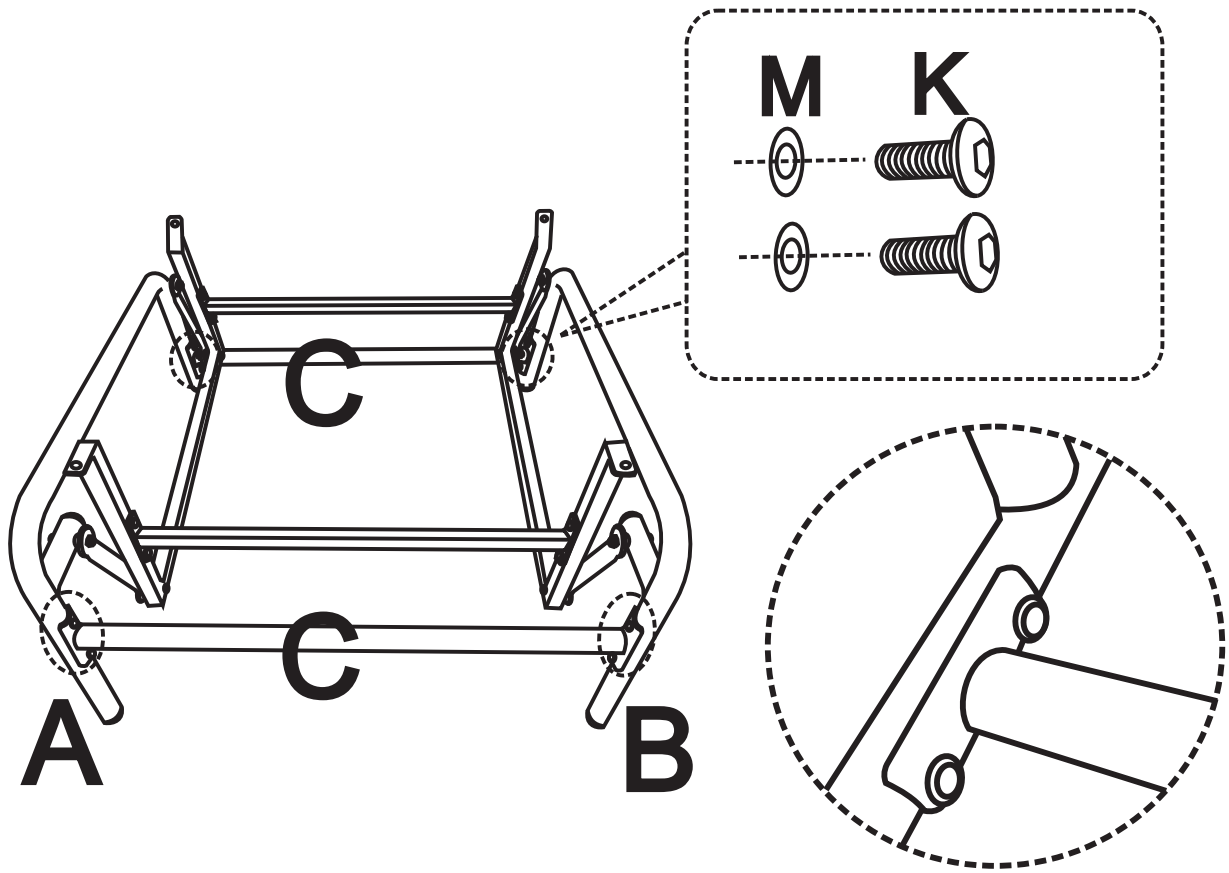

M		M6	8
K		M6X18MM	8

Step 4: Attach 2pcs part C to part A&B with 8pcs bolts K and 8pcs washers M, using Allen wrench N. Note: Don't fully tighten the bolts.



M		M6	8
K		M6X18MM	8

Step 5: Attach feet to part F with 4pcs bolts K and 4pcs washers M, using Allen wrench N. Note: Please fully tighten all the bolts.

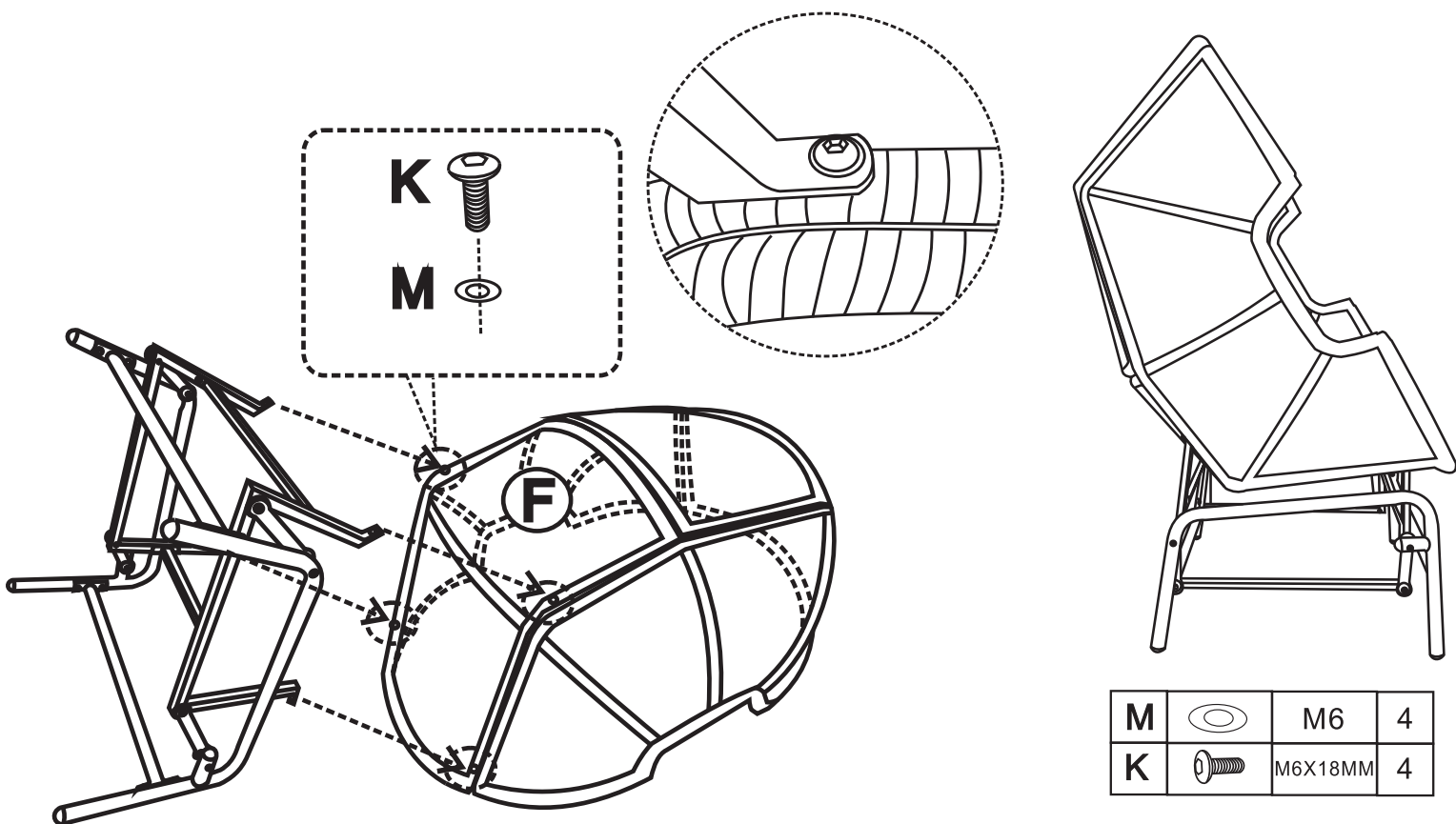

Step 6: Tie seat cushions P and head cushion Q onto the seat .
Assembly is now complete and the product is ready for use.

