

ASSEMBLY INSTRUCTION

PLEASE READ BEFORE ASSEMBLING!

Tip #1: Make sure you've taken all the pieces and hardware out of its packaging before discarding the box.



Tip #2: Using page 2 and/or page 3 of instruction manual make sure all pieces and hardware are accounted for.

Tip #3: Read manual before assembling, it helps!

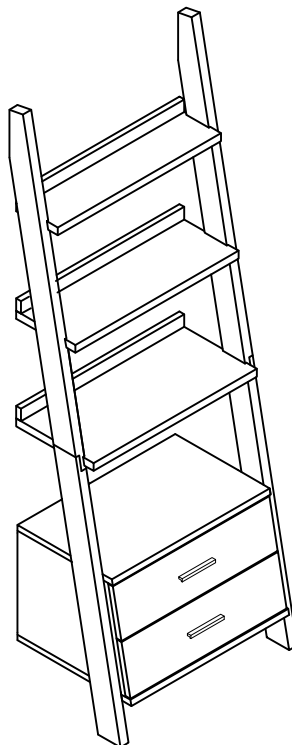
ITEM#:2562 2755



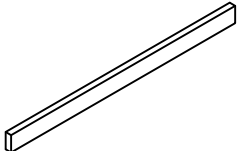
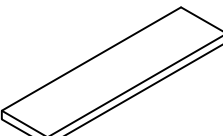
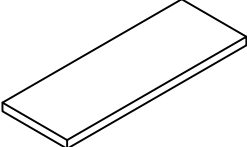
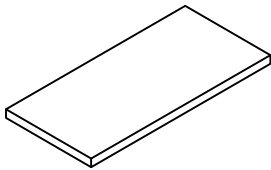

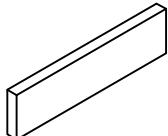
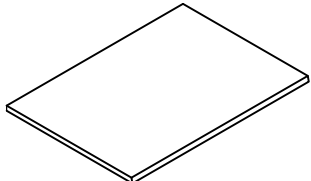
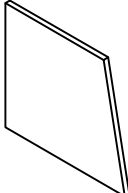
IDENTIFICATION DES PIÈCES
PARTS IDENTIFICATION

1		BARRE BAR	3MCX/PCS
2		TABLETTE SHELF	1MC/PC
3		TABLETTE SHELF	1MC/PC
4		TABLETTE SHELF	1MC/PC
5		BARRE TRANSVERSALE DU BAS BOTTOM CROSSBAR	1MC/PC
6		BARRE TRANSVERSALE DU BAS BOTTOM CROSSBAR	1MC/PC
7		PANNEAU DU BAS BOTTOM PANEL	1MC/PC
8		PANNEAU CÔTÉ GAUCHE LEFT SIDE PANEL	1MC/PC

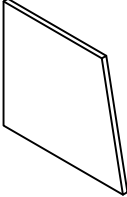
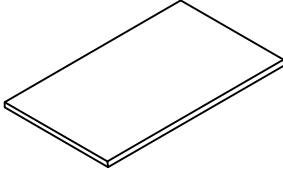
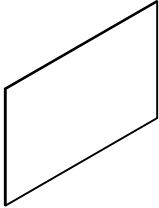
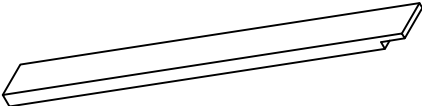
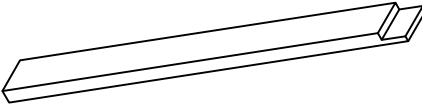
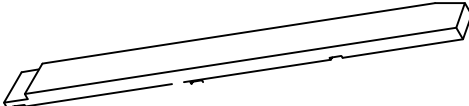
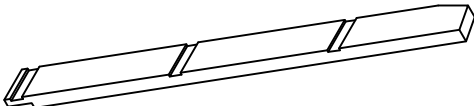



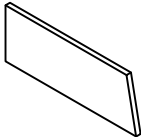
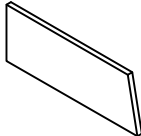
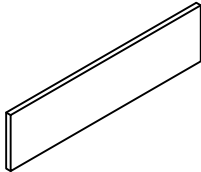
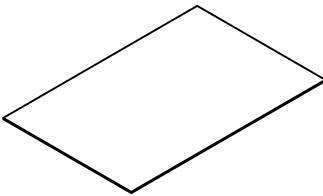
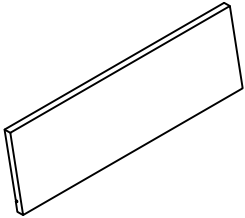



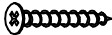

IDENTIFICATION DES PIÈCES
PARTS IDENTIFICATION

9		PANNEAU CÔTÉ DROIT RIGHT SIDE PANEL	1MC/PC
10		PANNEAU DU DESSUS TOP PANEL	1MC/PC
11		PANNEAU ARRIÈRE BACK PANEL	1MC/PC
12		PATTE LEG	1MC/PC
13		PATTE LEG	1MC/PC
14		PATTE LEG	1MC/PC
15		PATTE LEG	1MC/PC

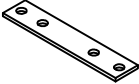









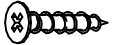
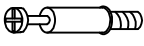

IDENTIFICATION DES PIÈCES
PARTS IDENTIFICATION

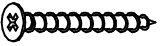
16		PANNEAU COTÉ DU TIROIR DRAWER SIDE PANEL	2MCX/PCS
17		PANNEAU COTÉ DU TIROIR DRAWER SIDE PANEL	2MCX/PCS
18		PANNEAU ARRIÈRE DU TIROIR DRAWER BACK PANEL	2MCX/PCS
19		PANNEAU DU FOND DU TIROIR DRAWER BOTTOM PANEL	2MCX/PCS
20		PANNEAU DEVANT DU TIROIR DRAWER FRONT PANEL	2MCX/PCS
21		SUPPORT DE TIROIR DRAWER SUPPORT	2MCX/PCS

IDENTIFICATION DES PIÈCES DE MONTAGE
HARDWARE IDENTIFICATION

A		L=29mm	4MCX/PCS
B		Ø15mm	4MCX/PCS
C		Ø8×25mm	16MCX/PCS
D		Ø4×30mm	8MCX/PCS
E		Z1016	20MCX/PCS
F		170×24×3mm(BLK)	2MCX/PCS
G		Ø6×12mm	8MCX/PCS
H		Ø6×55mm	8MCX/PCS
I		Ø10×15mm	8MCX/PCS
J		M4mm	1MC/PC
K		ø22mm	8MCX/PCS
L		Ø6×25mm	8MCX/PCS

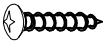
IDENTIFICATION DES PIÈCES DE MONTAGE
HARDWARE IDENTIFICATION

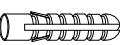
M		Ø4×25mm	4MCX/PCS
N		L=12mm	8MCX/PCS
O		Ø12mm	8MCX/PCS
P		Ø6×30mm	8MCX/PCS
Q		96mm	2MCX/PCS
R		Ø4×22mm	4MCX/PCS
T		Ø4×35mm	8MCX/PCS
U		Ø16mm	4MCX/PCS
V		Ø3.5x12mm	24MCX/PCS
W		Ø16mm	5MCX/PCS
X		197×5×1mm	1MC/PC
Y		12×12×1mm	2MCX/PCS
Z		Ø4×25mm	1MC/PC
A1		Ø5×40mm	1MC/PC
A2		Ø8×40mm	1MC/PC

2562 2755

ÉTAPE / STEP 1

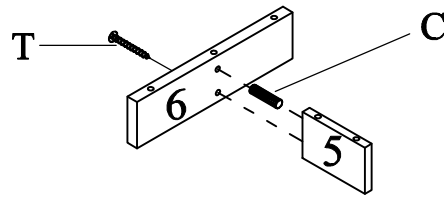

ÉTAPE / STEP 2

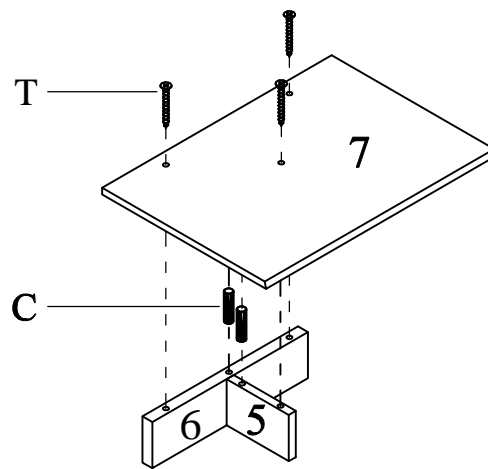

ÉTAPE / STEP 3

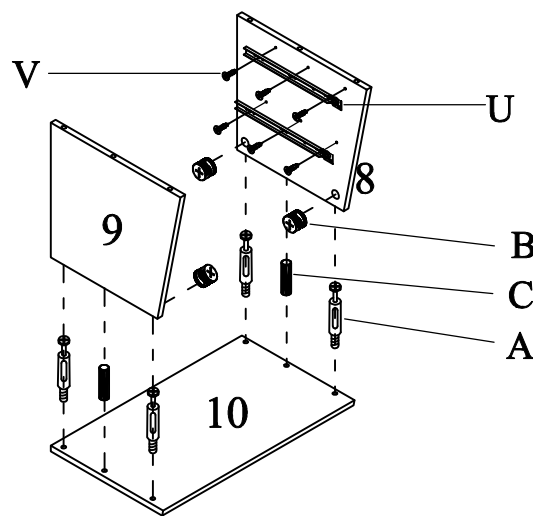

2562 2755

ÉTAPE / STEP 4

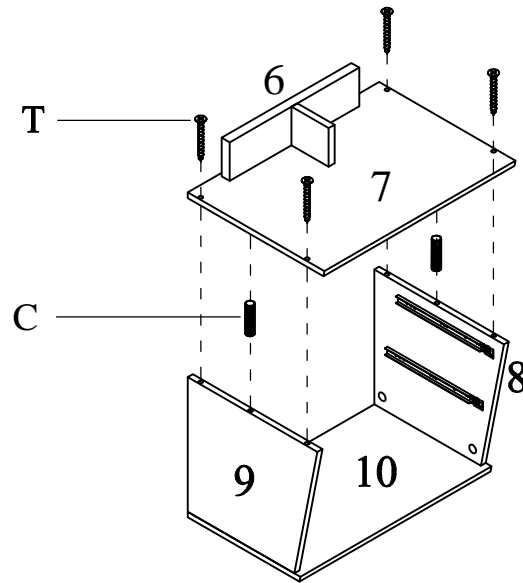

ÉTAPE / STEP 5

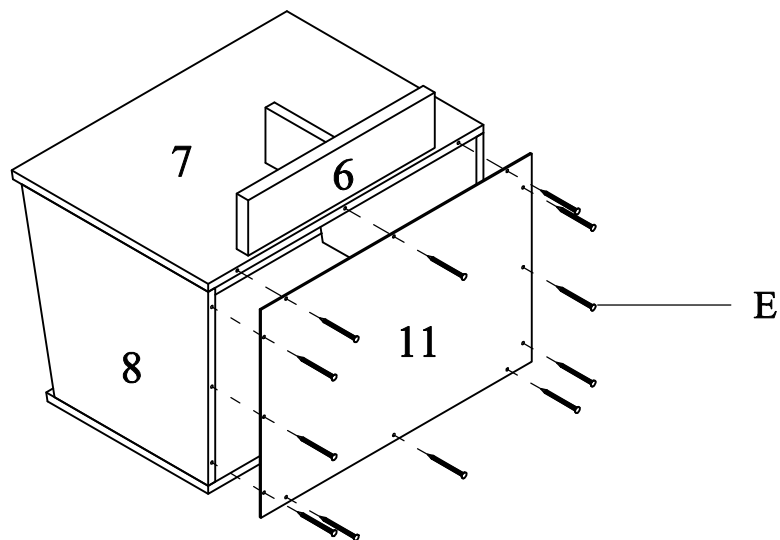

ÉTAPE / STEP 6

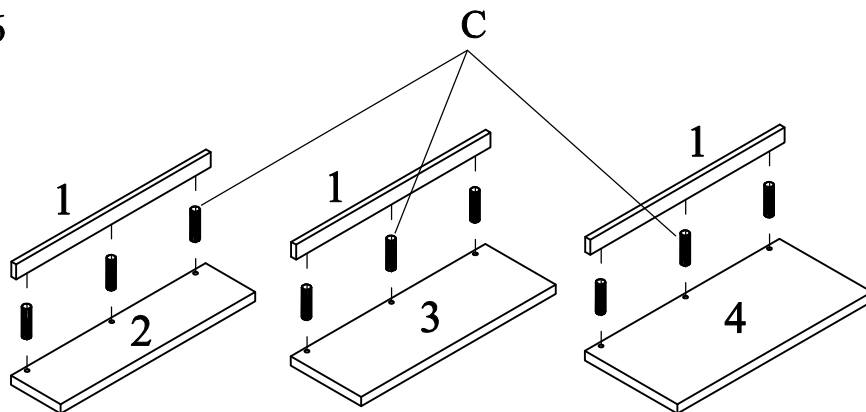

2562 2755

ÉTAPE / STEP 7

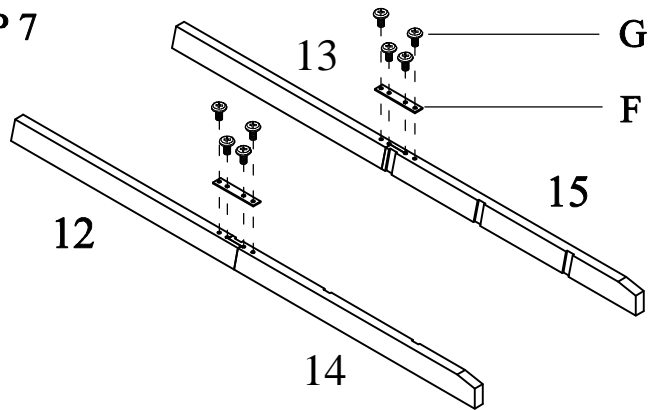

ÉTAPE / STEP 8

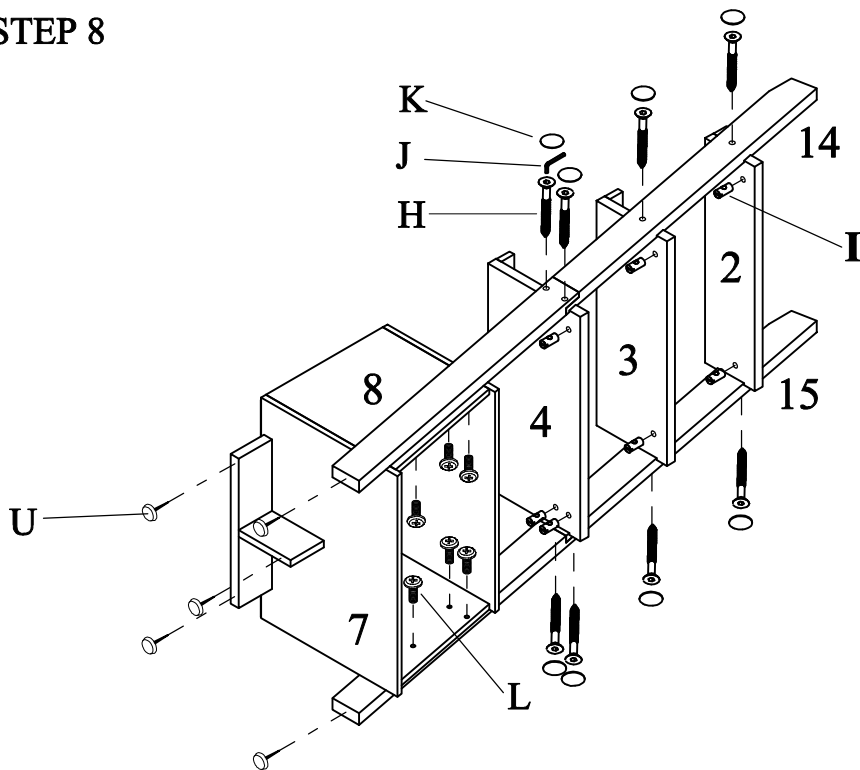

ÉTAPE / STEP 9

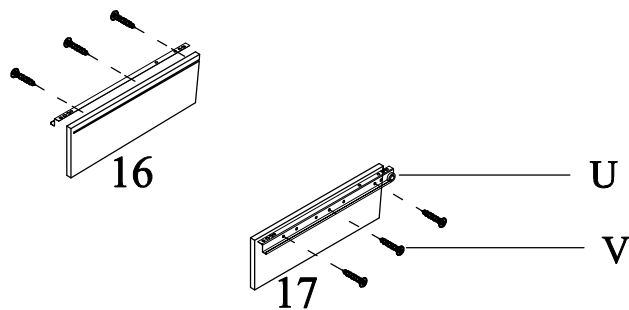

2562 2755

ÉTAPE / STEP 10

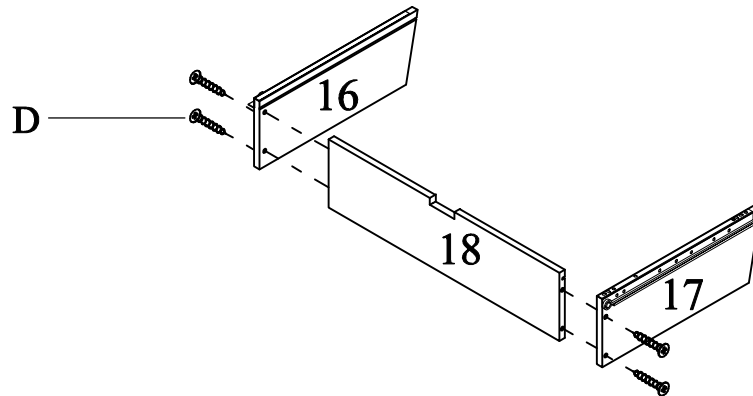

ÉTAPE / STEP 11

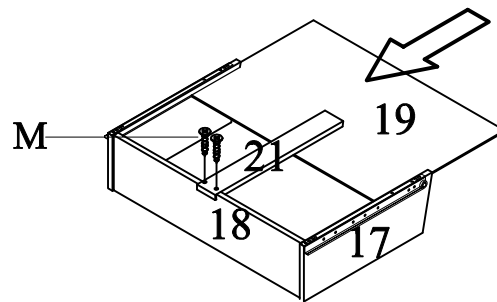

ÉTAPE / STEP 12

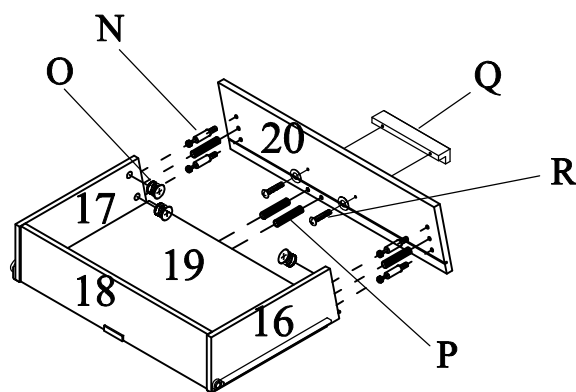

ANTI-TIPPING STRAP INSTRUCTION

HARDWARE (INCLUDED) :

TOOLS NEEDED (NOT INCLUDED) :

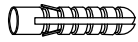

DRYWALL ANCHOR ϕ 8X40 X 1PC



DRILL & DRILL BIT

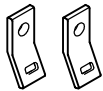

METAL BRACKETS 12×12×1 X 2PCS



LIGHT HAMMER

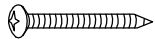

DRYWALL SCREW ϕ 5X40 X 1PC



STRAP 197×5×1 X 1PC



FLATHEAD SCREW ϕ 4X25 X 1PC

Note: Hardware included only compatible with standard drywalls.

STEP 1 / ETAPE 1

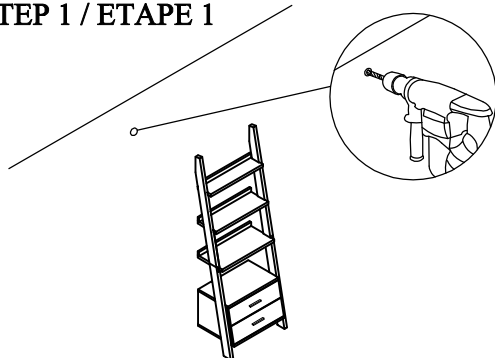

1. Find spot on wall 1" below top of item.
2. Using a drill bit slightly thinner than anchor, drill hole into drywall.

STEP 2 / ETAPE 2

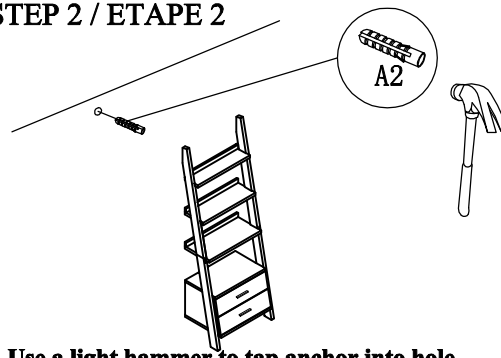

1. Use a light hammer to tap anchor into hole.
2. Anchor should fit snugly. If hole is too small, drill again to increase hole size. Do not force anchor into wall.

STEP 3 / ETAPE 3

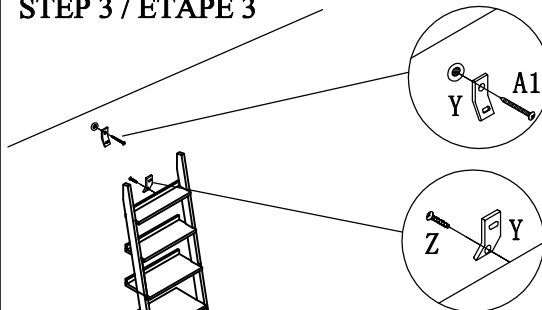

1. Insert dry wall screw into metal bracket and into drywall anchor.
2. Insert flathead screw into second metal bracket and into back of item along top edge.

STEP 4 / ETAPE 4

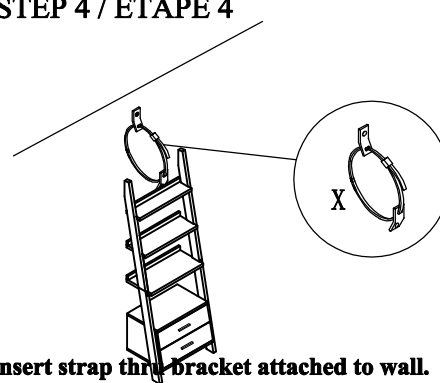

1. Insert strap thru bracket attached to wall, then thru bracket on item, and into head of strap.
 2. pull lightly til strap stops.
- Assembly is complete.