

Assembly Instructions

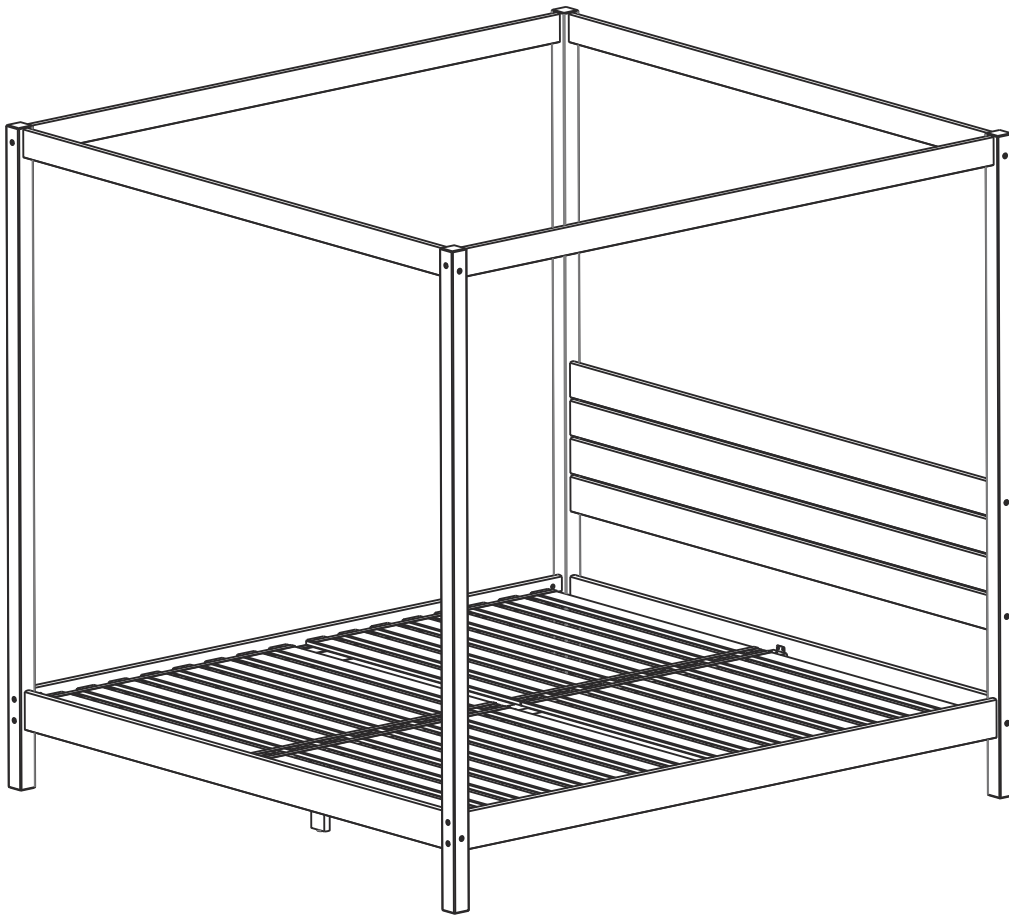

General assembly guidelines

- I. Ensure that all parts and hardware are available before beginning assembly.
- II. Follow each step carefully to ensure the proper assembly of this product.
- III. Two people are recommended for ease in the assembly of this product.
- IV. The three main types of hardware used to assemble this product are wood dowels, screws and bolts.
- V. A hammer, Phillips head and Slotted head screwdrivers are required for the assembly of this product.

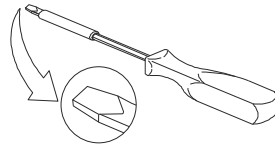
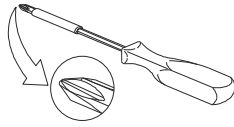
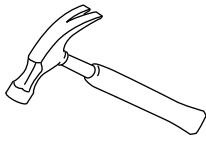

- VI. Power tools should not be used to assemble this product.

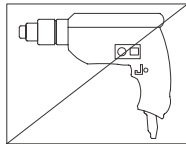



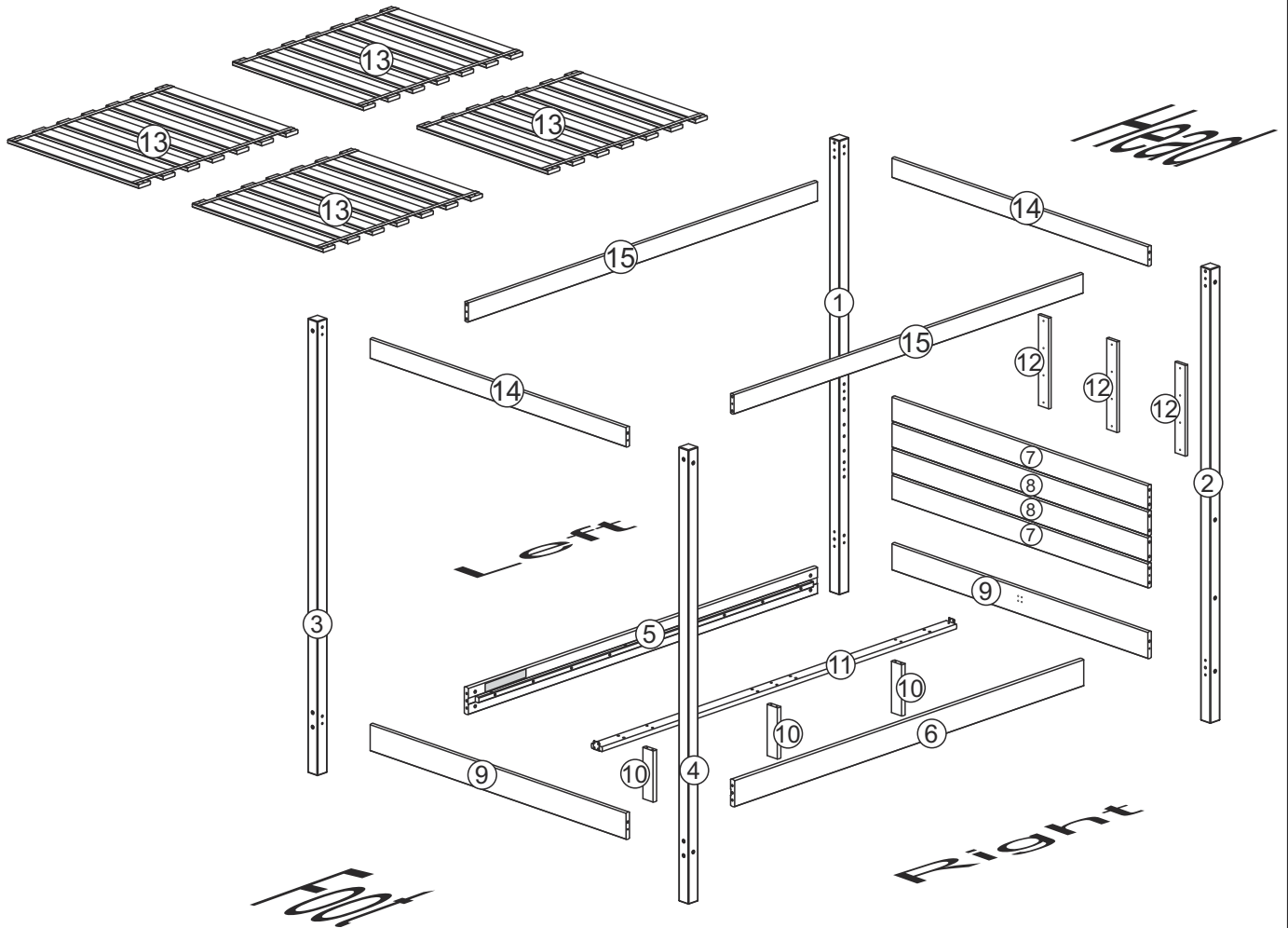





Parts List

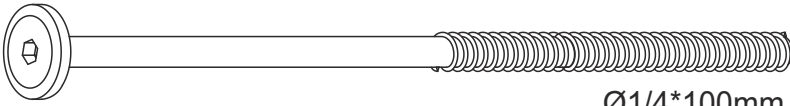

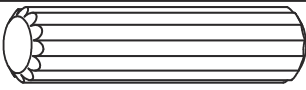
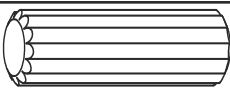
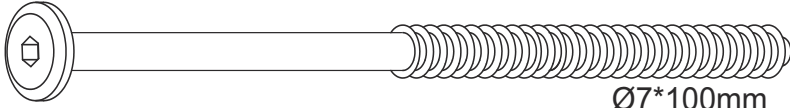
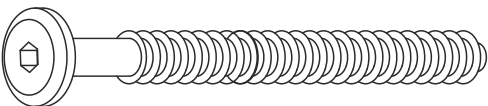
Part#	Description	Qty
1	Headboard Left Post	1
2	Headboard Right Post	1
3	Footboard Left Post	1
4	Footboard Right Post	1
5	Left side rail	1
6	Right Side Rail	1
7	Upper Rail / Lower Slat(HEADBOARD)	2
8	Middle Slat (HEADBOARD)	2
9	Head/Foot Rail	2

Part#	Description	Qty
10	Central Foot	3
11	Central Support	1
12	Union Support	3
13	Set Slat	4
14	Upper Short Slat	2
15	Upper Long Slat	2

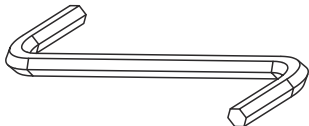
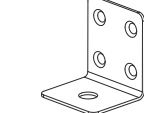
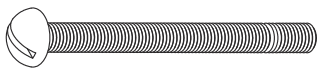
Hardware List

A	 Ø1/4*100mm	Bolt (Head 13)	08 pcs	
B		1/4mm	Barrel nut	08 pcs
C		Ø10*40mm	Wooden dowel	36 pcs
D		Ø10*30mm	Wooden dowel	16 pcs
E	 Ø7*100mm	Bolt (Head 13)	16 pcs	
F	 Ø7*60mm	Bolt (Head 13)	06 pcs	
G		Ø4*35mm	Screw	16 pcs
H		Ø4*25mm	Screw	12 pcs
I		Ø3,5*16mm	Screw	08 pcs
J			Hex Key	01 pcs
K			Corner Brace	02 pcs
L		Ø3/16*1 1/2	Screw	02 pcs
M		Ø3/16	Nut	02 pcs
N		Ø3/16	Washer	02 pcs

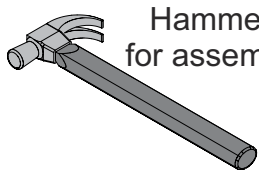

Hammer recommended for assembly (not included)

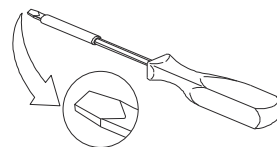
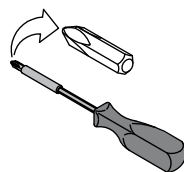

Phillips head and slotted head screwdrivers are required for assembly (not included)

The hardware quantities listed above are required for proper assembly. Some extra hardware may also have been included.

Step 1

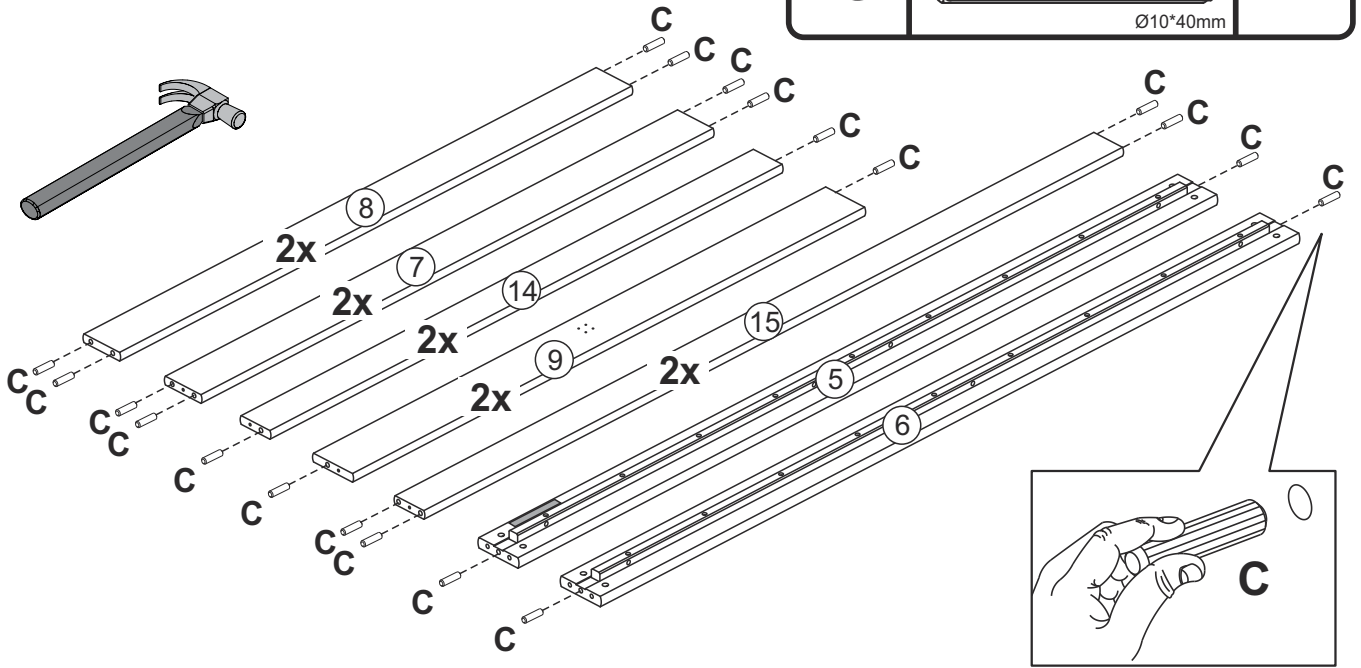
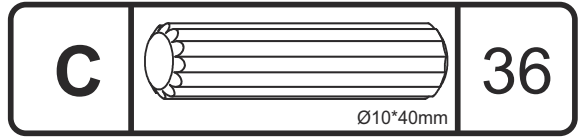

Insert wood dowel (C) into parts (5,6,7,8,9,14 and (15).

Step 2

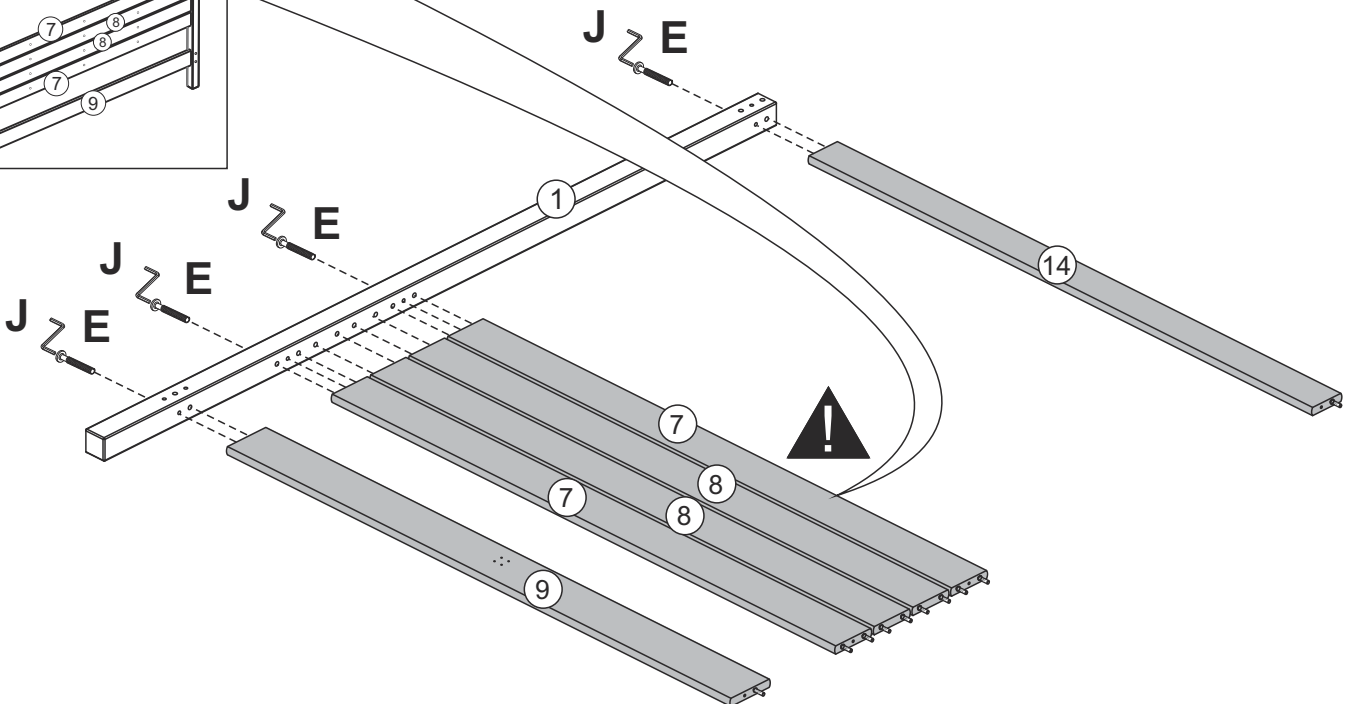
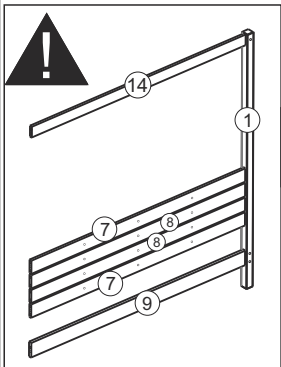
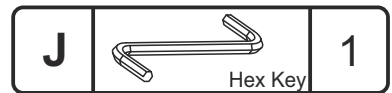
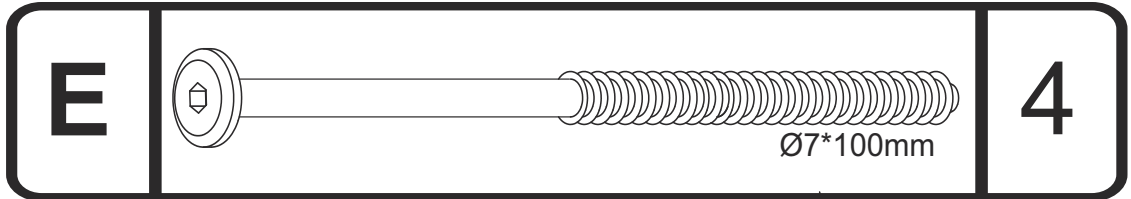

HEADBOARD

Secure part 1 to parts 7, 9 and 14 with screw (E) using Hex Key (J).
Align dowels in part 8 to holes in part 1.

Step 3

E

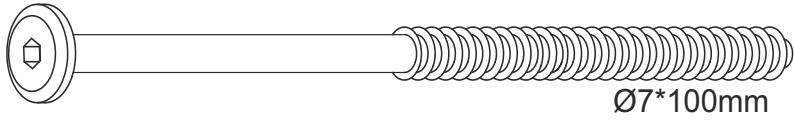

4

J

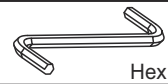

1

Hex Key

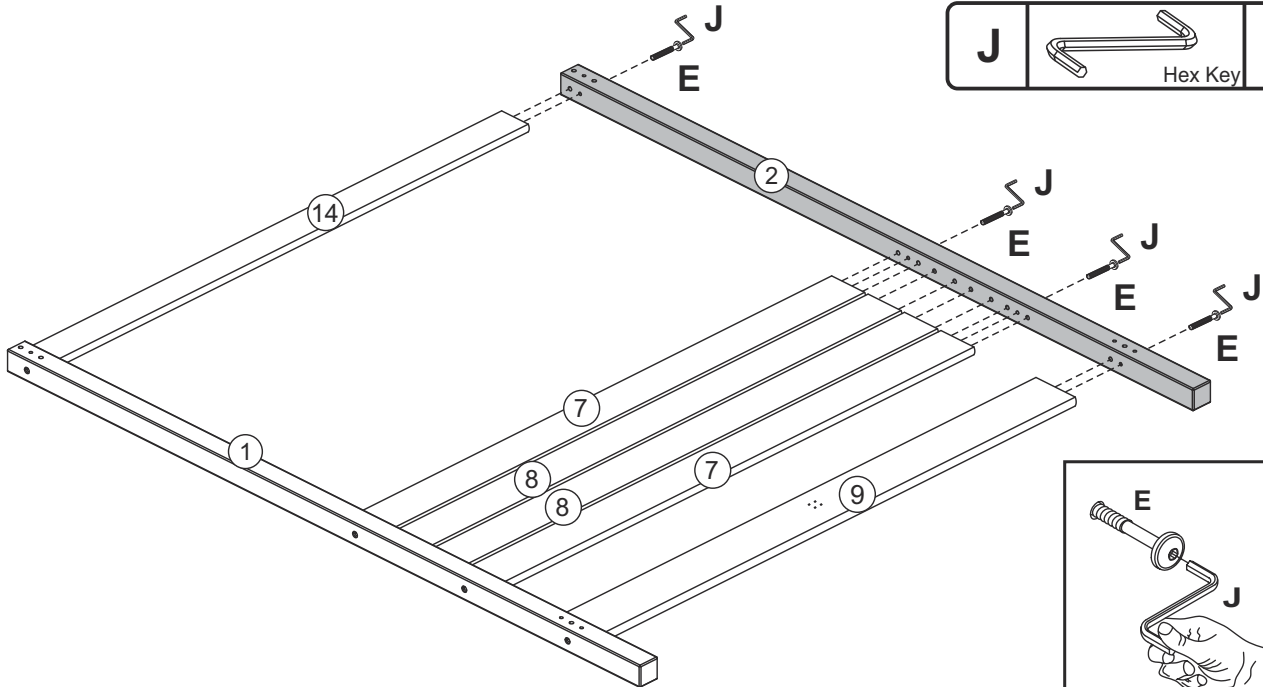

Secure part 2 to parts 7,9 and 14 with screw (E) using Hex Key (J).
Align dowels in part 8 to holes in part 2.

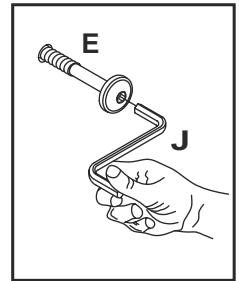

Step 4

H



12

Pre Drilled Holes

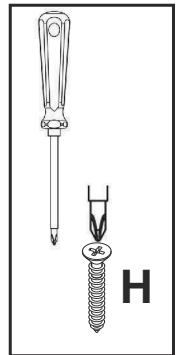
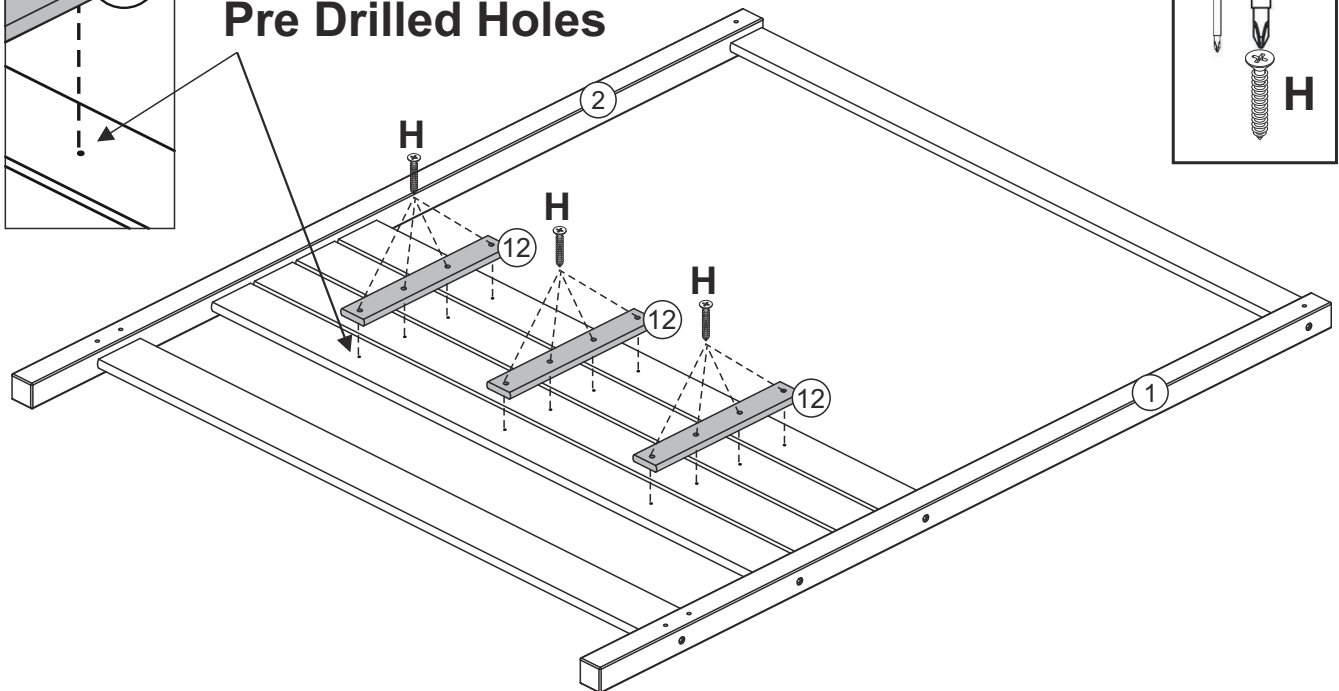
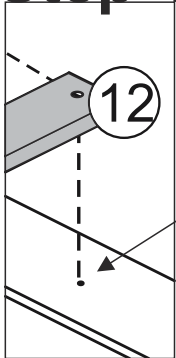

HEADBOARD

Secure part 12 to headboard with screw (H) using phillips head screwdriver.

Step 5

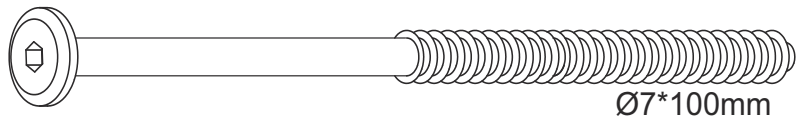
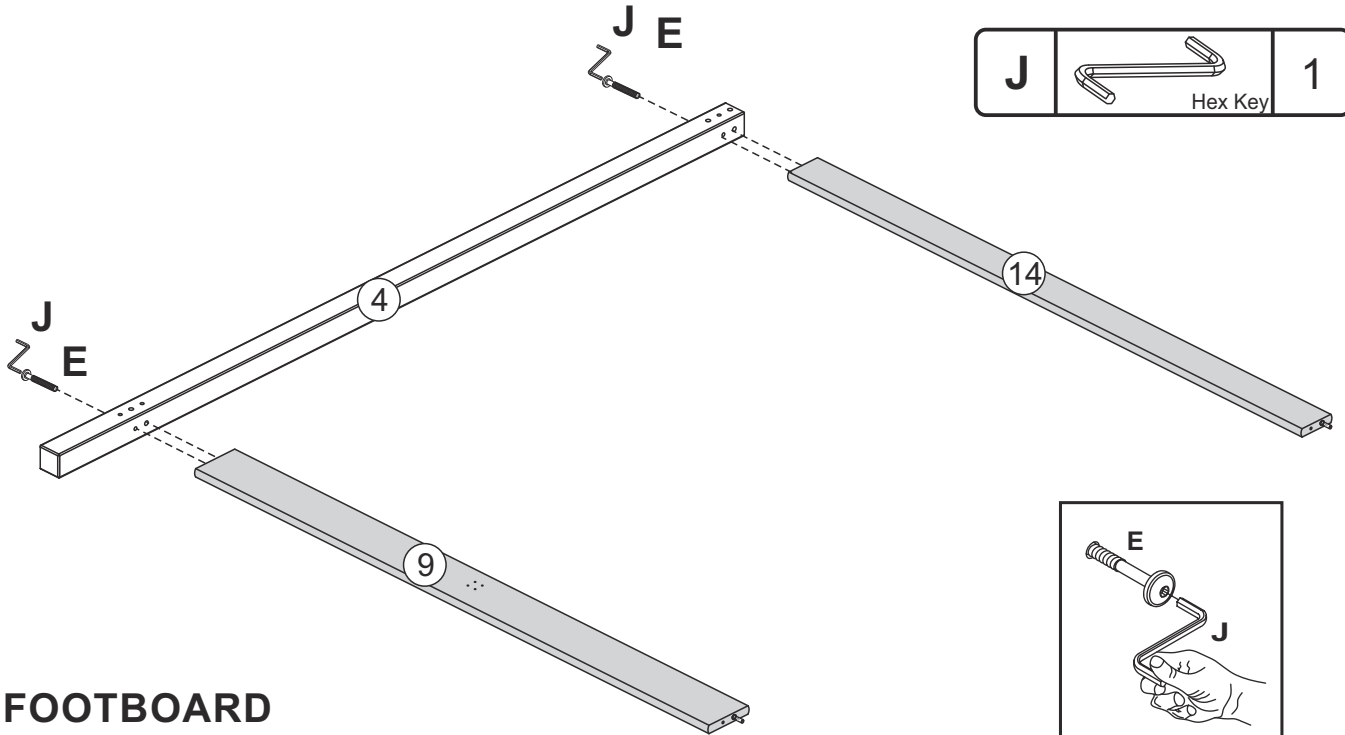
E**2****J**

Hex Key

1

FOOTBOARD

Secure part 4 to parts 9 and 14 with screw (E) using Hex Key (J).

Step 6

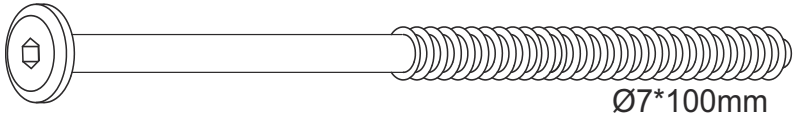
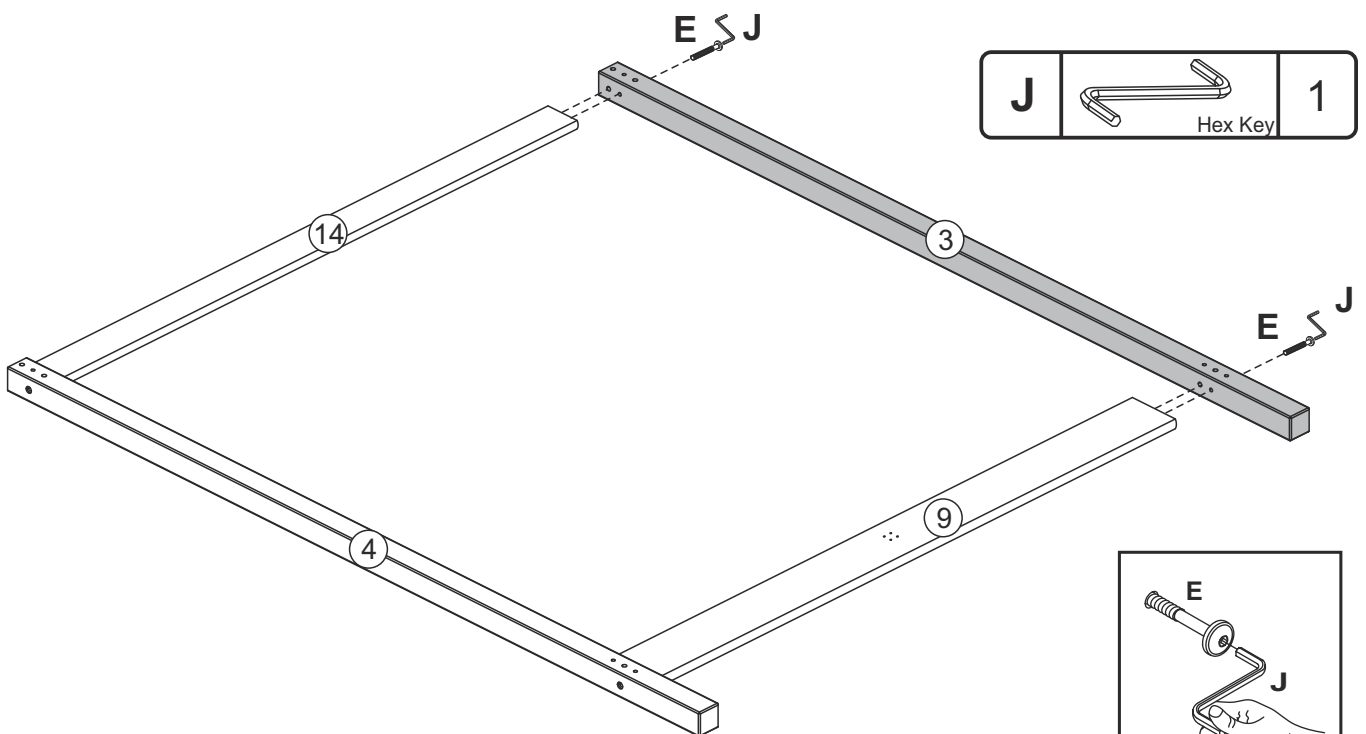
E**2****J**

Hex Key

1

FOOTBOARD

Secure part 3 to parts 9 and 14 with screw (E) using Hex Key (J).

Step 7

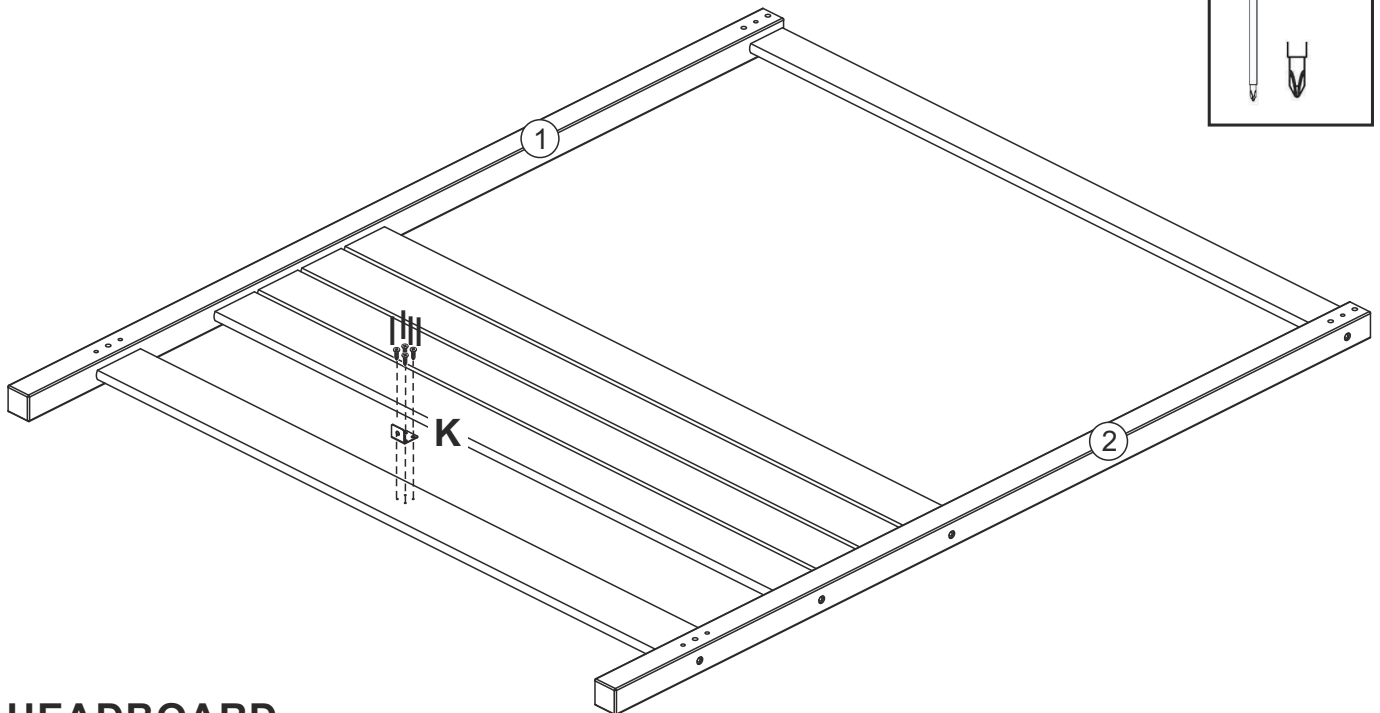
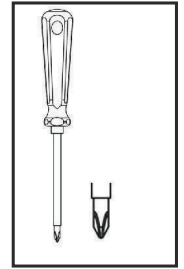

HEADBOARD

Secure hardware (K) to headboard with screw (I) using phillips head screwdriver.

Step 8

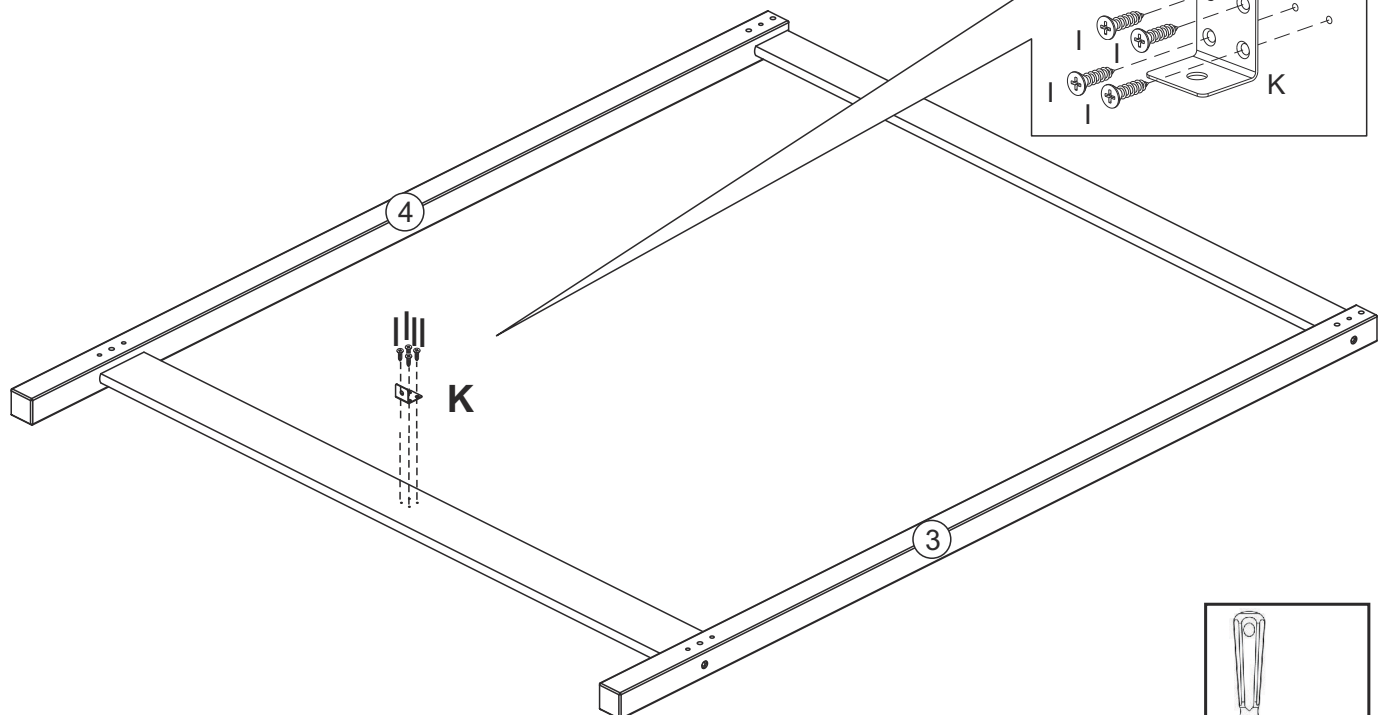
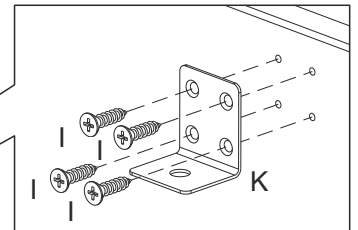

FOOTBOARD

Secure hardware (K) to footboard with screw (I) using phillips head screwdriver.

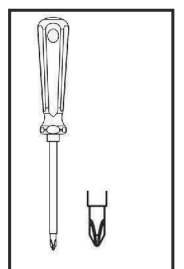

Step 9

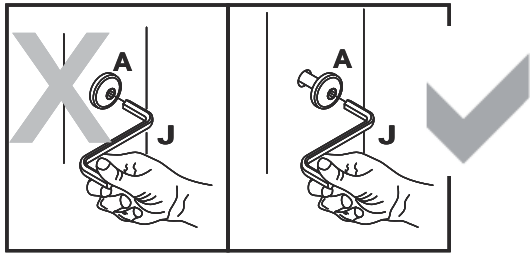

In this step, please do not tighten the screw all the way.

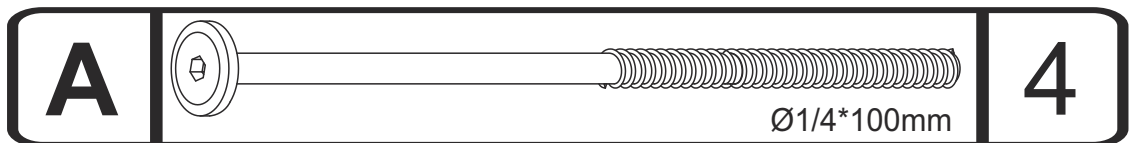
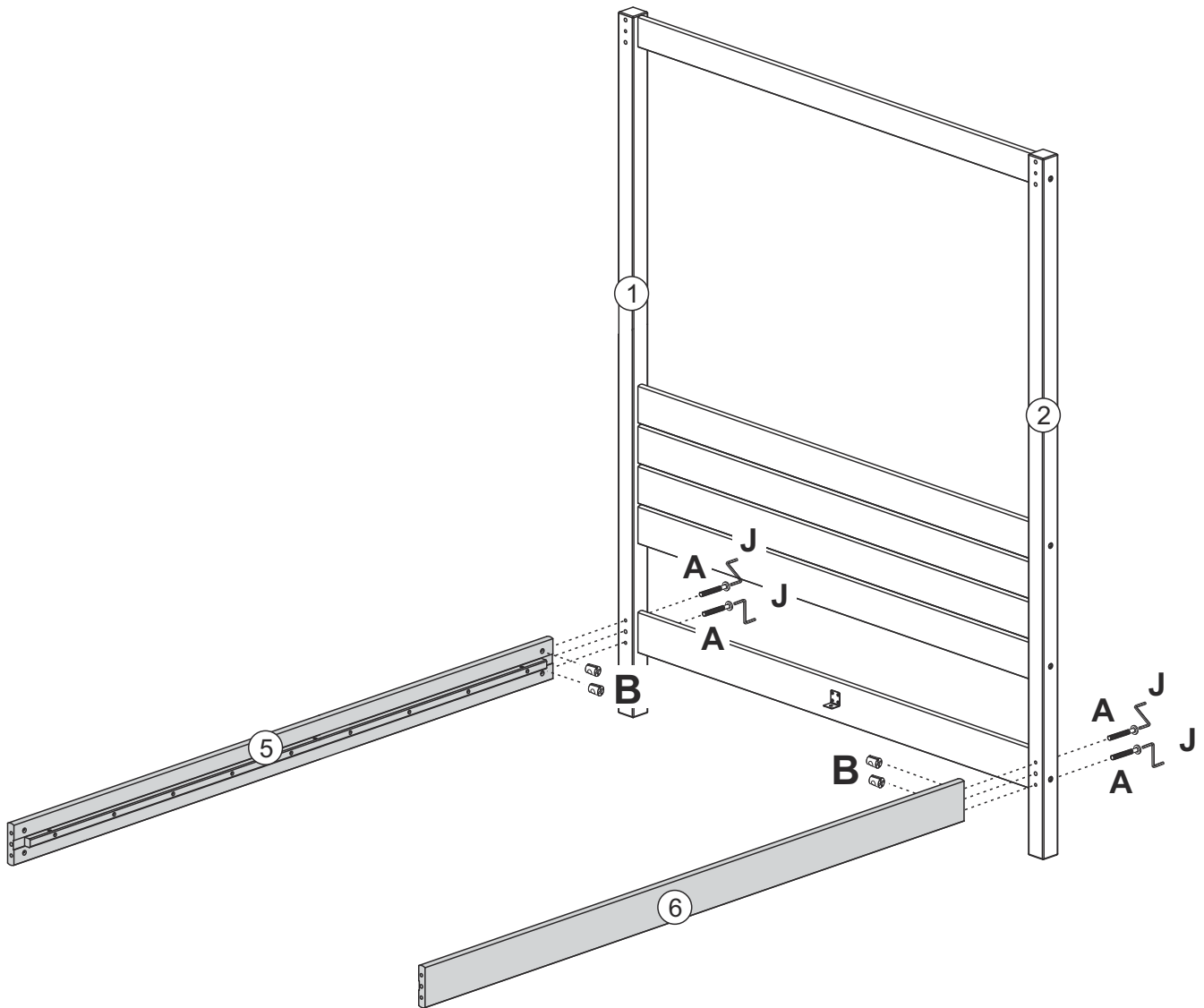

HEADBOARD



Secure parts 5 and 6 to headboard with screw (A) and barrel nut (B) using Hex Key (J).

Step 10

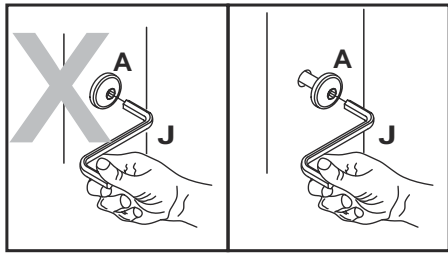

In this step, please do not tighten the screw all the way.

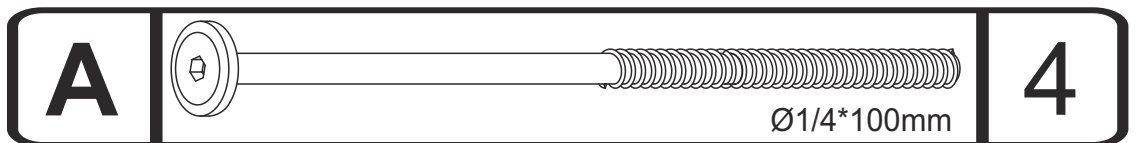
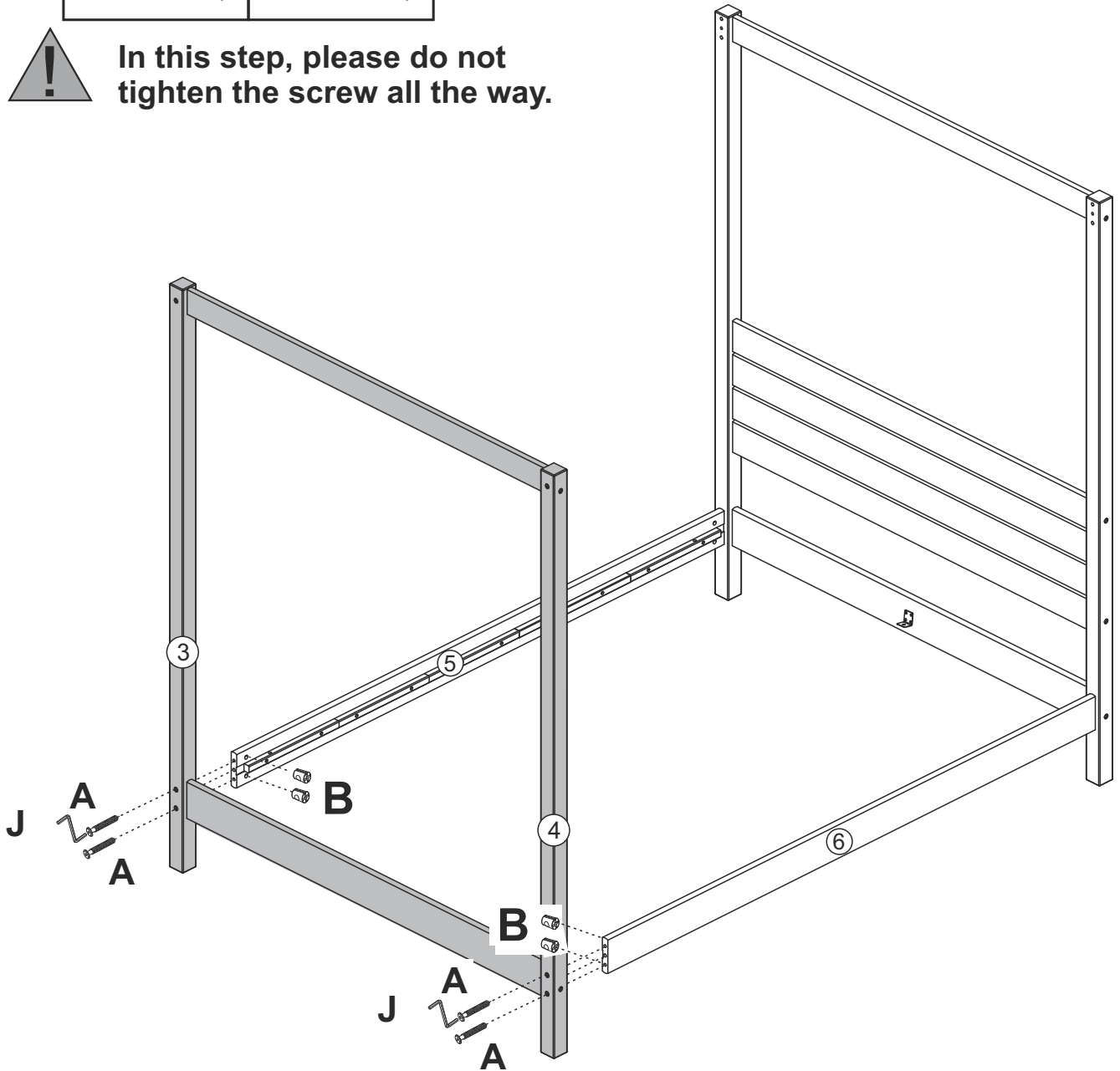

FOOTBOARD

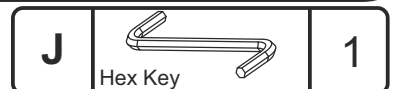
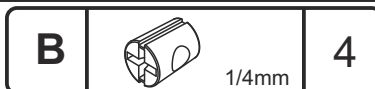

Secure part 5 and 6 to Footboard Post (3) and (4) and Barrel nut (B) using hex key.

Step 11

E

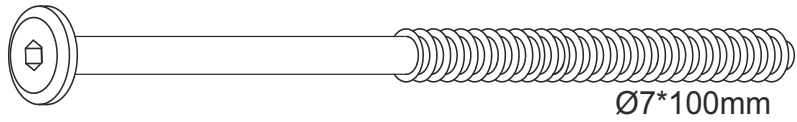

4

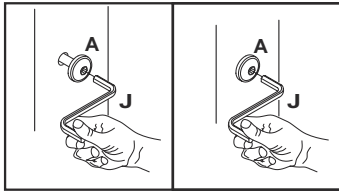
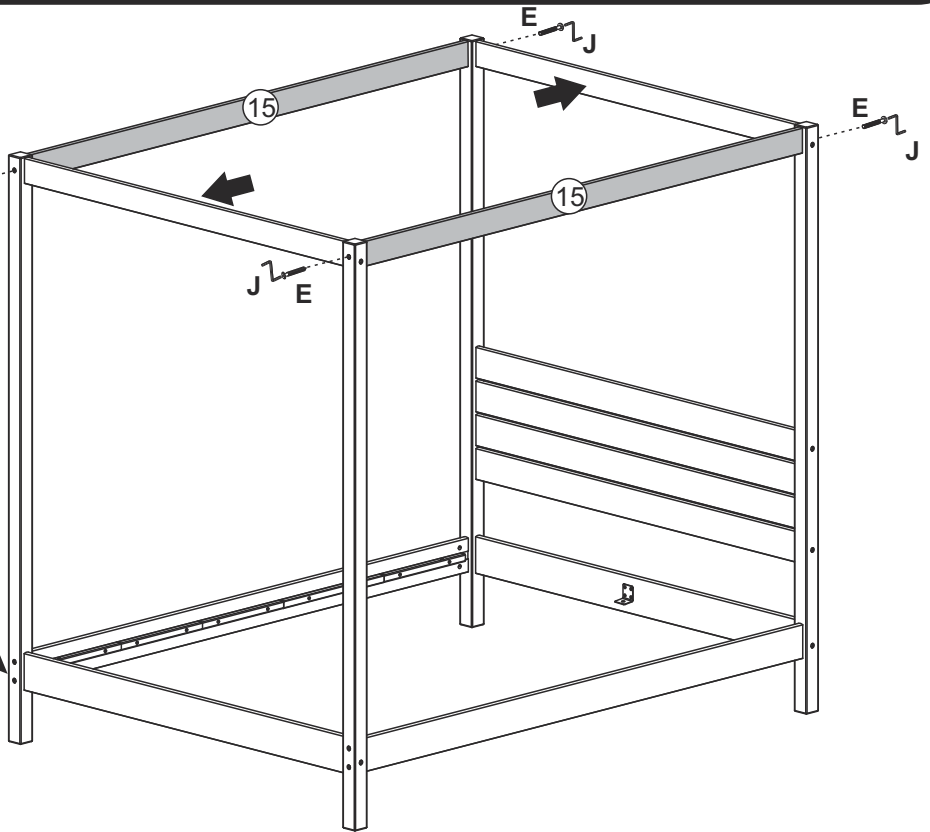
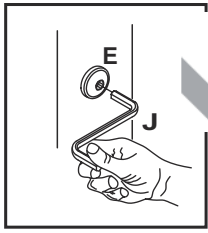

! Finish tightening the screws from steps 9 and 10.

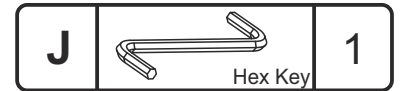

Secure part 15 with screw (E) using Hex Key (J).

Step 12

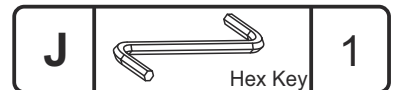
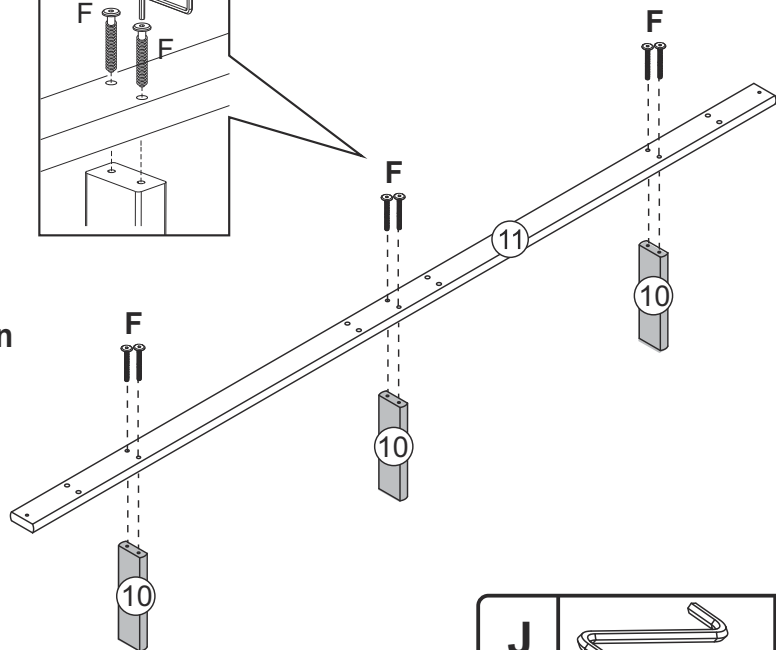
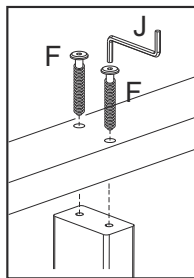
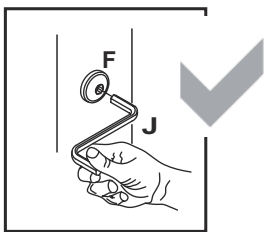

! In this step please tighten all screws to the end.

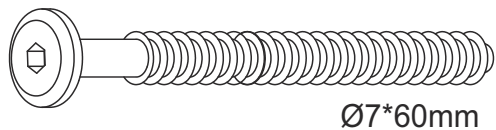

Secure part 11 to parts 10 with screw (F) using Hex Key (J).

F



6

Step 13

L		2	M		2	N		2
	Ø3/16*1 1/2			3/16			3/16	

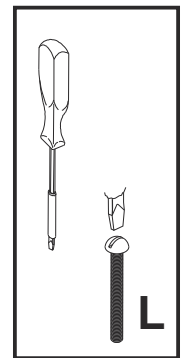
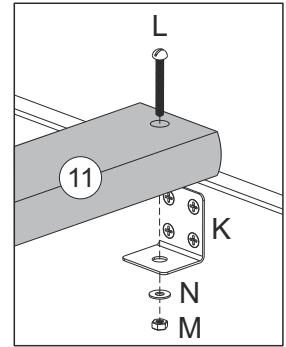
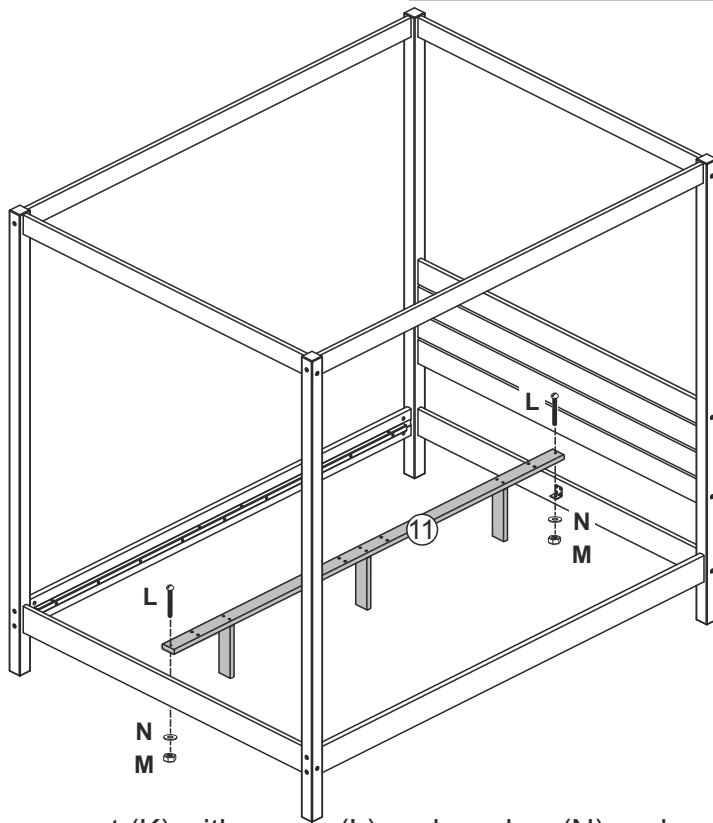

Secure part 11 to support (K) with screw (L) and washer (N) and nut (M) using slotted head screwdriver.

Step 14

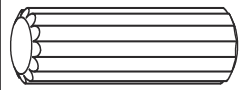
D		16
	Ø10*30mm	

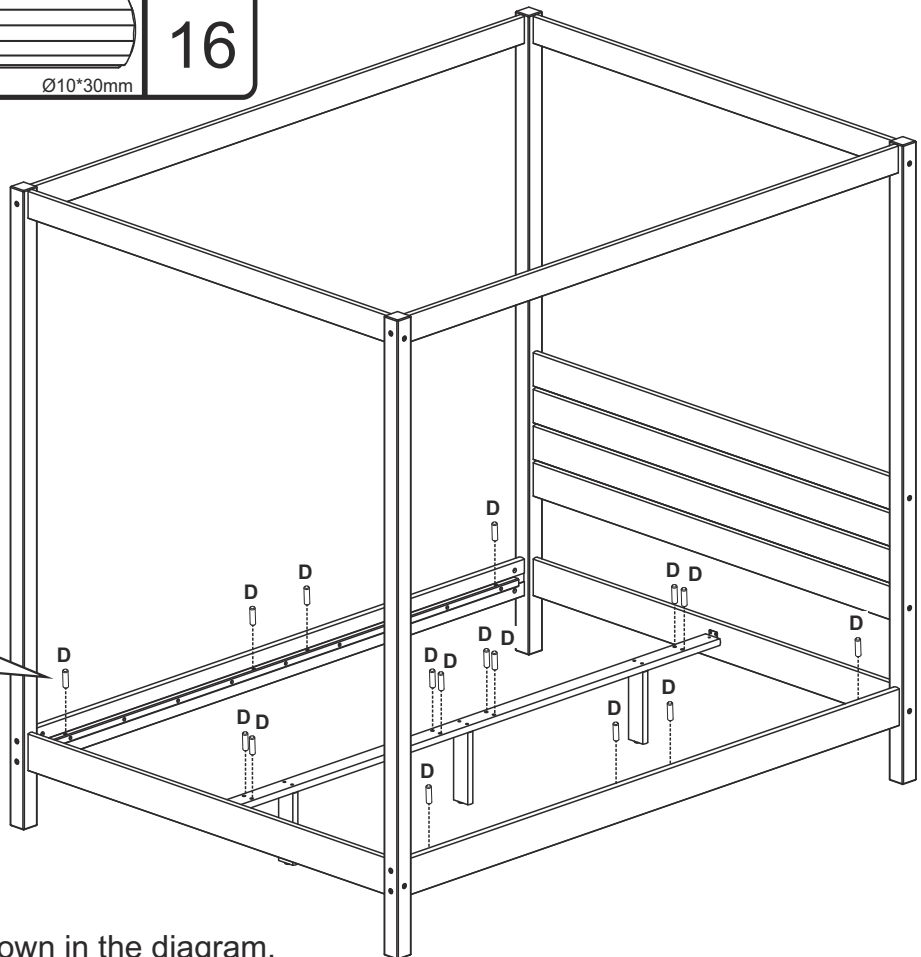
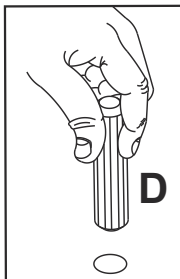
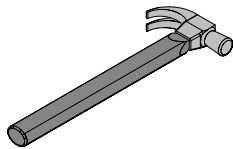

Insert wooden dowel (D) as shown in the diagram.

Step 15

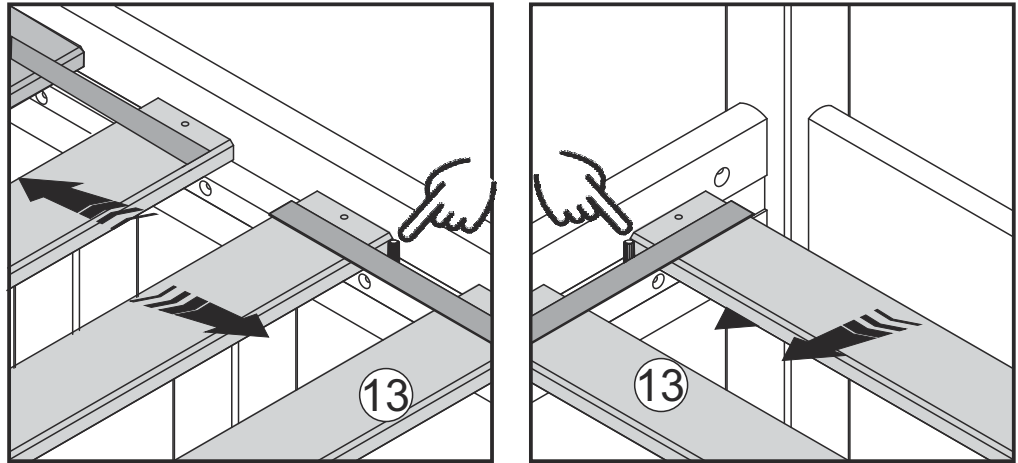

In this step, distribute sets of slats 13 using the applied dowels as guides.

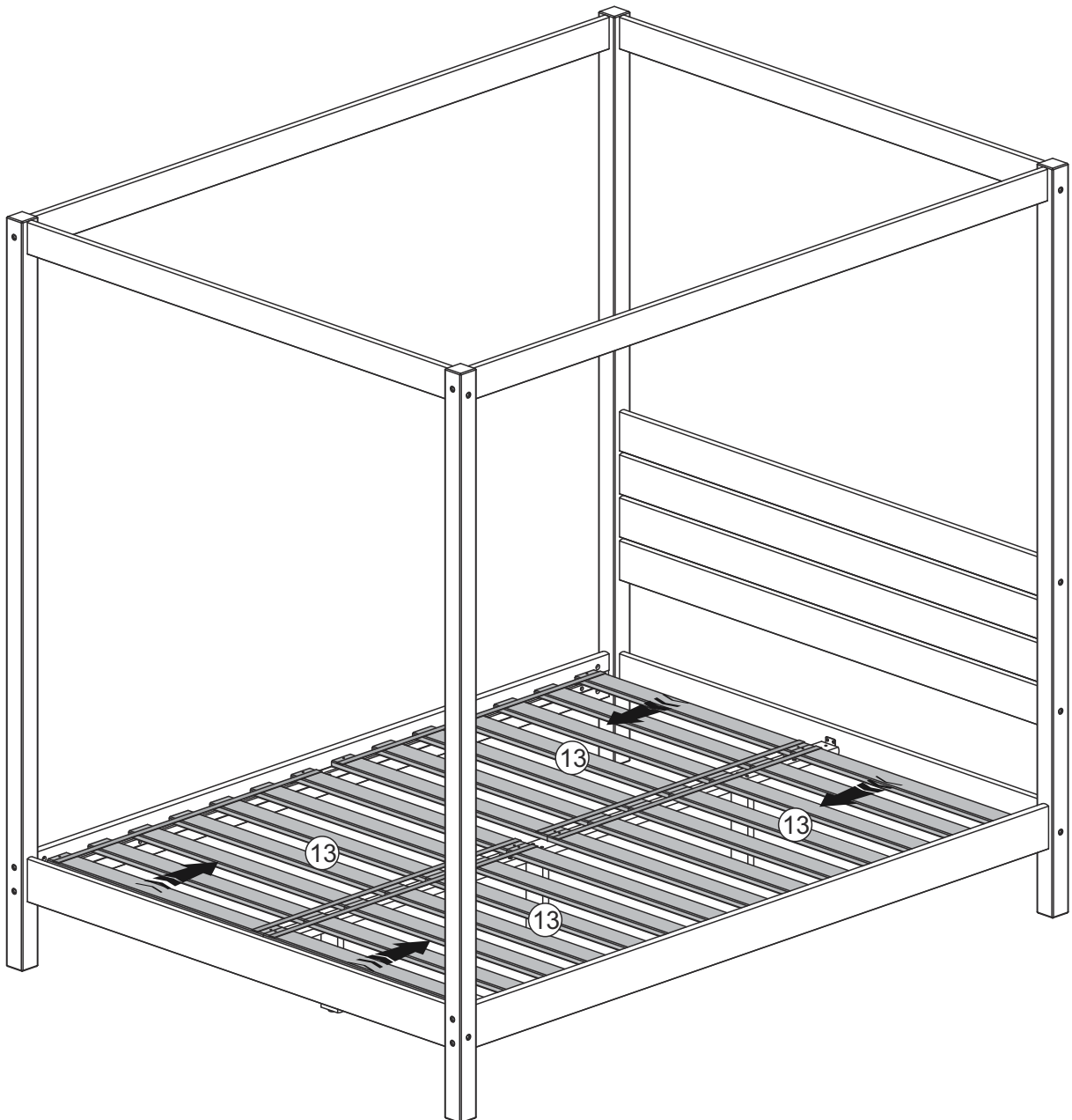

Insert the set of slats 13 as shown in the diagram.

Step 16

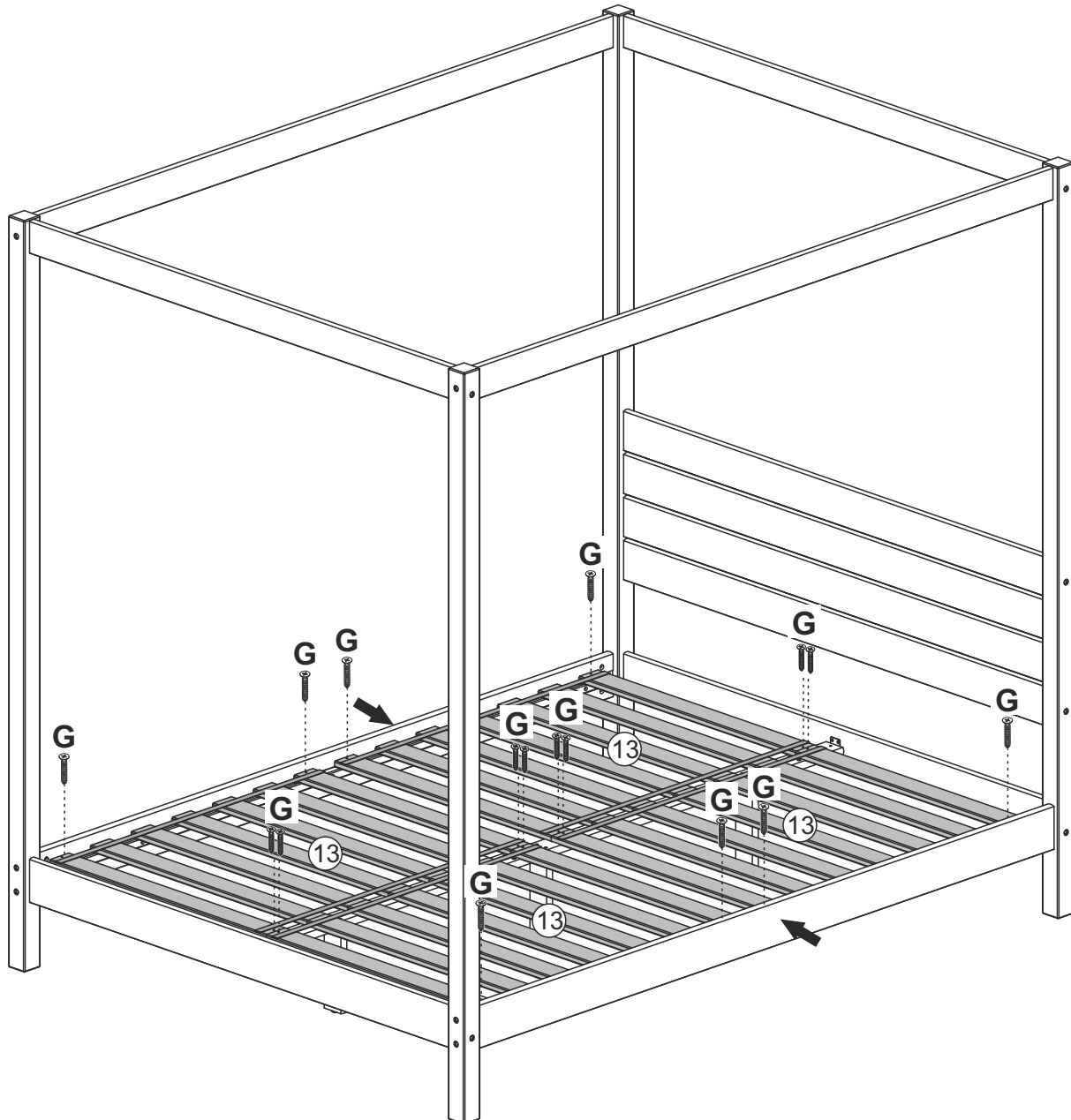
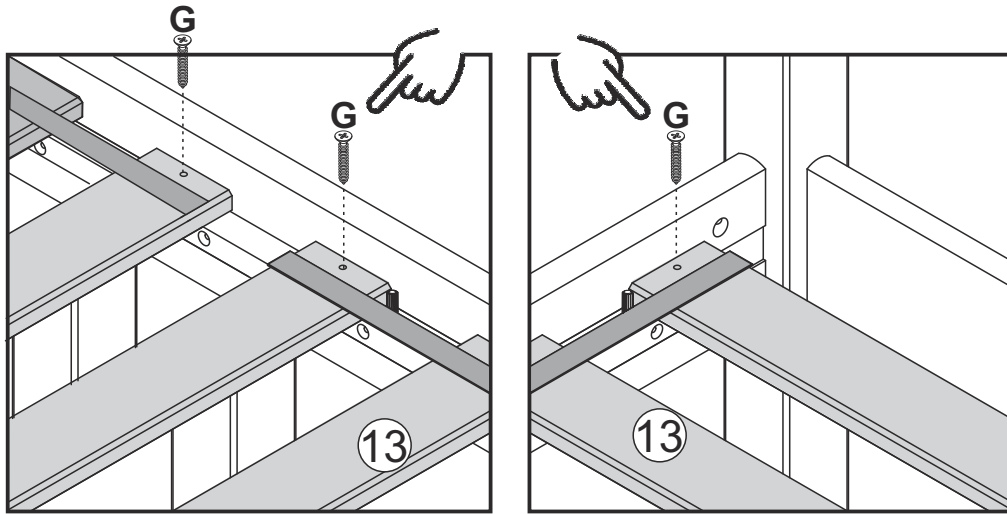
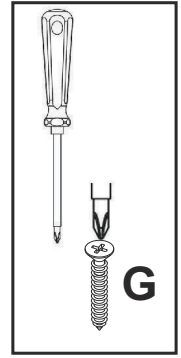
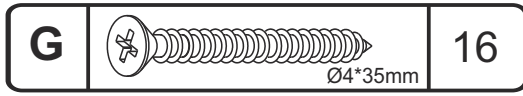

Secure the set of slats 18 with screw (G) using phillips head screwdriver.

Step 17

