

# ASSEMBLY INSTRUCTION

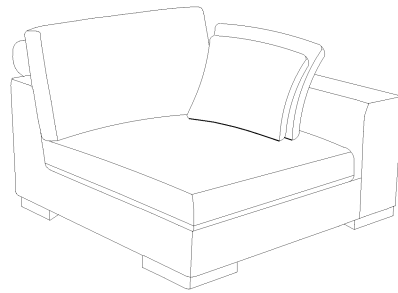

## PARTS LIST

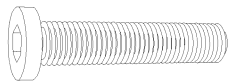
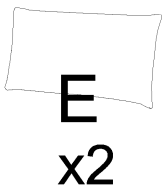
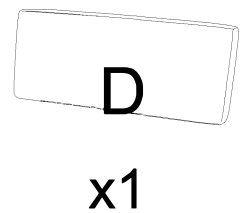
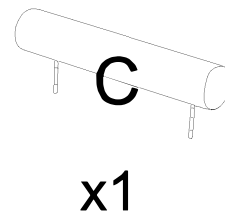
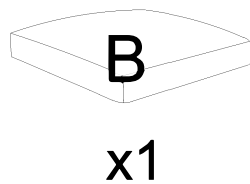
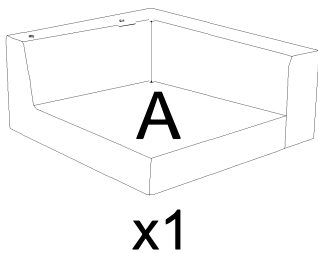

5/16\*6.5CM

**1** x8



5/16\*19MM

**2** x8



M5/40\*100MM

**3** x1

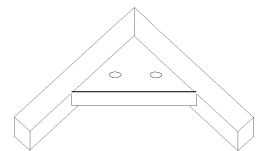

**4** x4

## ASSEMBLY INSTRUCTION

### Step1

Open up Velcro of Non-woven Fabric cover on the bottom to remove hardware legs and parts°

1、 After removing the cushion from the compress bag, please allow air to flow through the cushion for few days. You can try to fluff cushion by push in and push out on all four sides of the cushion. Hitting the top/front of the cushion with your hand to fluff them after installation.

2、 Please allow at least 24 hours for the cushions to recover to its natural state after removing from the package.

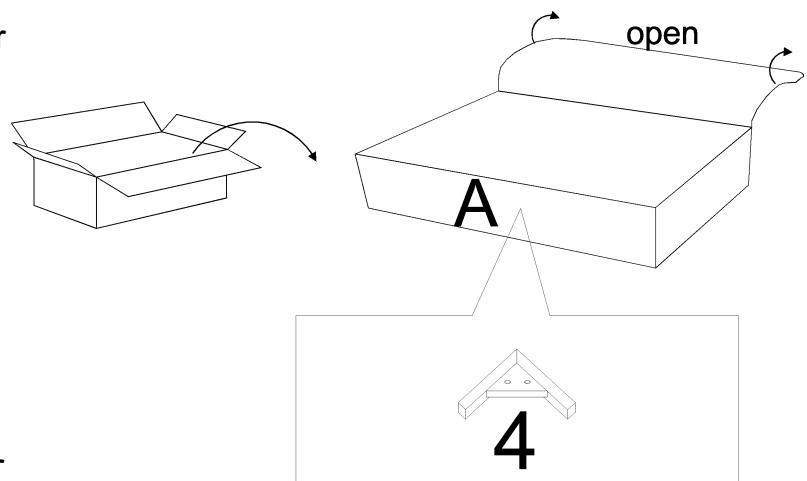

Step2

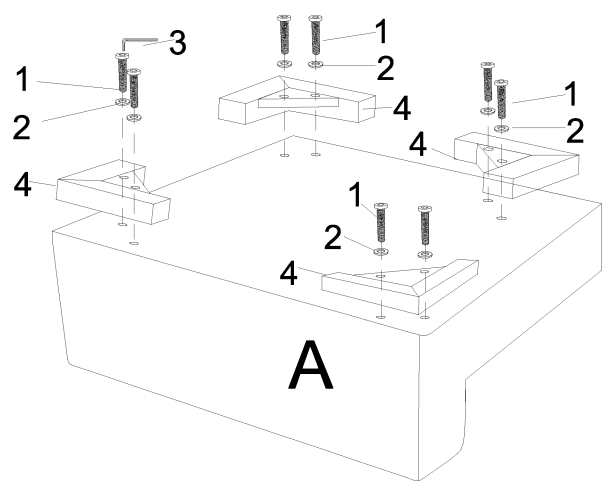

Step3

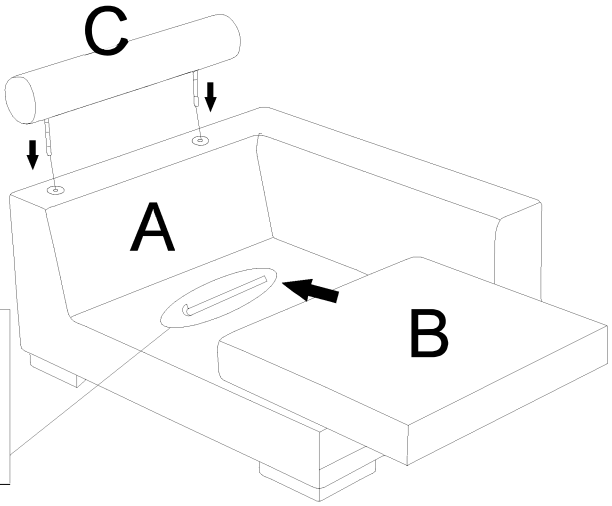

Please kindly remove the black cover tape from the velcro before you place the cushion on top.

Step4

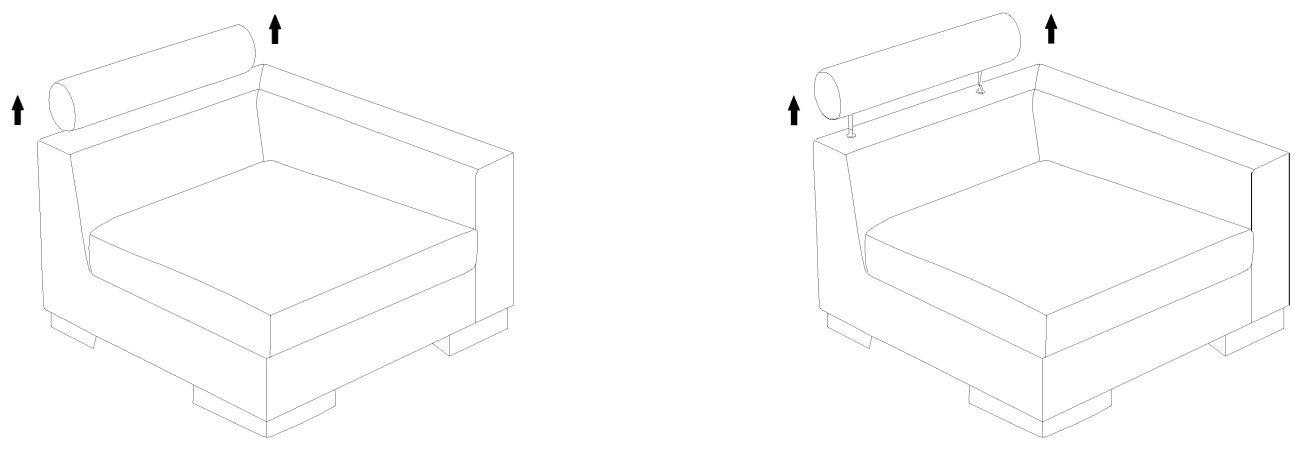

Step5

