

Modern Extendable TV Stand

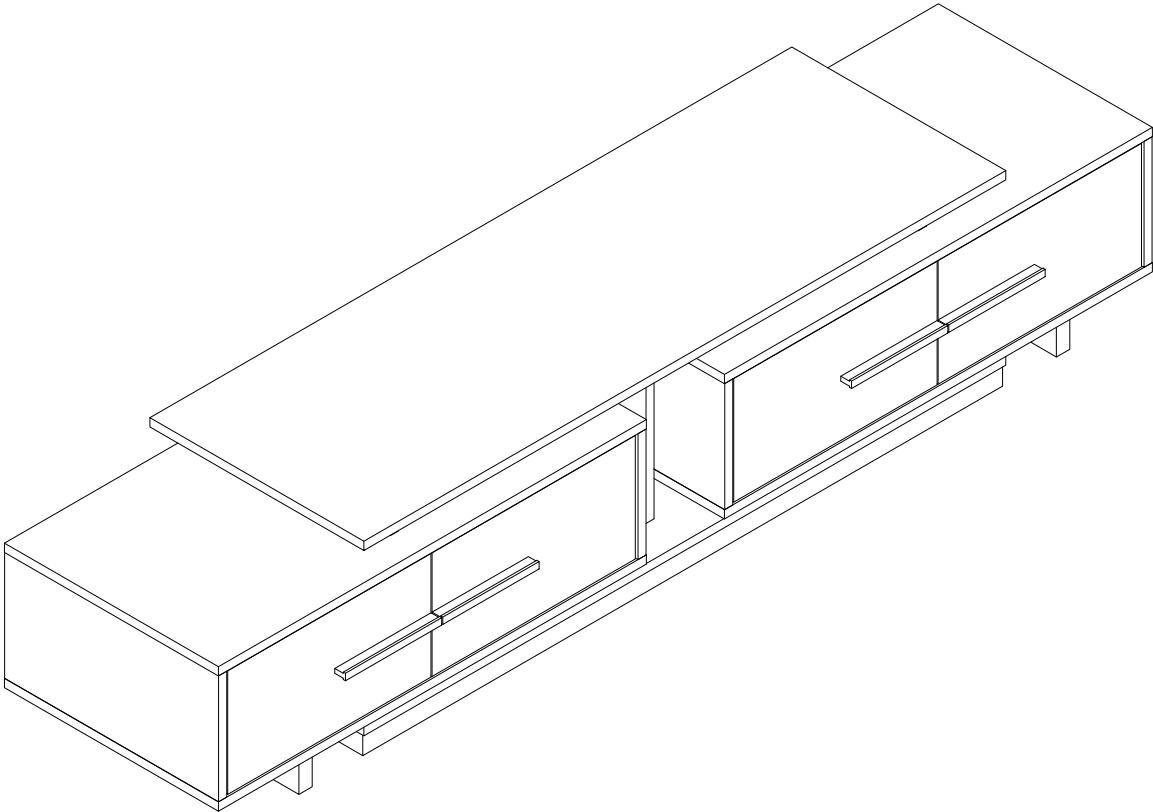

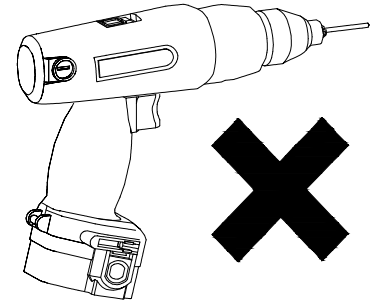
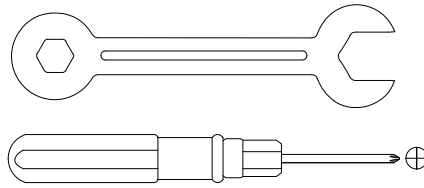
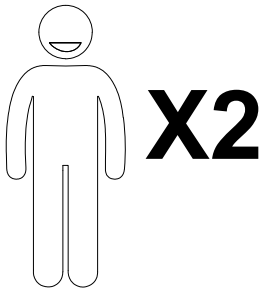
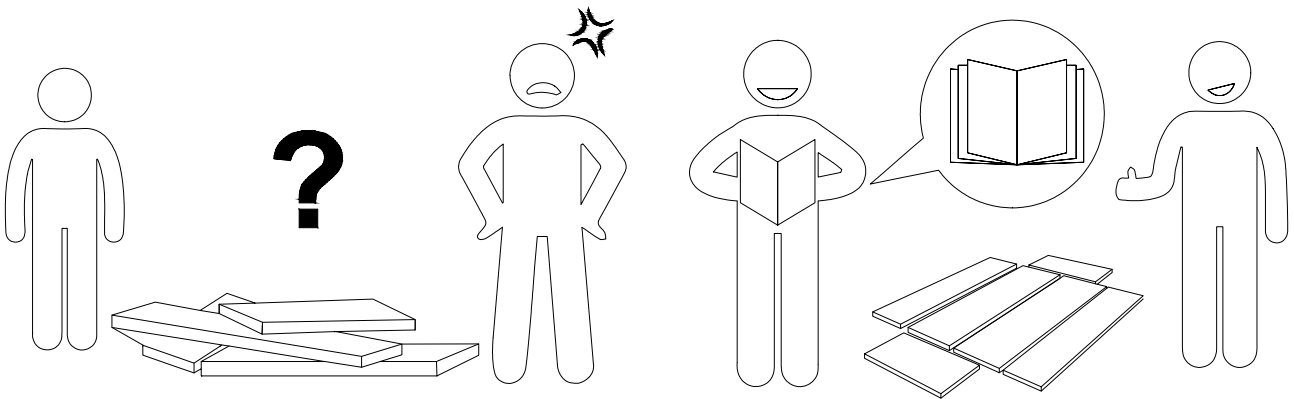

We recommend using hand tools for assembly.

If an electric screwdriver is used, reduce power and torque to avoid damage to the product.



Warm Tips

1. Carefully read these instructions and keep them for future reference.
2. Check the parts list and confirm everything's there before starting assembly.
3. When assembling, put all parts on a soft, smooth surface like a carpet to avoid scratches.
4. Don't fully tighten screws until all parts are confirmed in place to avoid misalignment.

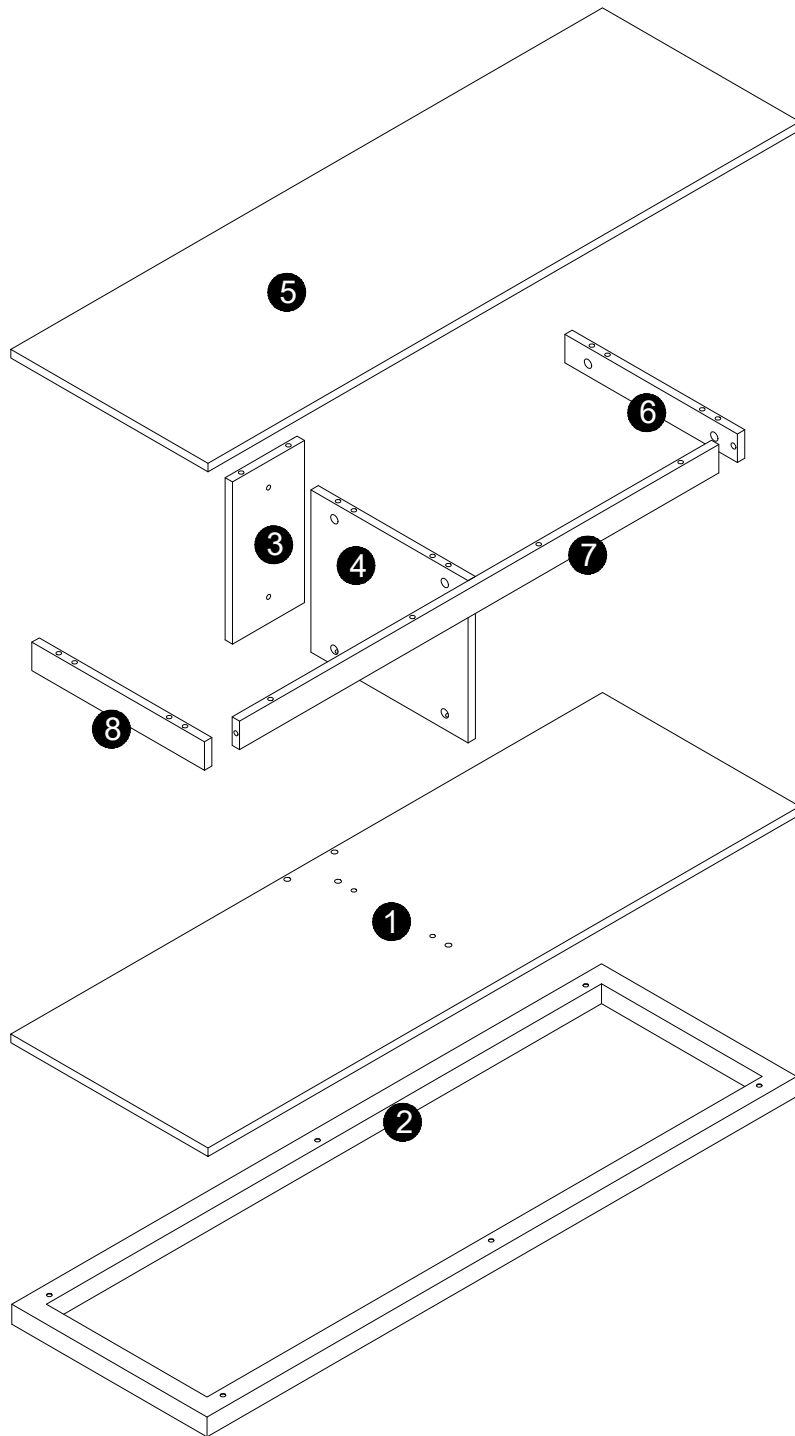

⚠ Caution

Make sure all parts are included. Most board parts are labeled or stamped on the raw edge. Contact us for a free replacement if you encounter any damaged or missing parts.

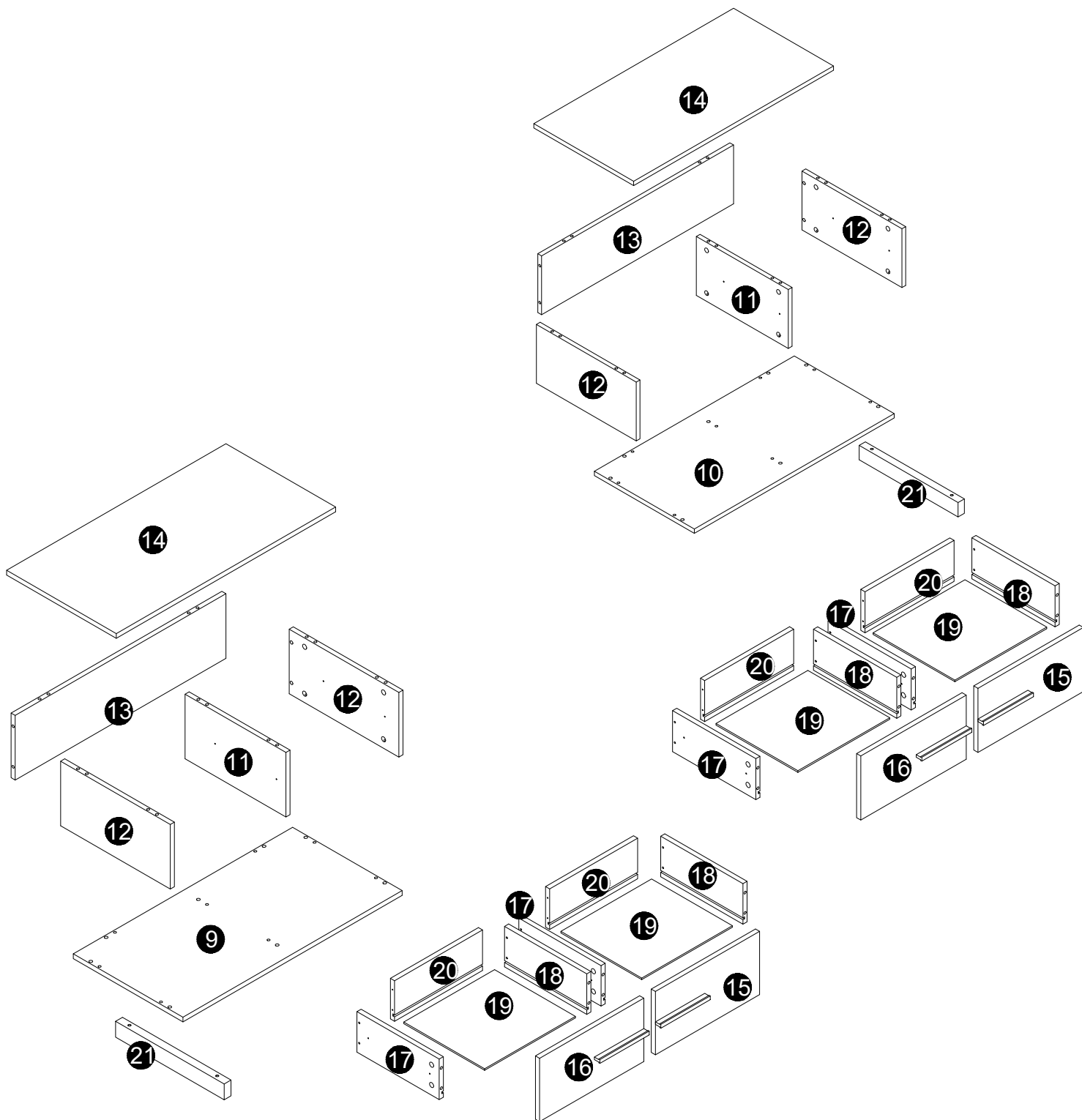







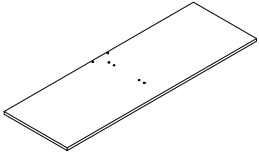
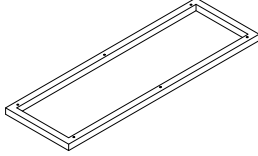
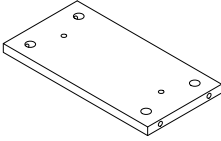
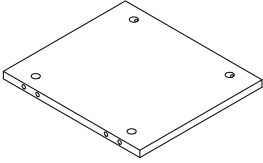
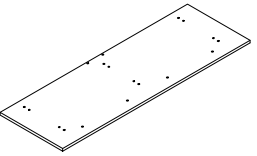
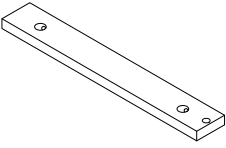
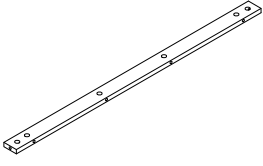
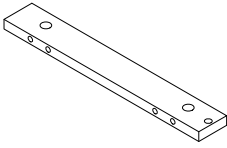
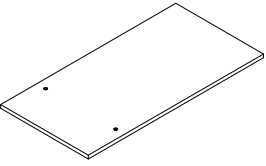
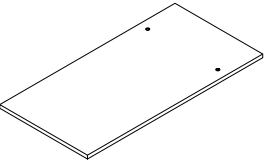
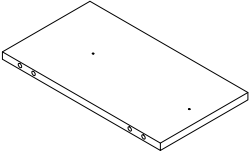
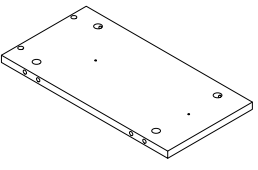
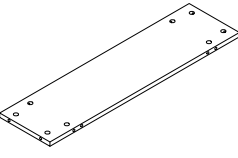
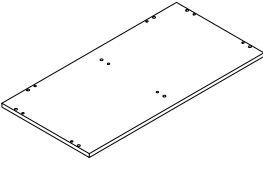
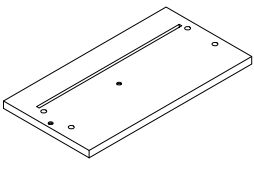
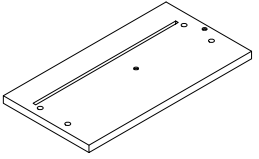
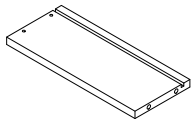
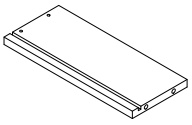
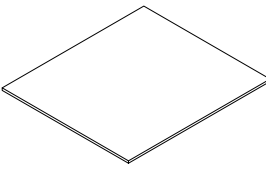
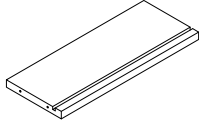
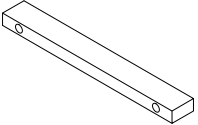

⚠ Caution

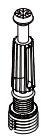
Make sure all parts are included. Most board parts are labeled or stamped on the raw edge. Contact us for a free replacement if you encounter any damaged or missing parts.

Parts List

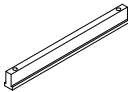
<p>1</p> 	<p>2</p> 	<p>3</p> 	<p>4</p> 	<p>5</p> 
1 pc	1 pc	1 pc	1 pc	1 pc
<p>6</p> 	<p>7</p> 	<p>8</p> 	<p>9</p> 	<p>10</p> 
1 pc	1 pc	1 pc	1 pc	1 pc
<p>11</p> 	<p>12</p> 	<p>13</p> 	<p>14</p> 	<p>15</p> 
2 pcs	4 pcs	2 pcs	2 pcs	2 pcs
<p>16</p> 	<p>17</p> 	<p>18</p> 	<p>19</p> 	<p>20</p> 
2 pcs	4 pcs	4 pcs	4 pcs	4 pcs
<p>21</p> 				
2 pcs				

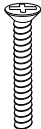
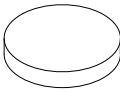
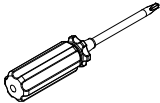
Hardware List

A	B	C	D	E	F
 M6x35mm	 Ø15x12mm	 Ø8x30mm	 Ø6x12mm	 Ø3.5x14mm	
74 pcs	74 pcs	40 pcs	10 pcs	32 pcs	4 pcs
G	H	I	J	K	L
 Ø4x16mm	 300mm	 Ø7x38mm		 Screwdriver	 Ø3.5x35mm
8 pcs	4 pcs	2 pcs	10 pcs	1 pc	16 pcs

Installation of Cams and Pins

Read each step carefully before starting. Each step of instruction should be performed in the correct order. If these steps are not followed in sequence, assembly difficulties may occur.

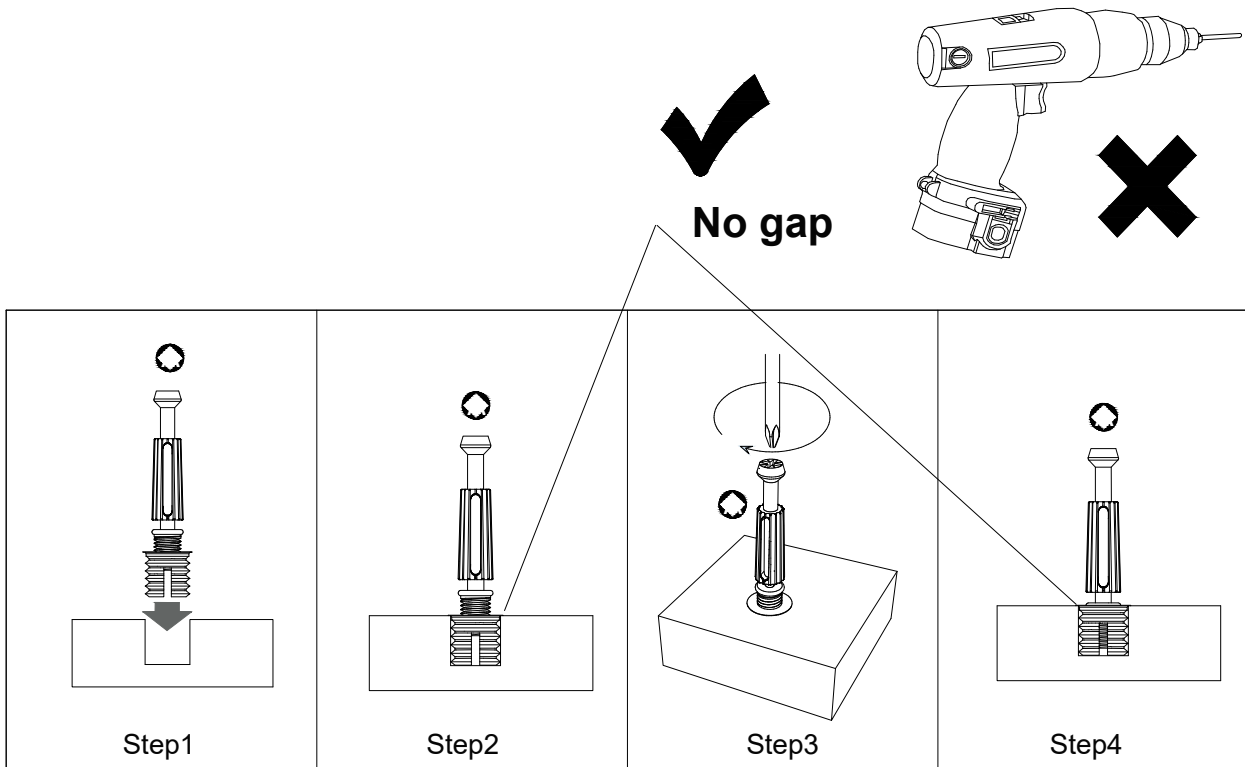

Screw the pin into the hole. Set the cams correctly by aligning the head of the cams with the lock pins. Lock the cam by turning the cam head with a screwdriver until it is tightened. Please do not use an electric screwdriver to assemble the unit.

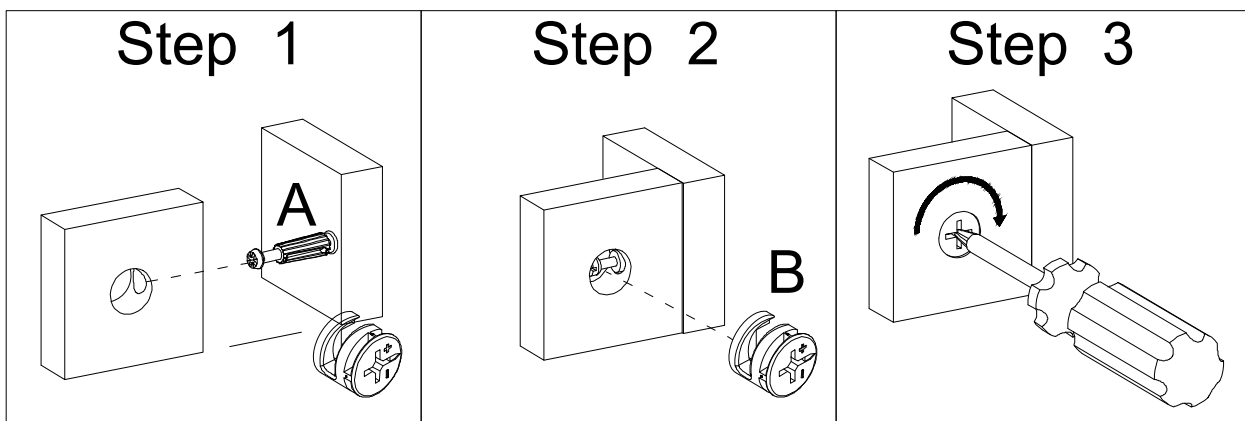

Please split component “H” into “H-1” and “H-2” before assembling the slide and then proceed to the next step of assembly

Step 1

Pull apart component "H" to each side, and then gently push up the lever of component "H-2"

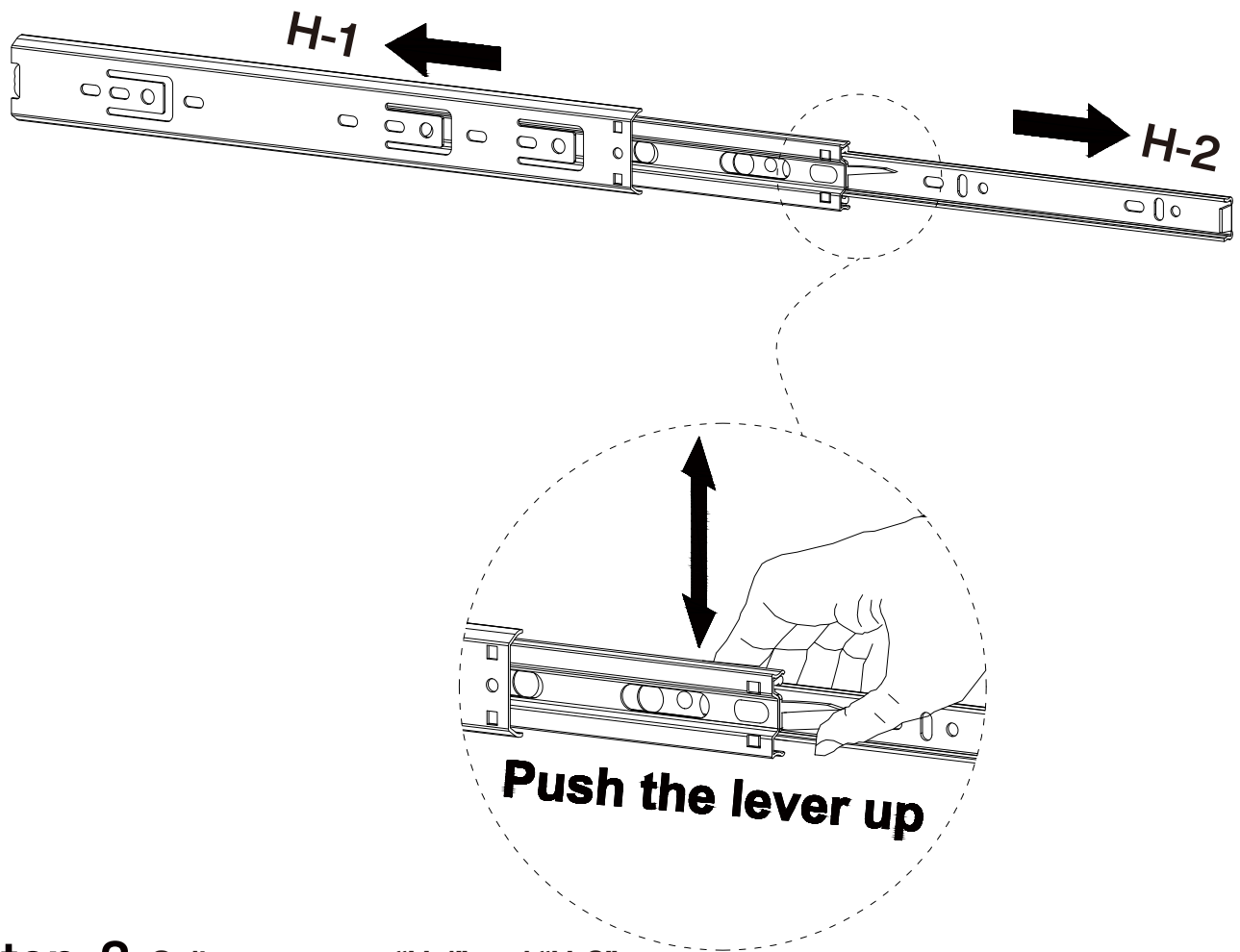

Step 2 Split component “H-1” and “H-2”

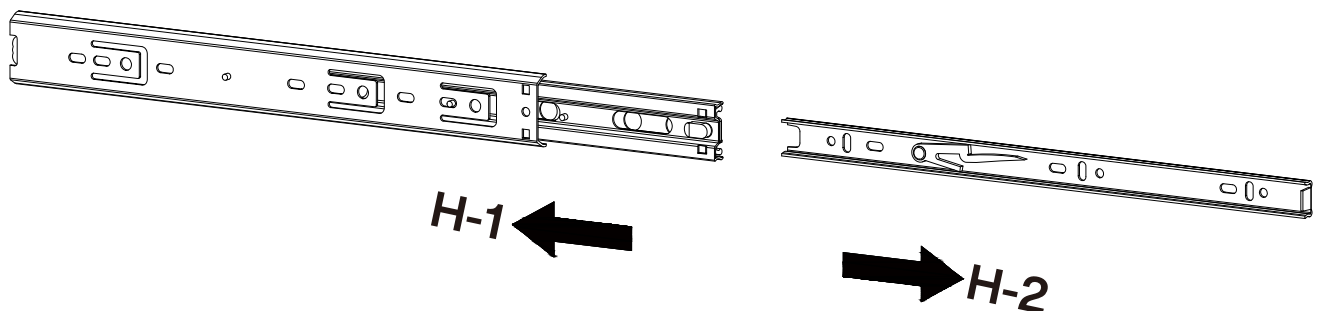

1

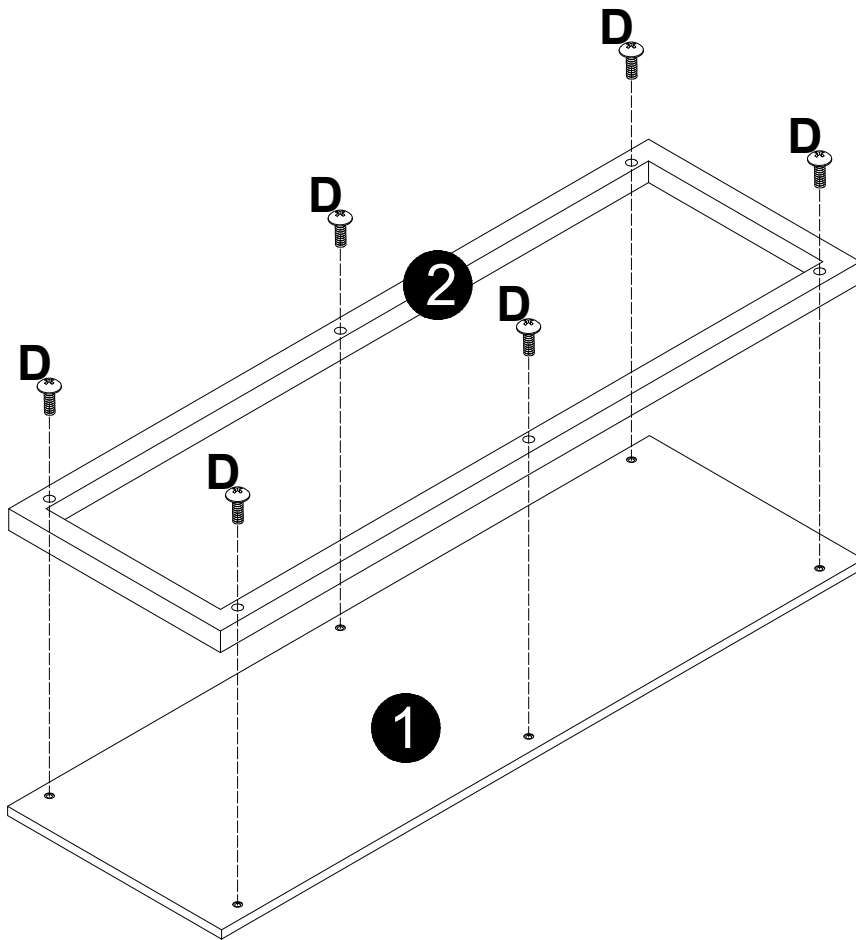

D
 Ø6x12mm
6 pcs

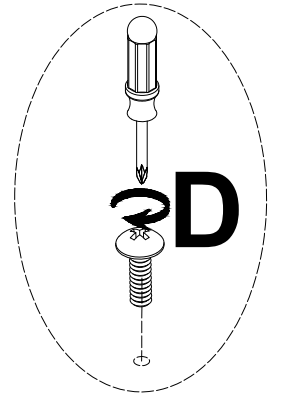

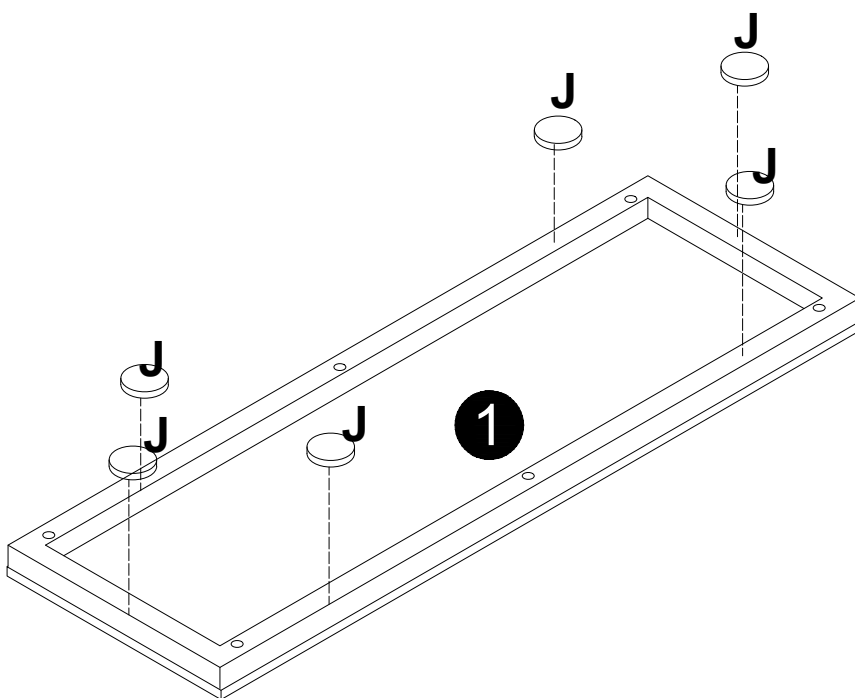

2

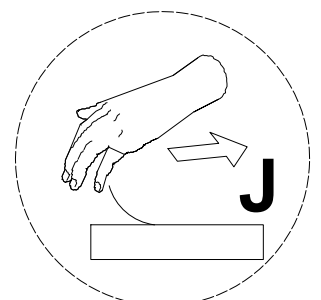

J

6 pcs

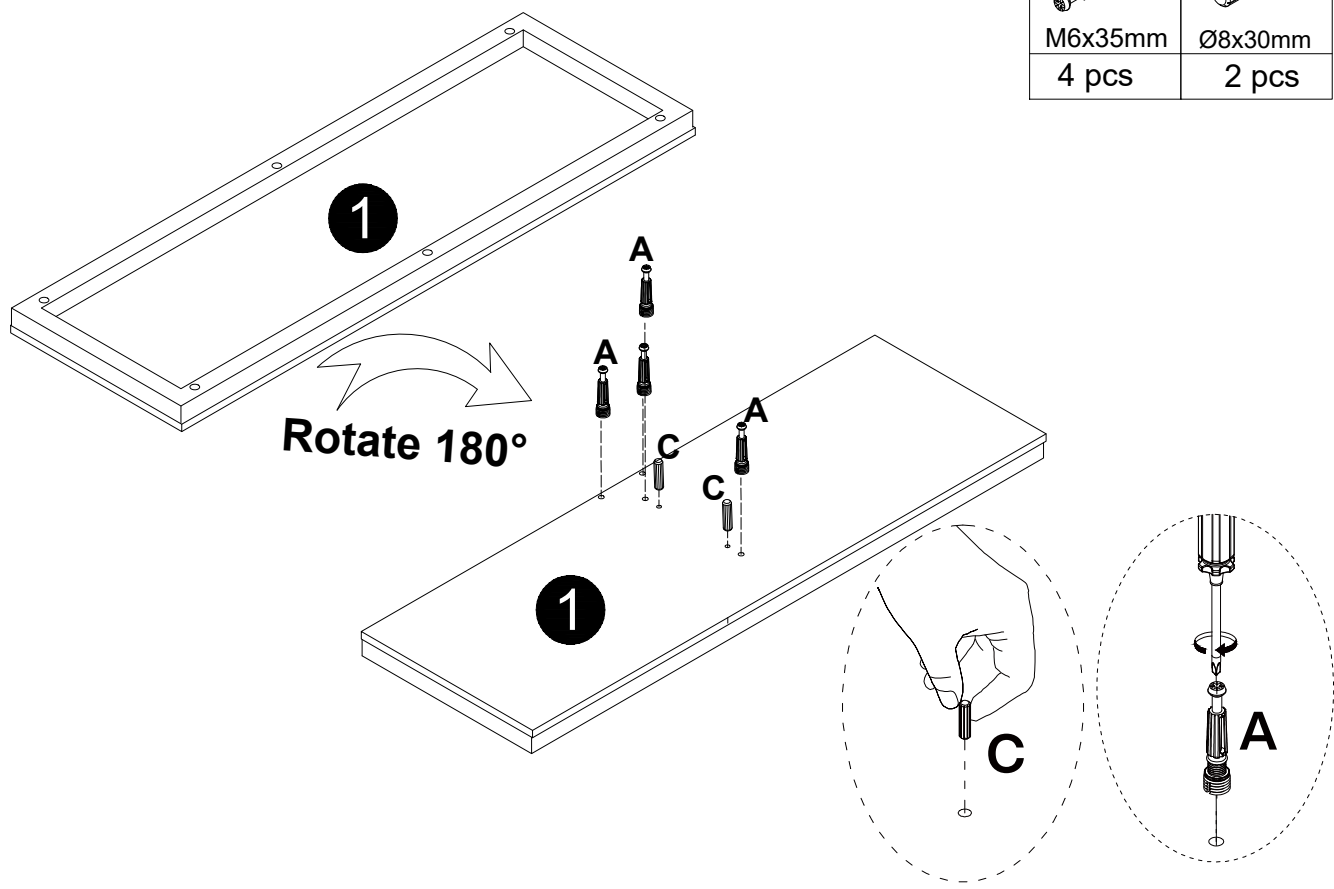

3

A	C
	
M6x35mm	Ø8x30mm
4 pcs	2 pcs



4

I

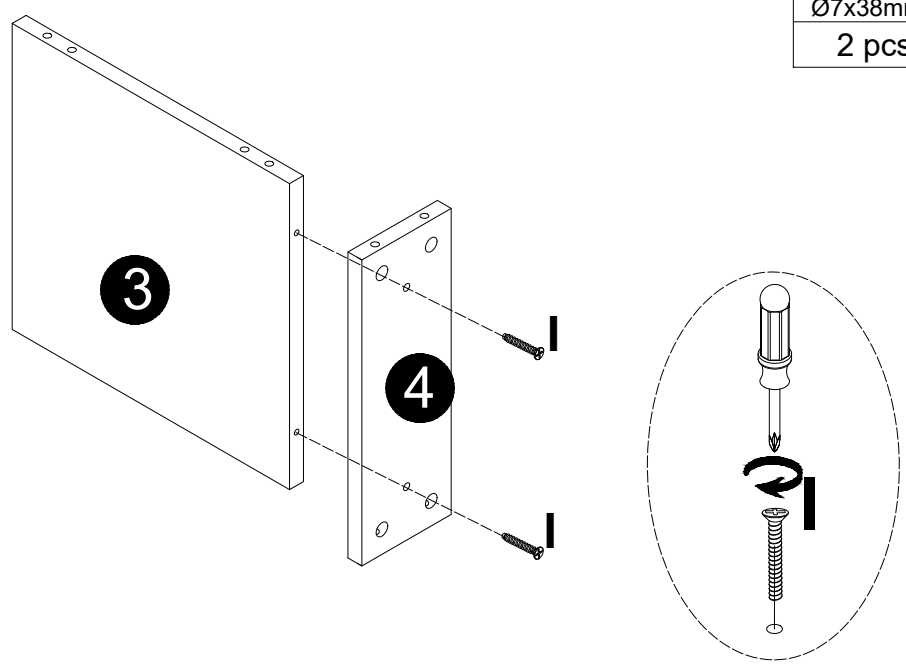
Ø7x38mm
2 pcs



5

B

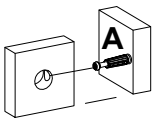
Ø15x12mm
4 pcs

Step 1

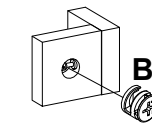

Step 2



Step 3

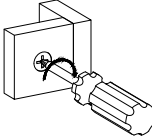

Step 4

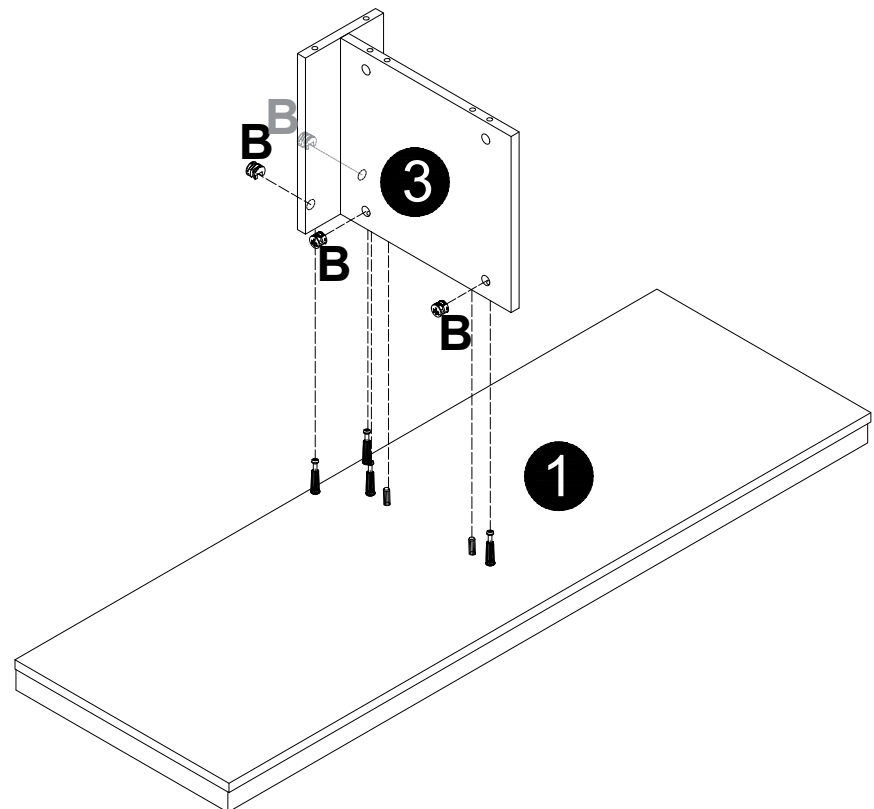
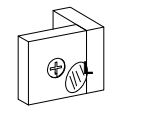

6

A

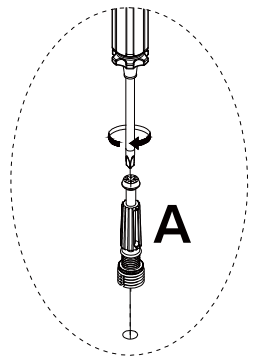
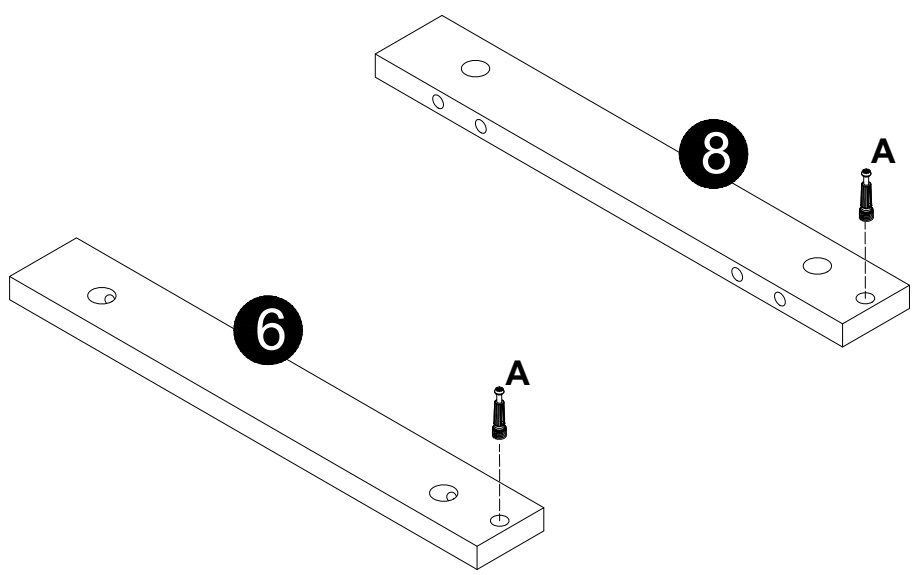
M6x35mm
2 pcs



7

B

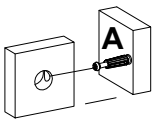
Ø15x12mm
2 pcs

Step 1

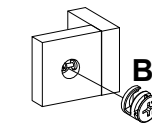

Step 2



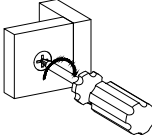

Step 3

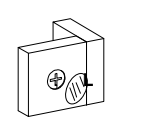
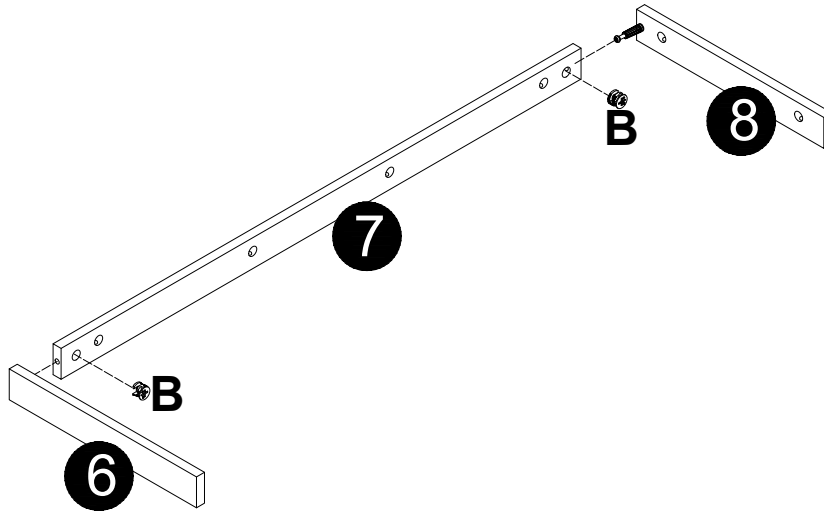

Step 4



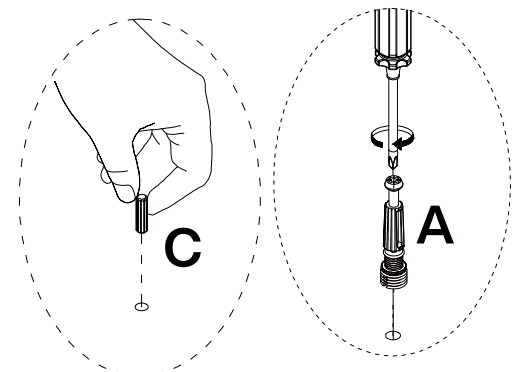
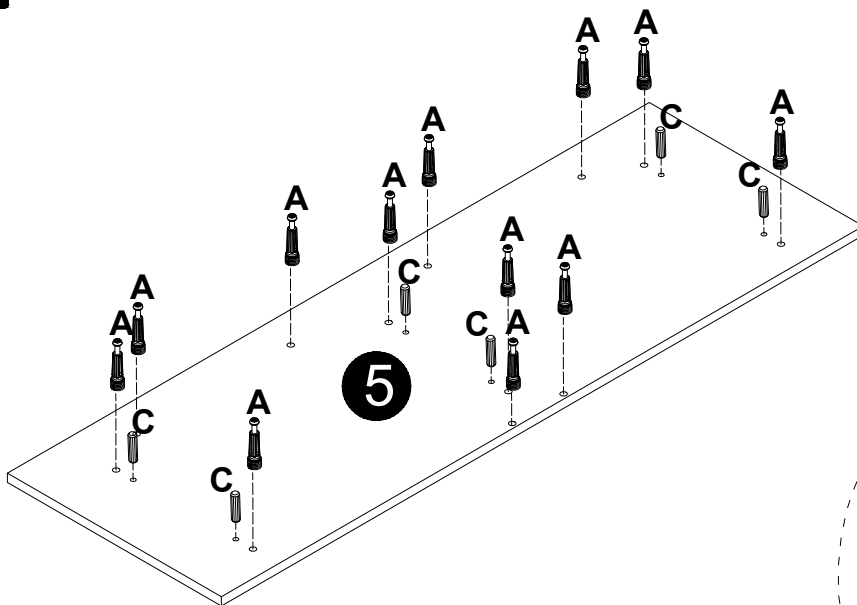

8

A	C
	
M6x35mm	Ø8x30mm
12 pcs	6 pcs



9

B

Ø15x12mm
8 pcs

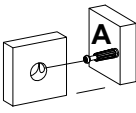
Step 1

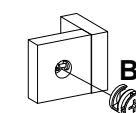

Step 2



Step 3

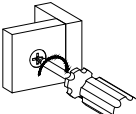

Step 4

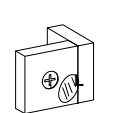
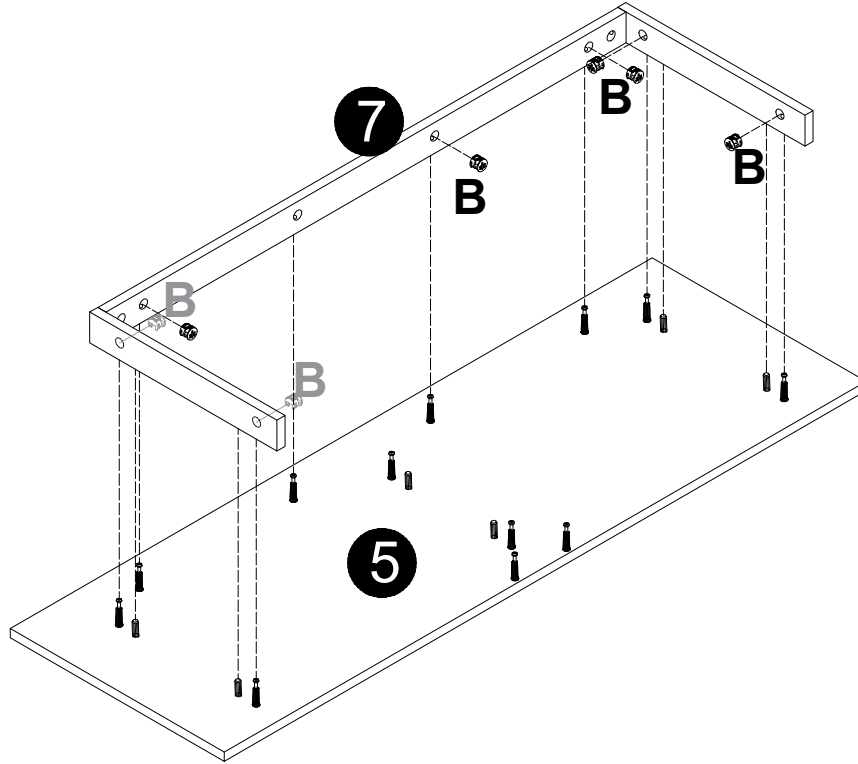
10

B

Ø15x12mm
4 pcs

Step 1

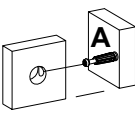

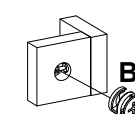
Step 2



Step 3

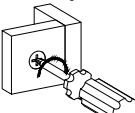

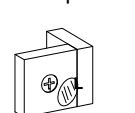
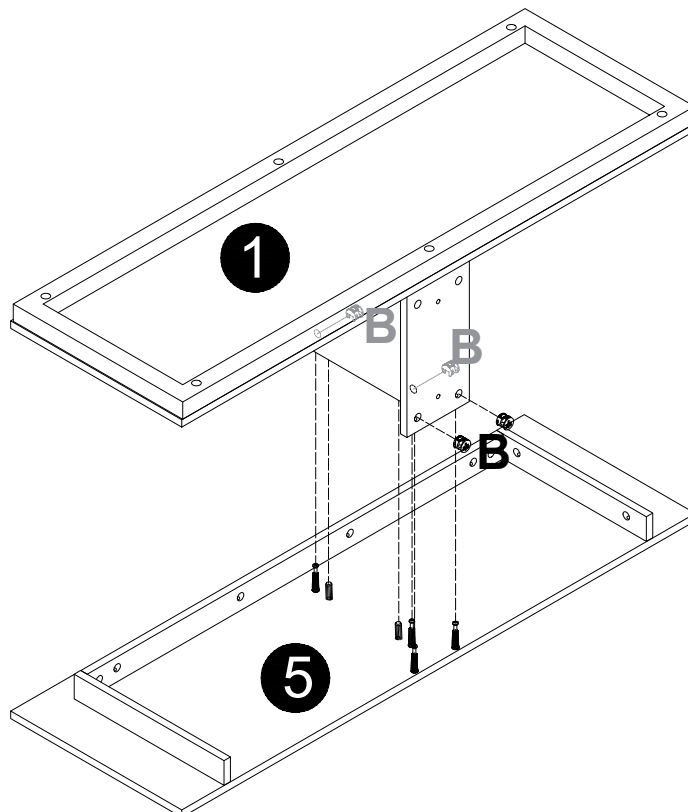

Step 4

11

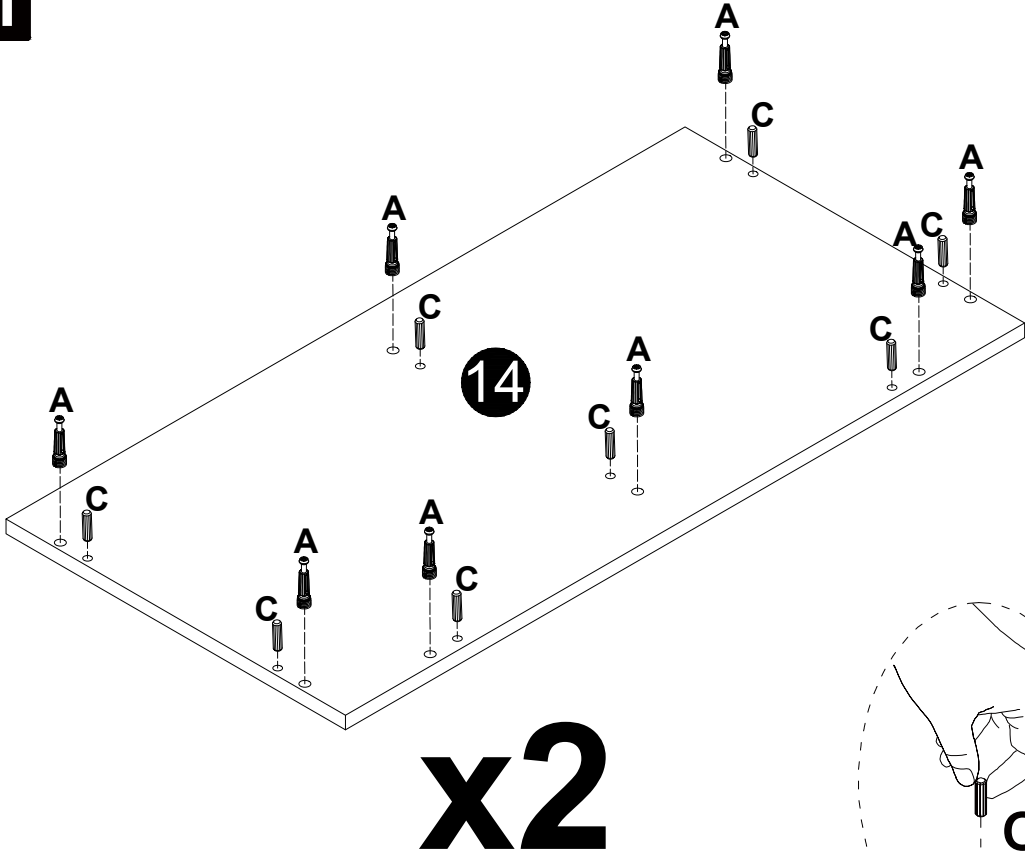



A	C
	
M6x35mm	Ø8x30mm
16 pcs	16 pcs

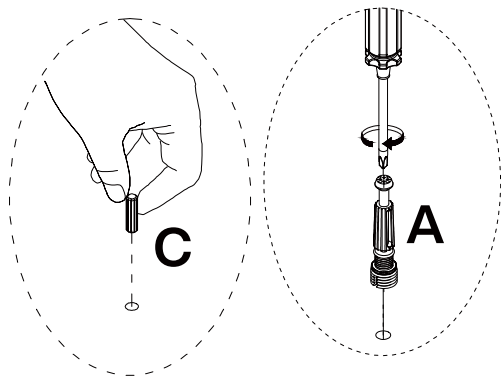

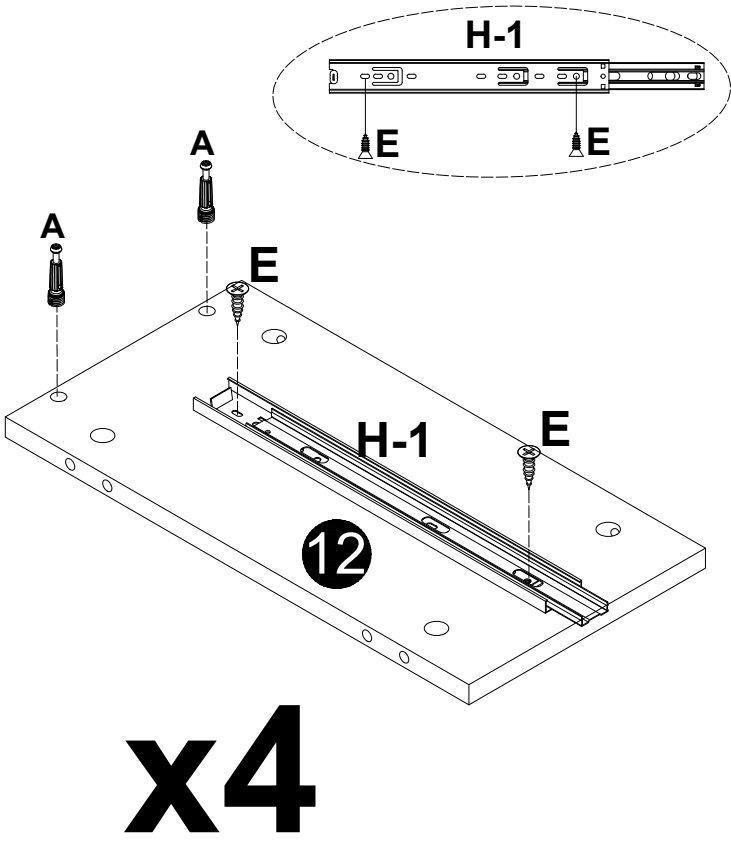
12



H	A
	
4 pcs	M6x35mm
	8 pcs
E	
	
Ø3.5x14mm	
8 pcs	

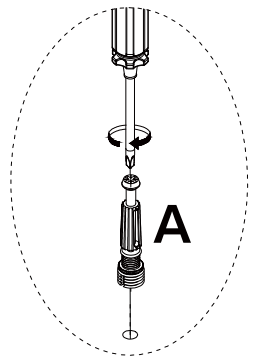

13

B

Ø15x12mm
8 pcs

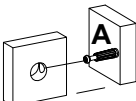
Step 1

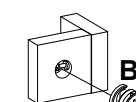

Step 2



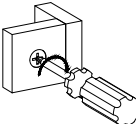

Step 3

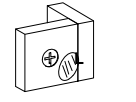
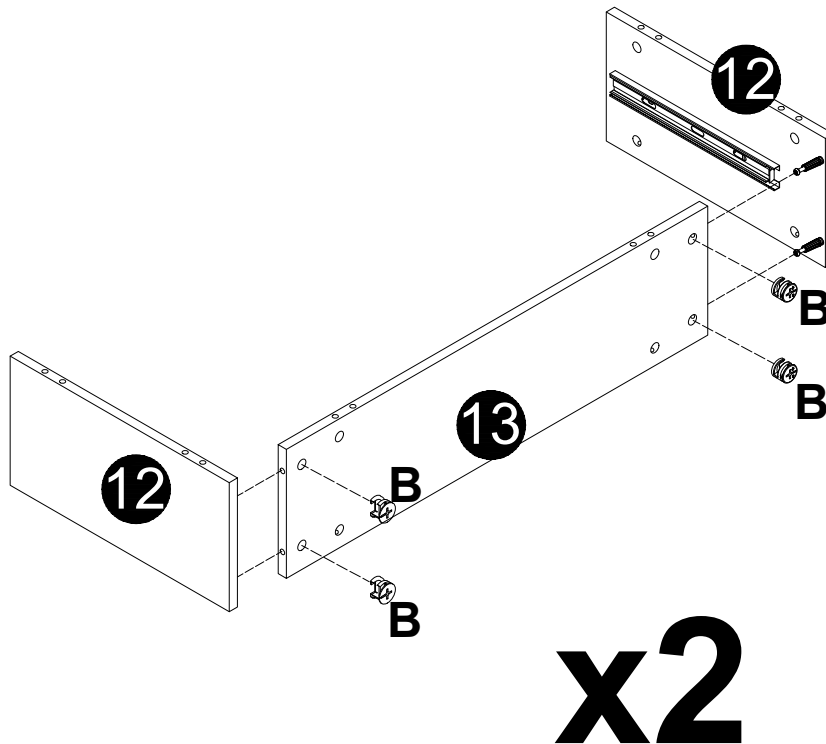

Step 4



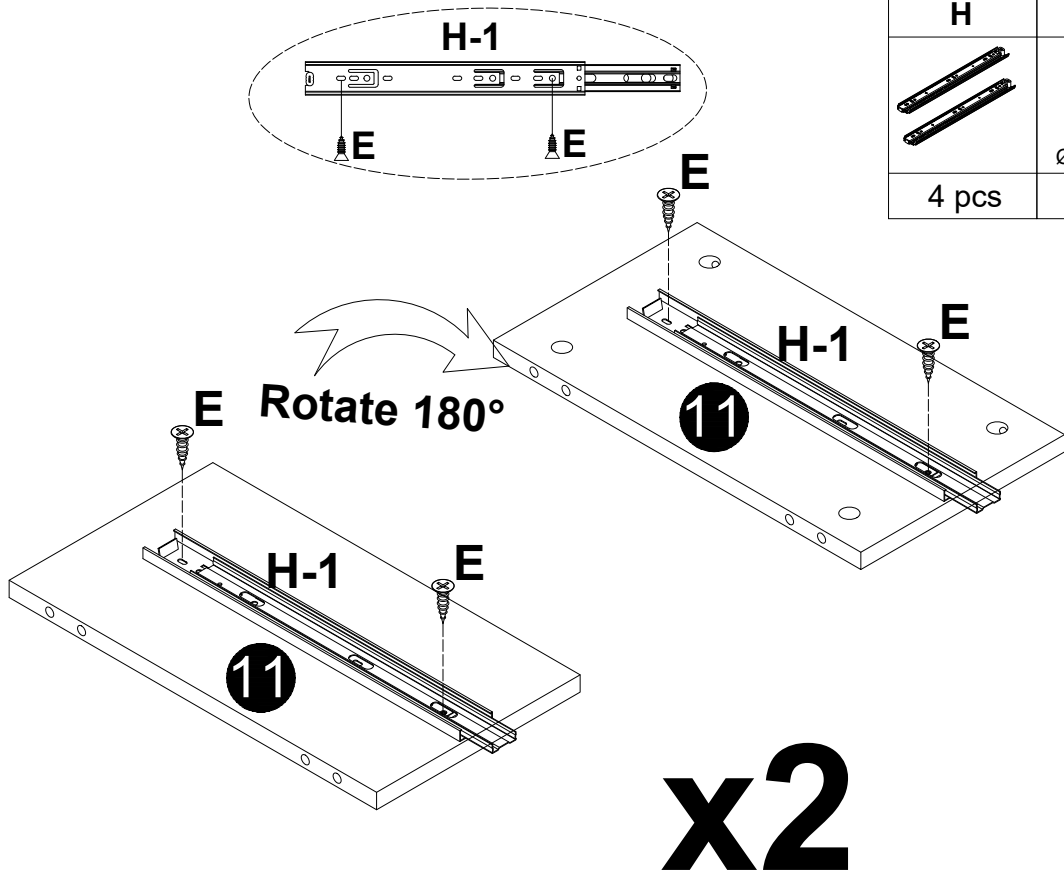

14

H	E
	
4 pcs	Ø3.5x14mm
4 pcs	8 pcs

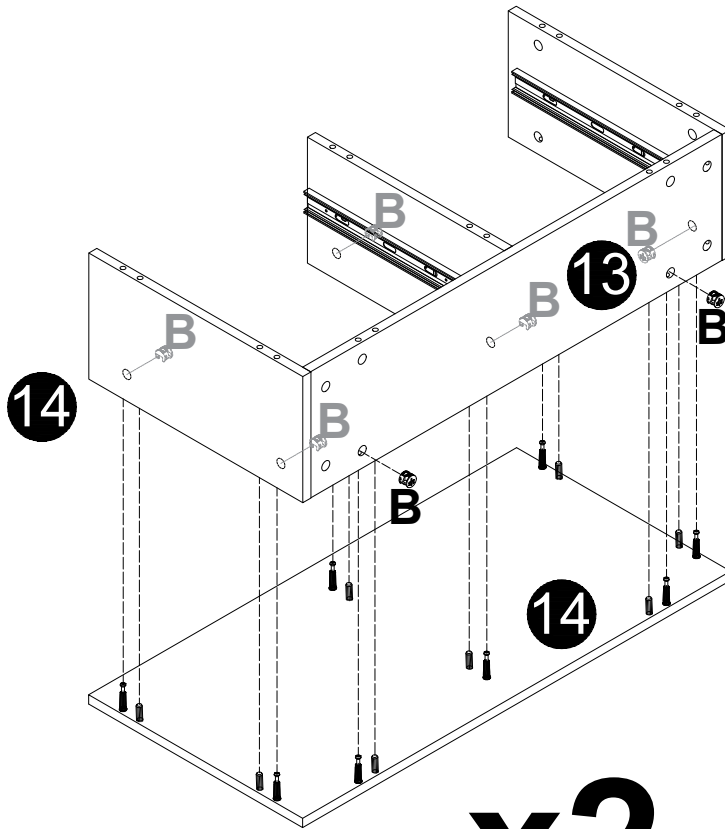
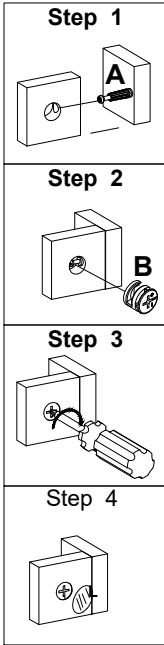

15





B

Ø15x12mm
16 pcs

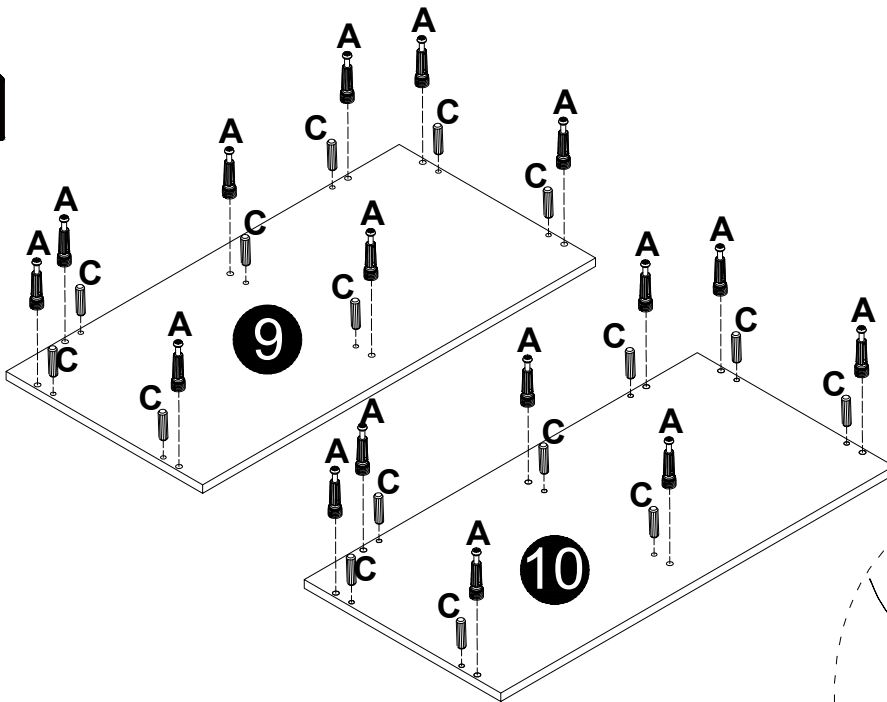
x2

16

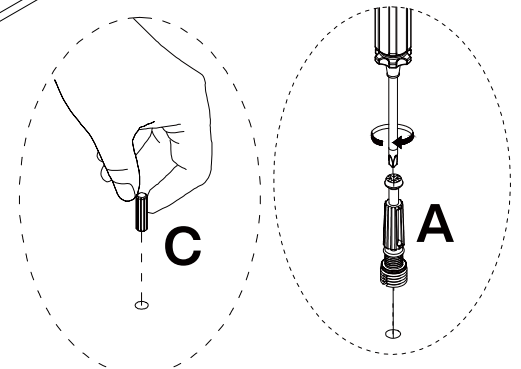

A	C
	
M6x35mm	Ø8x30mm
16 pcs	16 pcs



17

B
 Ø15x12mm
8 pcs

Step 1

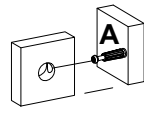

Step 2

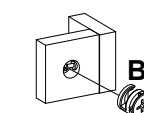

Step 3

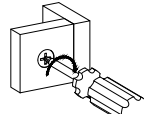

Step 4

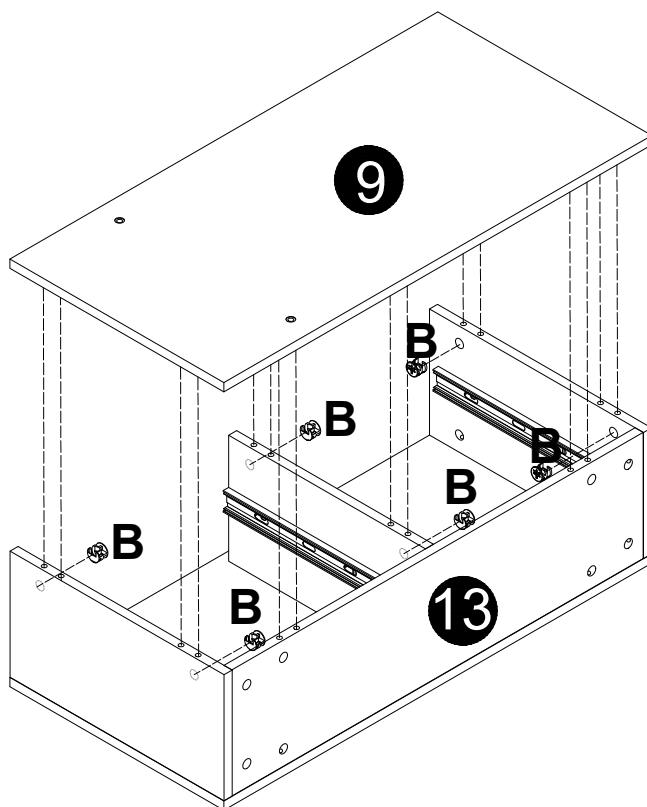
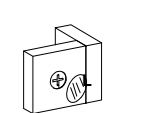

18

B
 Ø15x12mm
8 pcs

Step 1

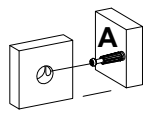

Step 2

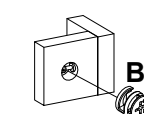

Step 3

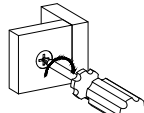

Step 4

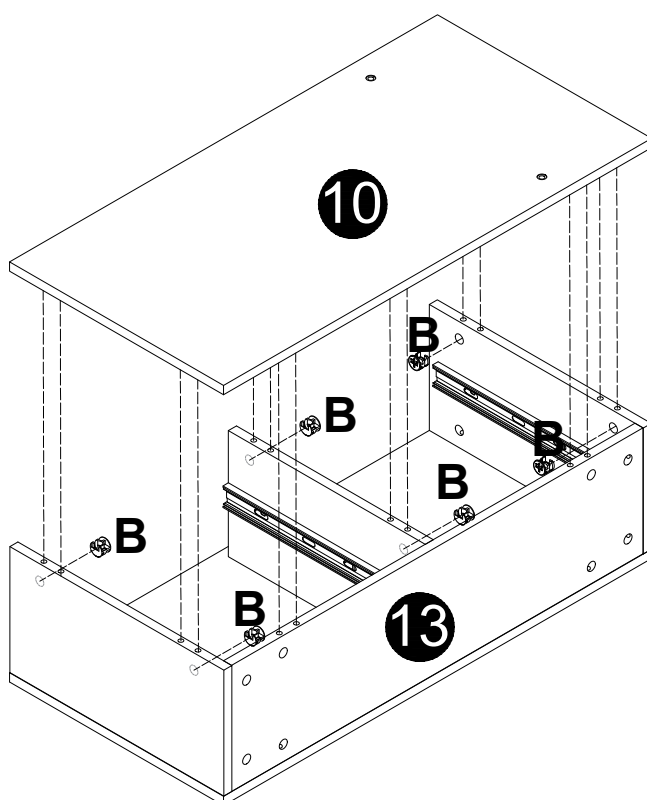
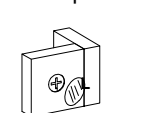

15

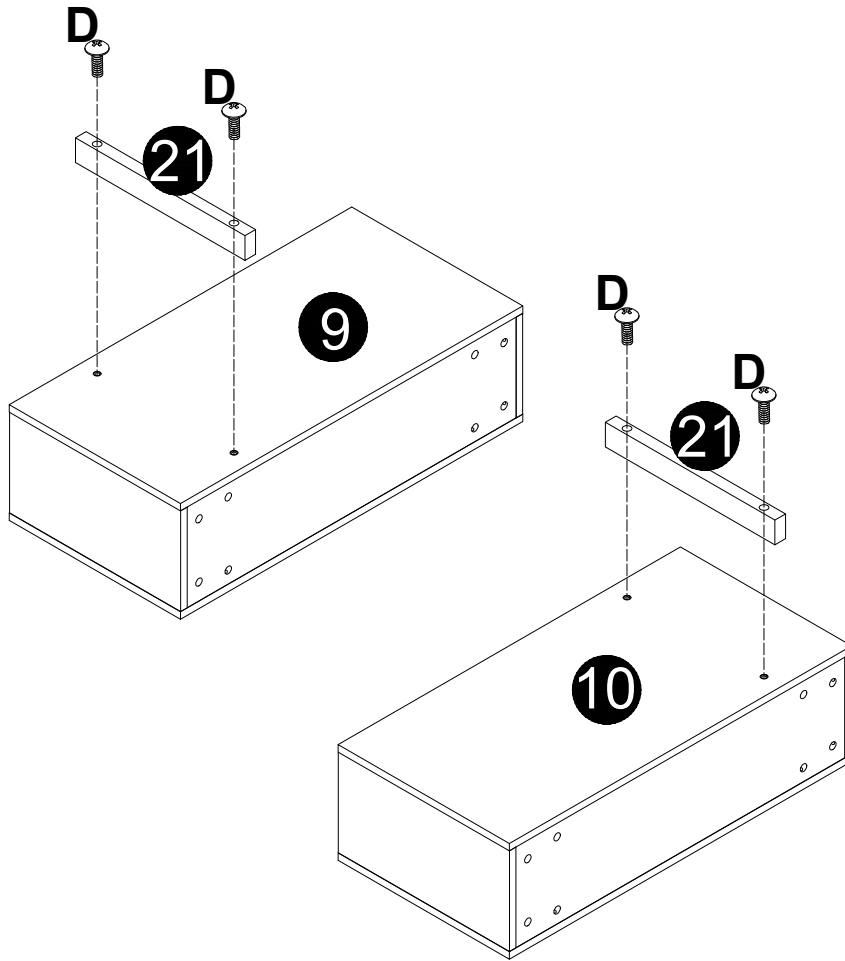

D
 Ø6x12mm
4 pcs

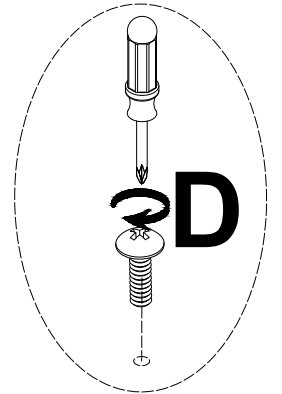

16

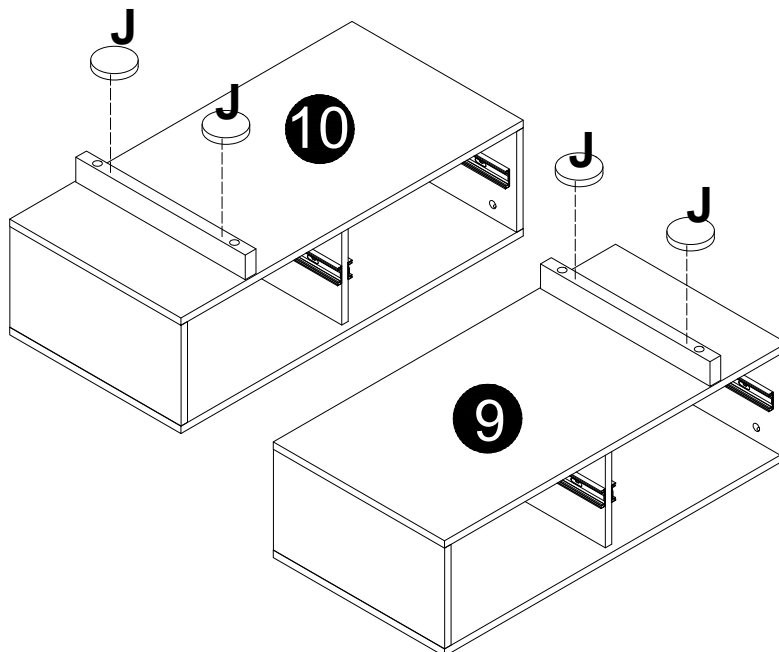

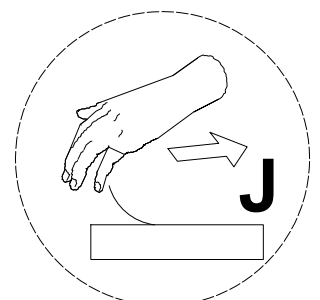

J

4 pcs

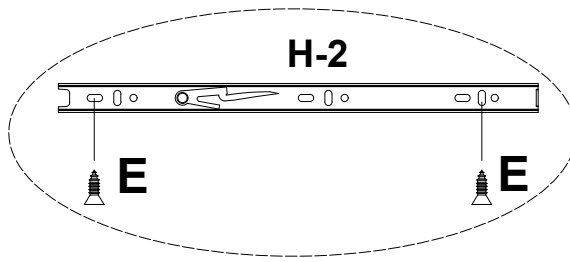

17

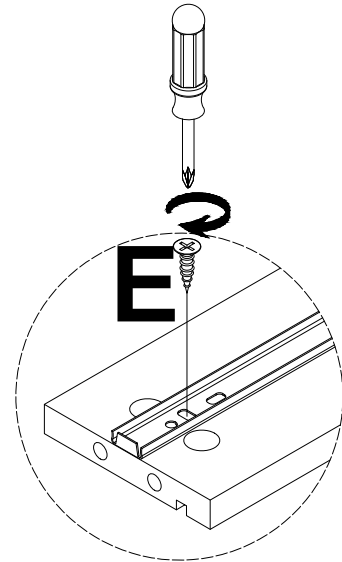
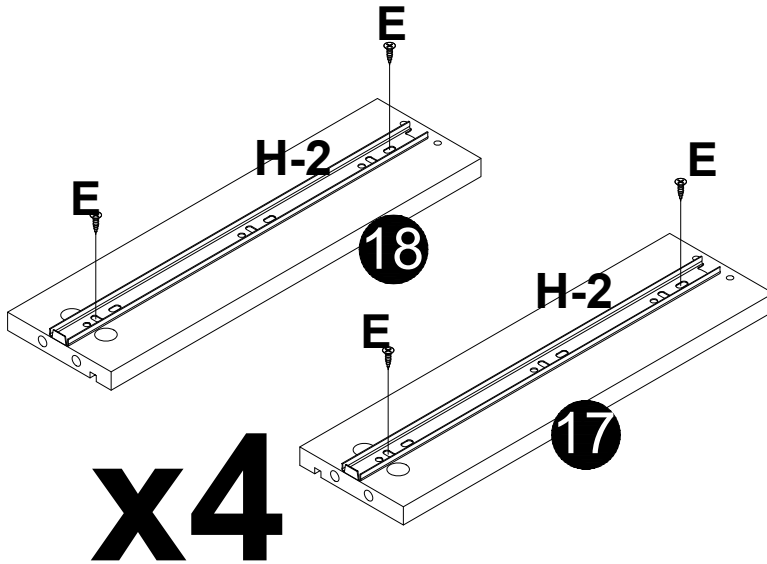

e	H
	
Ø3.5x14mm	
16 pcs	8 pcs



18

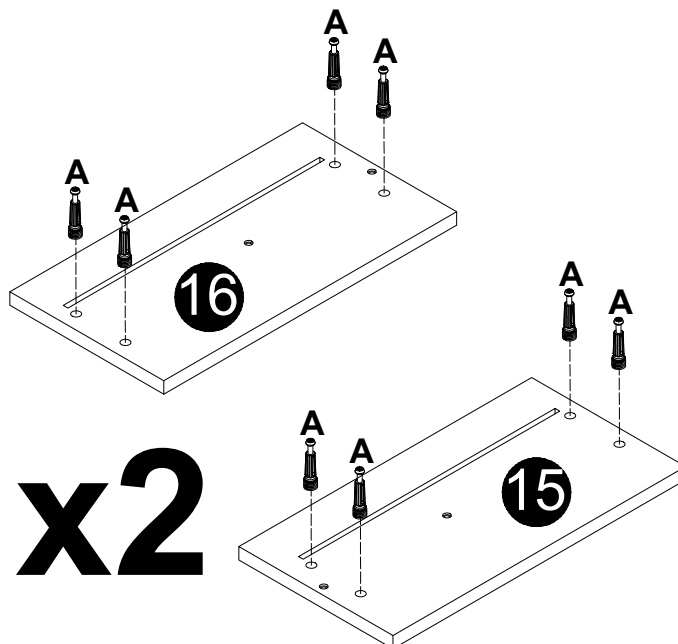

A

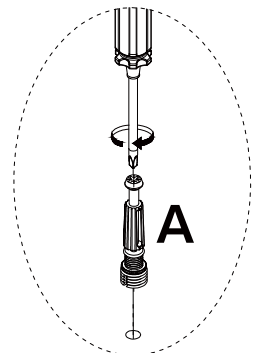
M6x35mm
16 pcs

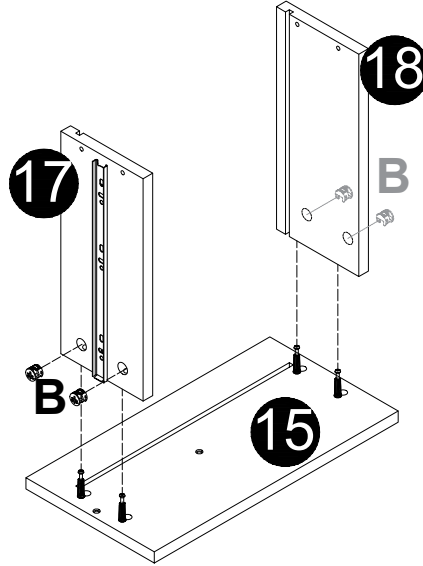
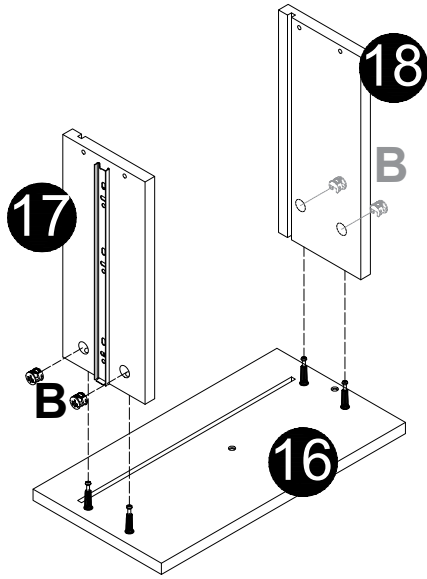
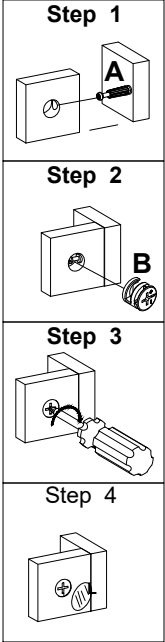

19



x2

B

Ø15x12mm
16 pcs

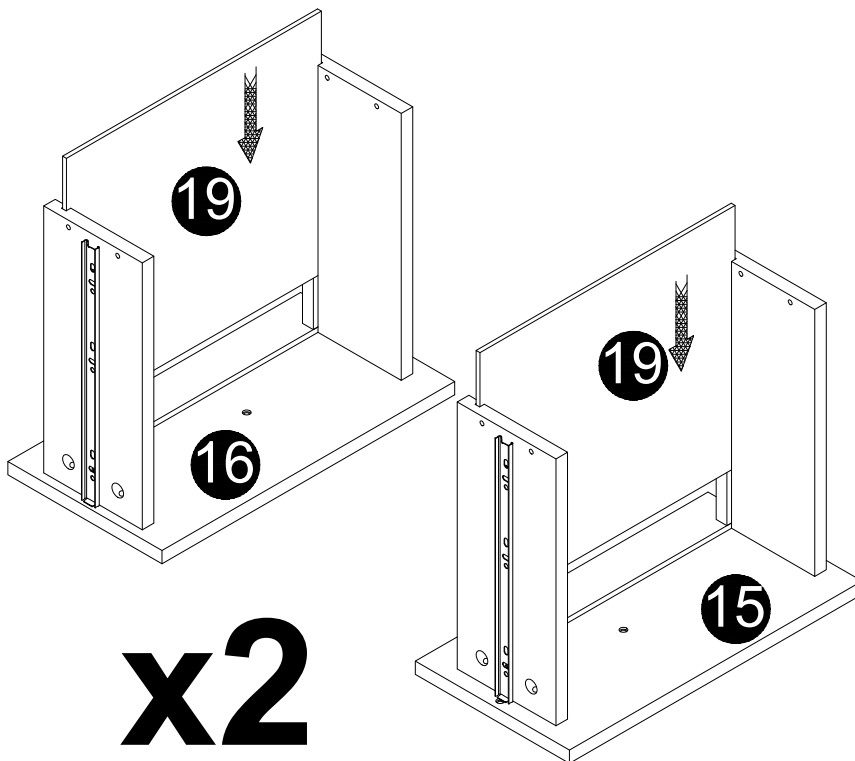
20

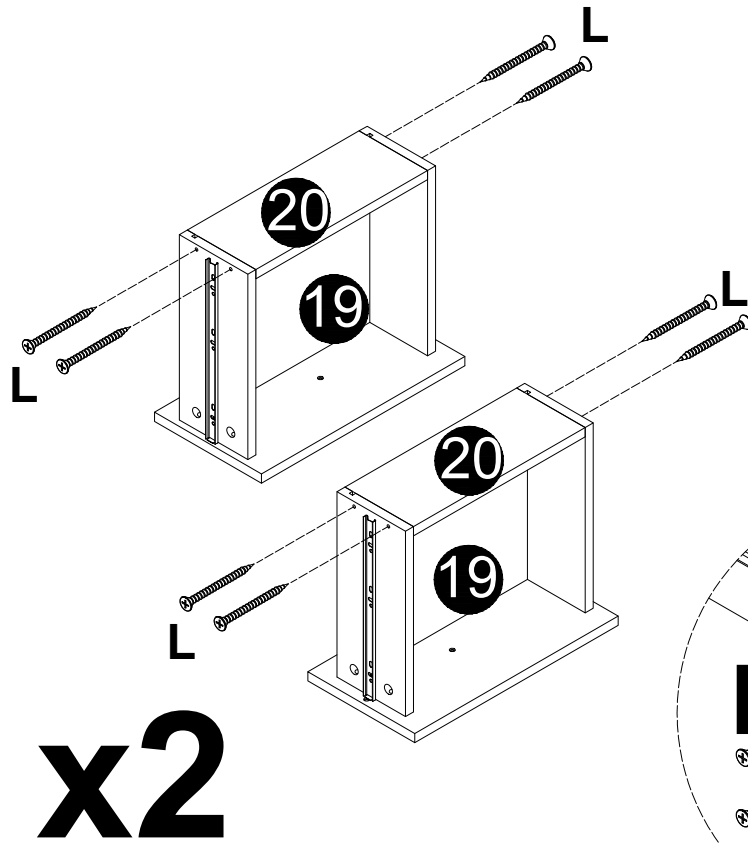

x2

21





L

Ø3.5x35mm
16 pcs

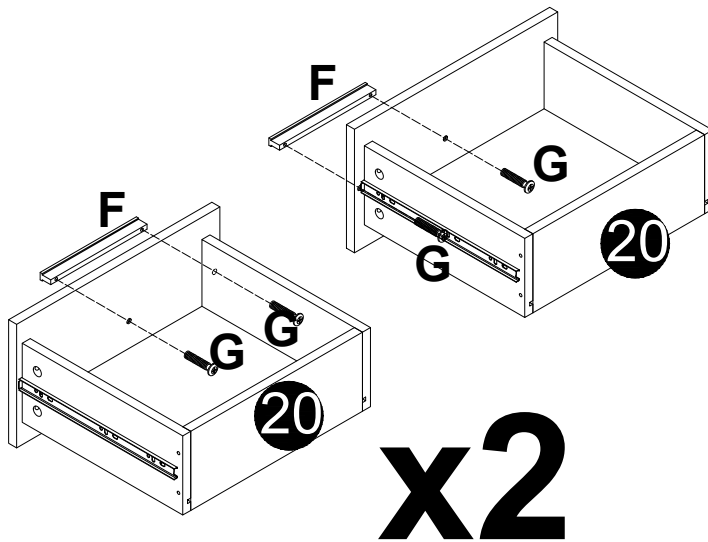
x2

22



F	G
	
4 pcs	Ø4x16mm
	8 pcs

x2

23

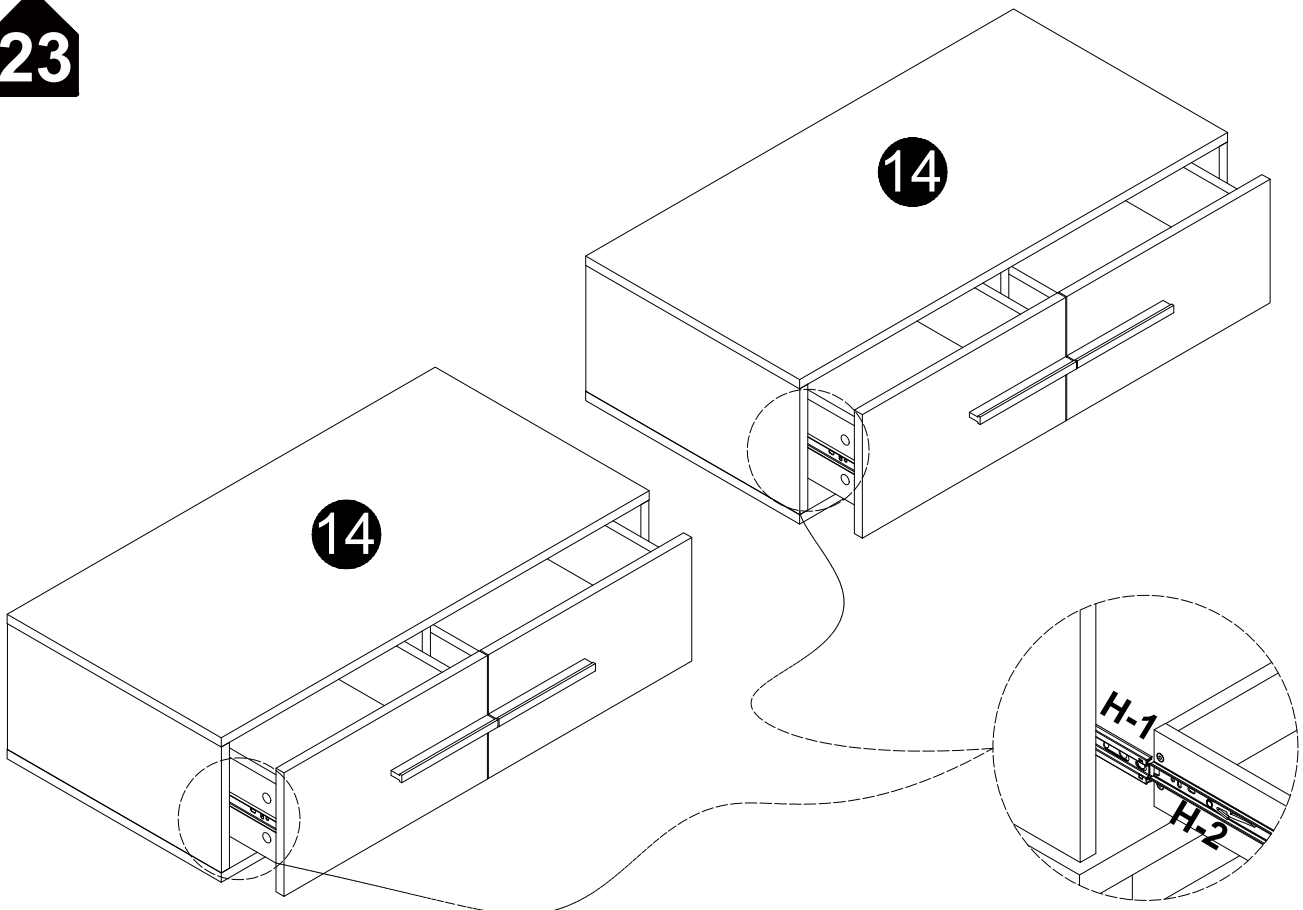

Align the "H-2" with the "H-1" guideway and gently push it in to complete the assembly

24

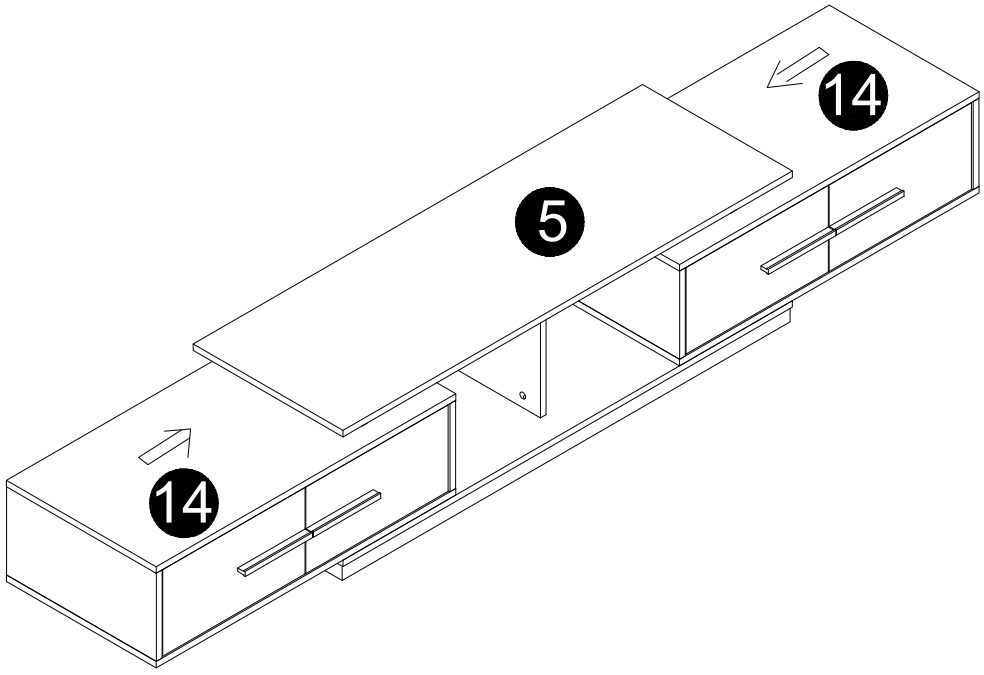

Thank you for your support!

