

ASSEMBLY INSTRUCTIONS (please read carefully before assembly)

ACCESSORIES

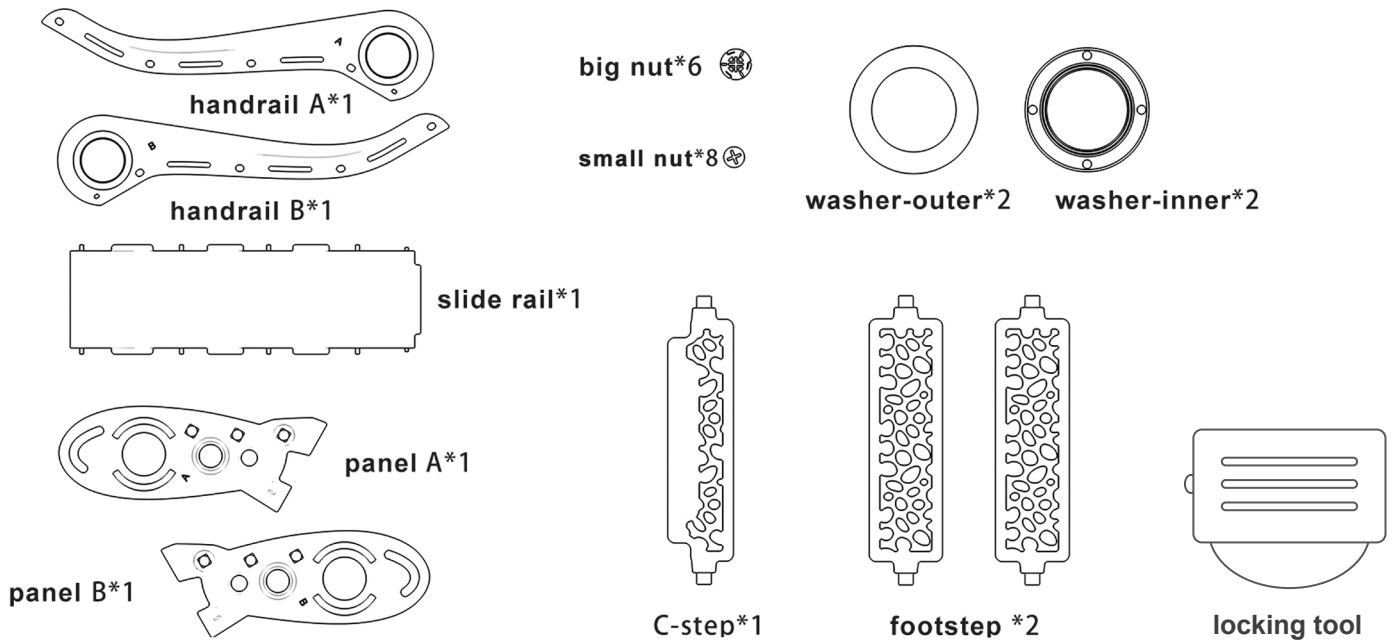

STEP BY STEP ASSEMBLY

The product should be assembled by an adult – please make sure all plastic wrapping is disposed of to avoid risk of suffocation

STEP 1

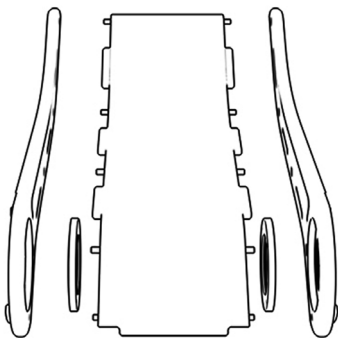

Place handrail A and B to the slide rail as shown (and insert washer inner 2).

STEP 2

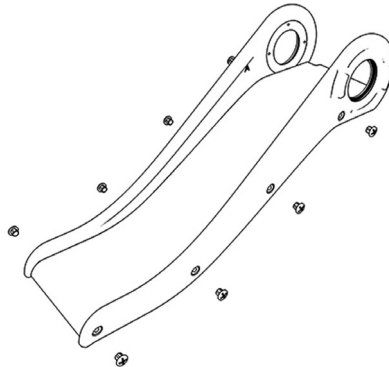

Secure handrails in place using the 8 small nuts and locking tool.

STEP 3

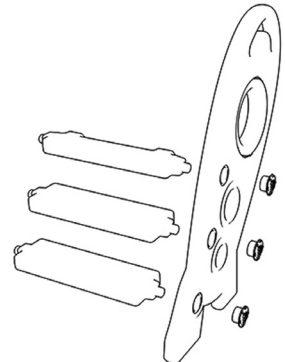

Fix steps to panel A as shown in illustration (C step to top rail) – tighten 3 nuts with locking tool.

STEP BY STEP ASSEMBLY

STEP 4

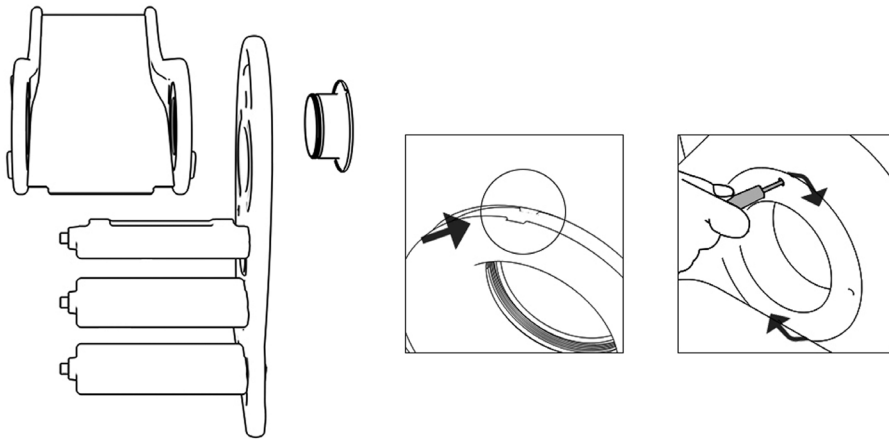

Connect the part assembled handrail to the main slide (as shown) and insert x1 washer outer.

Important – you will notice that one of the washers is threaded like a screw. It is important that you apply enough pressure using both hands – one to hold a washer still – the other to rotate the other washer so that it tightens – like a screw. It may be useful to use an object (like a screwdriver) to achieve more force – just place screwdriver into washer hole and rotate clockwise whilst holding the other washer still by hand until fully screwed in place.

STEP 5

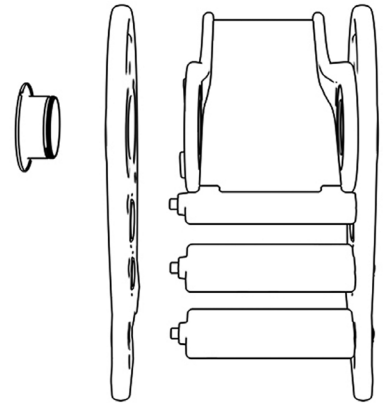

Connect the other handrail using screws and washers.

STEP 6

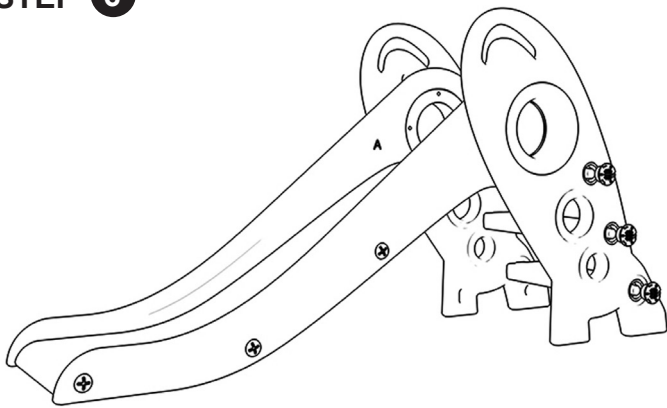

Make sure all screws are securely tightened before use.

FINISH

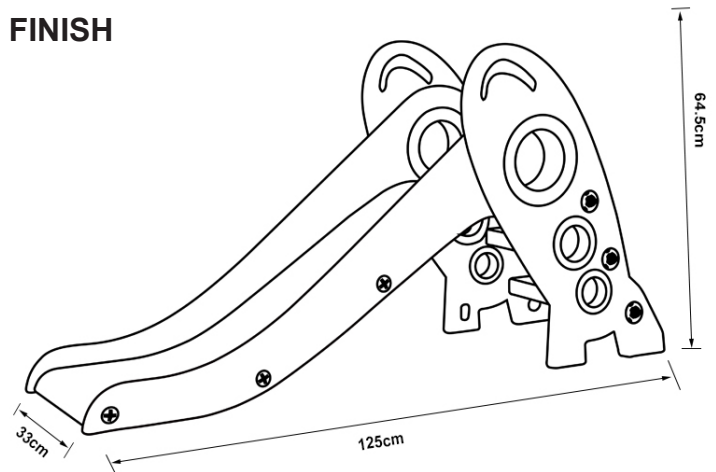

MAINTENANCE

1. Check parts from time to time to ensure that all screws are secure (so keep locking tool in safe place).
2. The slide steps have anti slip styling/patterns – these can become soiled over time – so please clean often.
3. Cleaning should be carried out with a damp cloth and warm water (you can use diluted cleaning liquid) – we do not advise using acidic or abrasive cleaning liquids.
4. The product can be used indoors and outdoors but avoid high temperatures and avoid prolonged periods of direct sunlight – over a period direct sunlight can affect colour fastness.



WARNING:
CHOKING HAZARD – Small parts.