

# ASSEMBLY INSTRUCTIONS

## DINING CHAIR

ASSEMBLY  
REQUIREMENTS

30 MINUTES  
Assembly Time  
Approximate

1-Person  
Assembly

Tools Required  
(Not Provided)

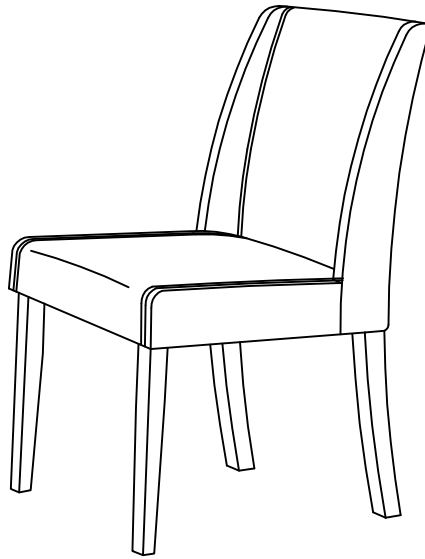

### ASSEMBLY PREPARATION

1. Remove all packaging materials, staples and packing straps from the carton.
2. Refer to Parts List and Hardware List, and ensure parts and hardware are correct before assembly.
3. Contact customer service for missing parts.
4. Place all wooden parts on a clean, flat and soft surface (e.g. carpet or rug) to prevent parts from getting scratched.

### SAFETY PRECAUTION

1. KEEP ALL HARDWARE PARTS OUT OF REACH OF CHILDREN.
2. DISPOSE PLASTIC PACKAGING MATERIAL IMMEDIATELY TO AVOID ANY RISK OF SUFFOCATION TO CHILDREN AND ANIMALS.

### TIPS FOR ASSEMBLY

1. Allow ample room for assembly and in close proximity to where product will be placed.
2. Assemble the product on a surface that does not scratch or damage the exterior gloss and finish of the furniture.
3. Identify all of the parts, hardware and quantities required for each step.
4. During assembly, do not over-tighten any fittings as this may cause damage.
5. DO NOT USE POWER TOOLS TO ASSEMBLE THIS PRODUCT.
6. Always place the product on a flat, level surface.
7. Do not sit or stand on the partially assembled product; only use the product for which it is intended.

### CARE AND MAINTENANCE

- Use a slightly damp cloth to clean the product. Do not use bleach or abrasive cleaning material.
- Check all the fittings periodically and re-tighten as necessary. Do not use the product if any of the parts is damaged or broken.
- Never allow any kind of liquid to remain on your furniture. Absorption can cause wood to warp or delaminate.
- Do not place hot items (e.g. hot drinks) directly onto the wood surface.
- Do not drag and/or pull the furniture.

This product is for indoor and household use only - not for commercial use.







# ASSEMBLY INSTRUCTIONS

## DINING CHAIR

### PARTS LIST (FOR 2 COMPLETE CHAIR)

NO.	DESCRIPTION	QTY
P1	CHAIR BACK	2
P2	CHAIR SEAT	2
P3	FRONT LEG	4

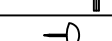
### HARDWARE LIST (FOR 2 COMPLETE CHAIR)

NO.	DESCRIPTION	QTY	EXTRA
H1	JCBC SCREW M6 x 80mm 	8	1
H2	JCBC SCREW M6 x 50mm 	8	1
H3	JCBC SCREW M6 x 40mm 	4	1
H4	SPRING WASHER 	20	1
H5	FLAT WASHER 	20	1
H6	ALLEN KEY 	1	
H7	LEG STUD 	8	1

\* Extra Hardware For Spare Use

## STEP 1

- Lay Chair Back (P1) flat down on a material that does not scratch or damage the part.
- Place Chair Seat (P2) on Chair Back (P1) aligning the center screw holes on (P2) to center screw holes on (P1).
- Insert JCBC Screw (H3) fitted with Spring Washer (H4) and Flat Washer (H5) into middle screw hole. Use Allen Key (H6) to drive (H3). Do not tighten (H3) completely at this time.

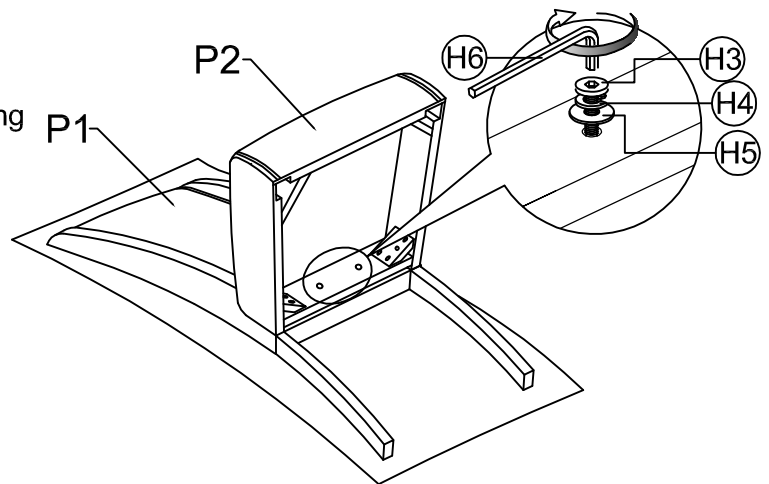

\*Take Care not to exert pressure on Chair Back(P1)  
Exerting pressure on Chair Back in this position can cause irreparable damage.

## STEP 2

- Use Allen Key (H6) to drive JCBC Screw (H1) fitted with Spring Washer (H4) and Flat Washer (H5) into screw holes on the rear, right corner blocks on(P2). Do not tighten the screws completely at this time.
- Repeat the above assembly procedure for the rear, left corner of (P2).
- Tighten JCBC Screw (H3) from Step 1 and all of the JCBC Screws (H1) in this step completely at this time. Do not over-tighten the screws.

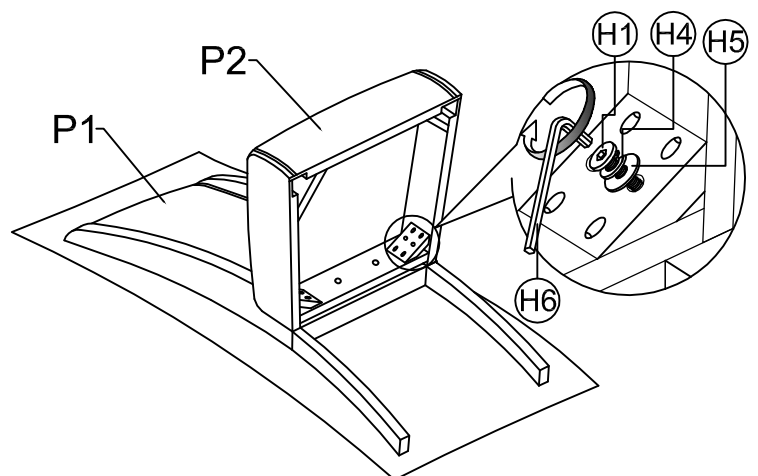

\*Take Care not to exert pressure on Chair Back(P1)  
Exerting pressure on Chair Back in this position can cause irreparable damage.

# ASSEMBLY INSTRUCTIONS

## DINING CHAIR

### STEP 3

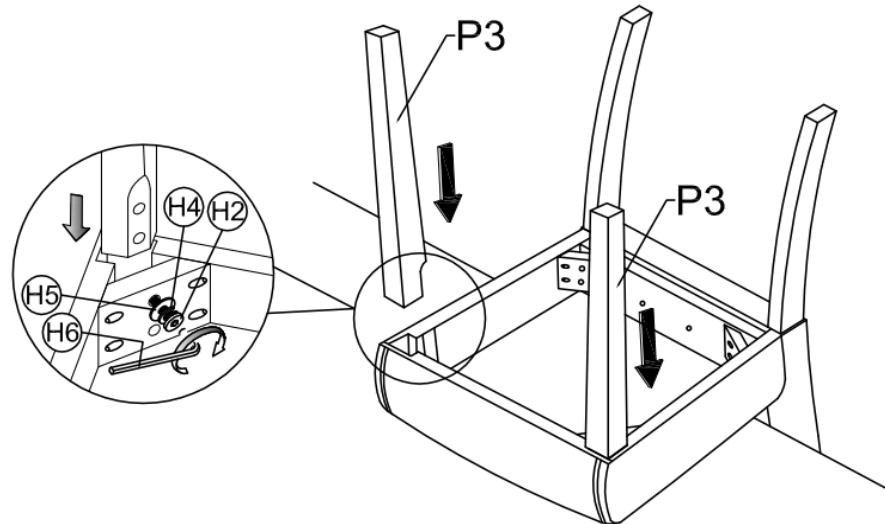

- a) Insert Front Leg (P3) as shown. Align the screw holes on (P3) to the screw holes on front corner block of (P2). Insert JCBC Screw (H2) fitted with Spring Washer (H4) and Flat Washer (H5) into each of the screw hole on the corner block. Use Allen Key (H6) to drive (H2) to fasten (P3) to (P2). Do not tighten (H2) completely until both (H2) are in place - do not over-tighten.
- b) Use the same assembly procedure above to install the other Front Leg.

### STEP 4

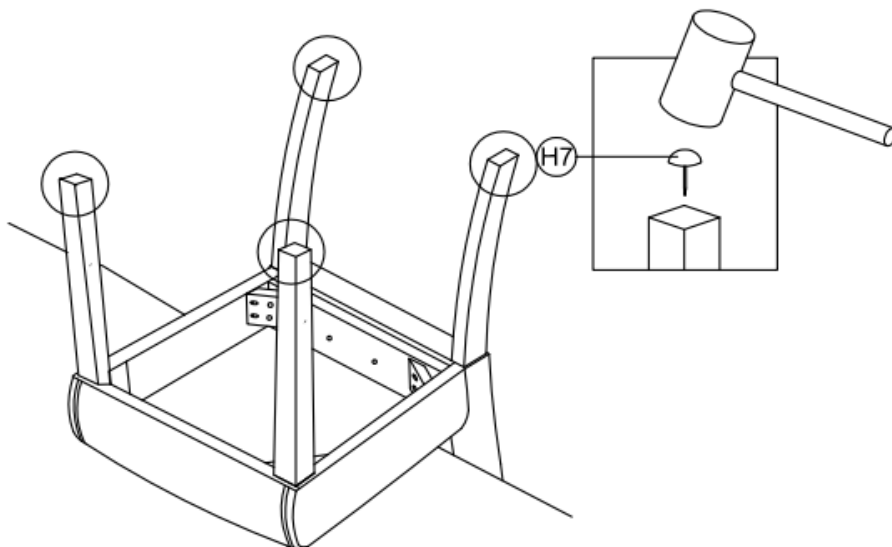

- a) Place the chair on an elevated surface (e.g. table top) .
- b) Use a mallet or hammer to gently nail leg stud (H7) into each of the leg.
- c) Place the chair right-side up. The assembly of chair is complete.