

ASSEMBLY INSTRUCTIONS

PLEASE READ BEFORE ASSEMBLING!

Tip #1: Make sure you've taken all the pieces and hardware out of its packaging before discarding the box.

Tip #2: Using page 2 and/or page 3 of instruction manual make sure all pieces and hardware are accounted for.

Tip #3: Read manual before assembling, it helps!

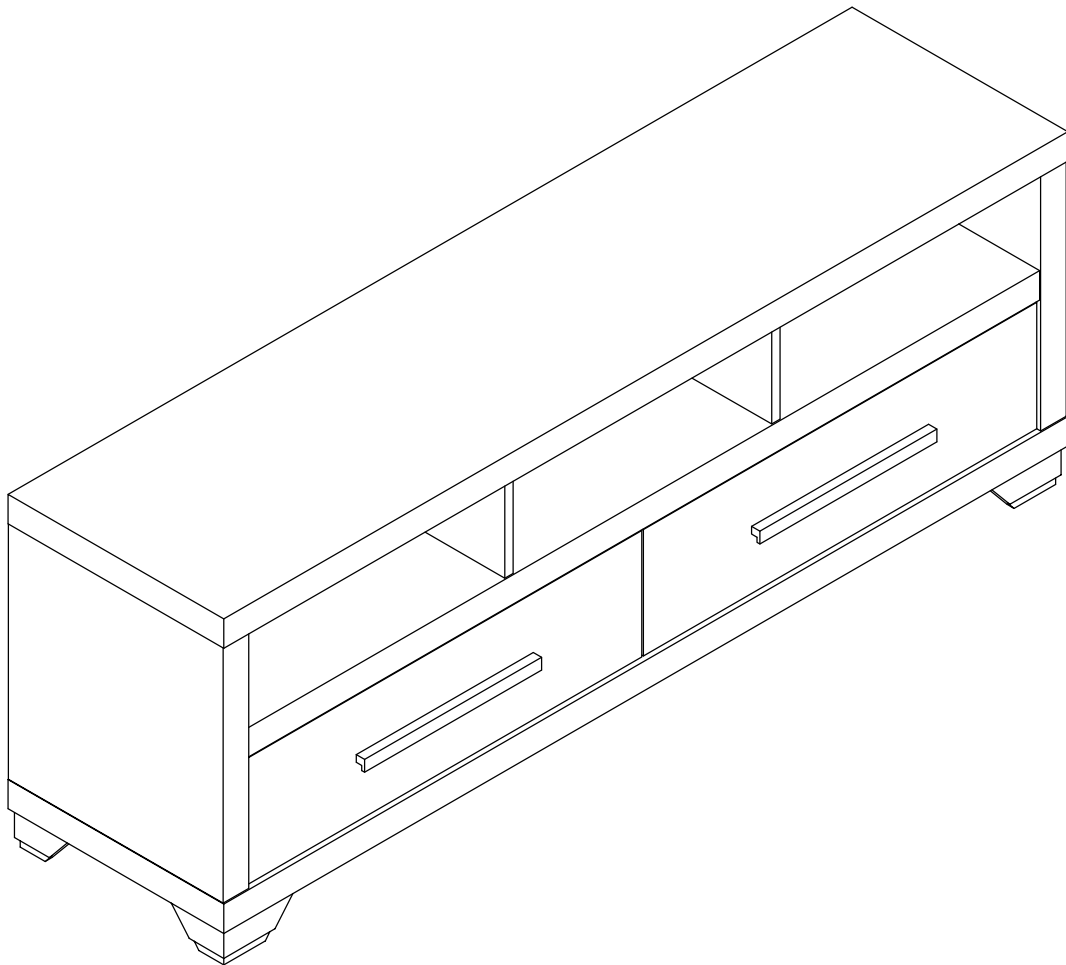



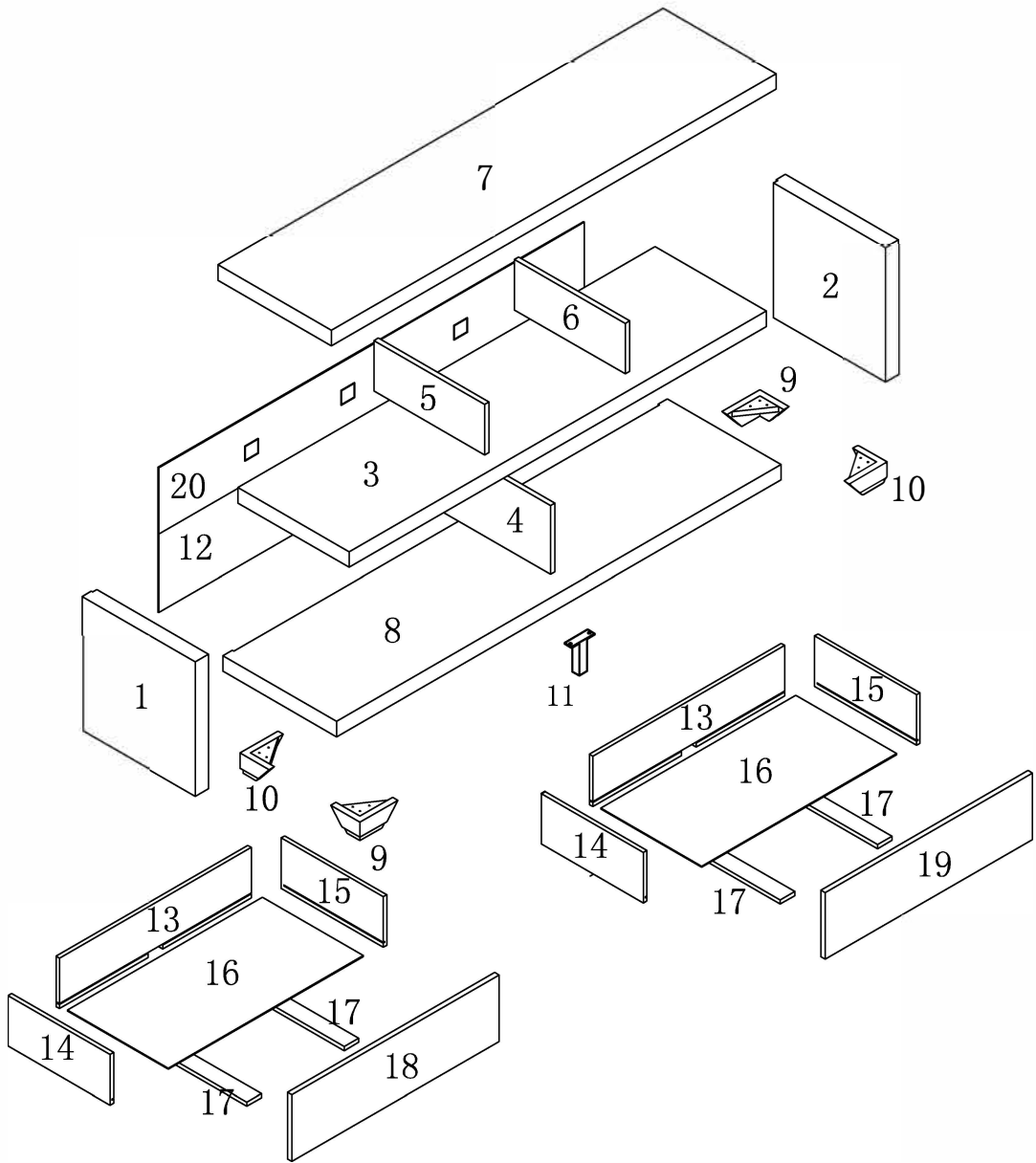





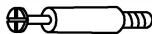

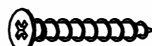

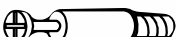

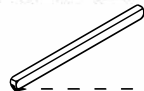
PARTS IDENTIFICATION

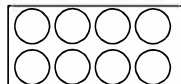

(1)	1pc	(7)	1pc	(13)	2pcs
(2)	1pc	(8)	1pc	(14)	2pcs
(3)	1pc	(9)	2pcs	(15)	2pcs
(4)	1pc	(10)	2pcs	(16)	2pcs
(5)	1pc	(11)	1pc	(17)	4pcs
(6)	1pc	(12)	1pc	(18)	1pc
				(19)	1pc

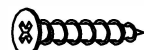
HARDWARE IDENTIFICATION

A		L29	14pcs
B		ϕ 15	14pcs
C		ϕ 7 x 58	10pcs
D		ϕ 4 x 35	12pcs
E		Z1016	38pcs
F		ϕ 4 x 30	8pcs
G		L20	8pcs
H		ϕ	8pcs
I		256MM	2pcs
J		ϕ 4 x 20	4pcs
K		ϕ 18	8pcs
L		ϕ 8 x 25	24pcs
M		ϕ 6 x 30	8pcs
N		ϕ 4 x 16	2pcs
O		80 x 25 x 68	1pc
P		ϕ 4 x 25	8pcs
Q		Pour coller la rondelle au trou de connexion / To firmly secure the cover to the connecting hole	1pc

ASSEMBLY INSTRUCTIONS

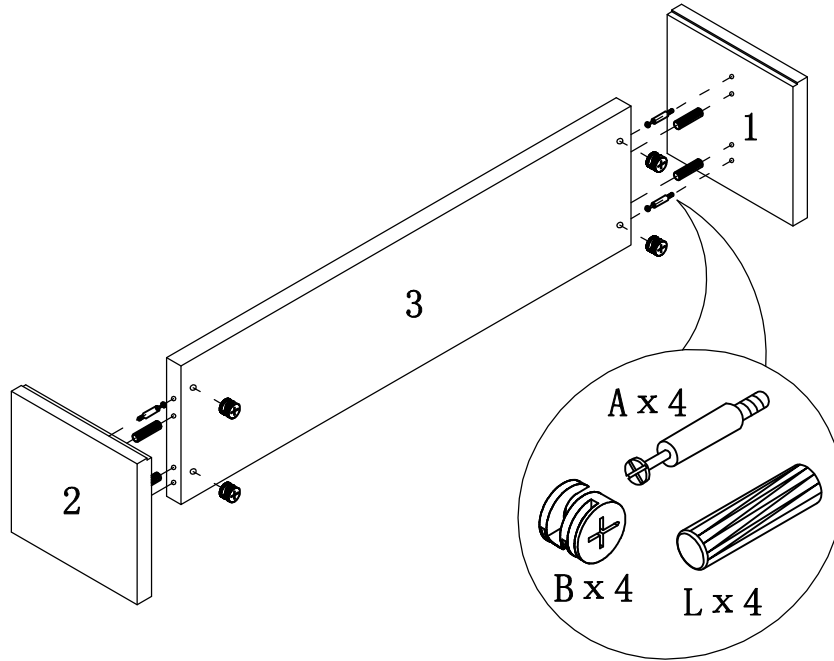

STEP 1

STEP 2

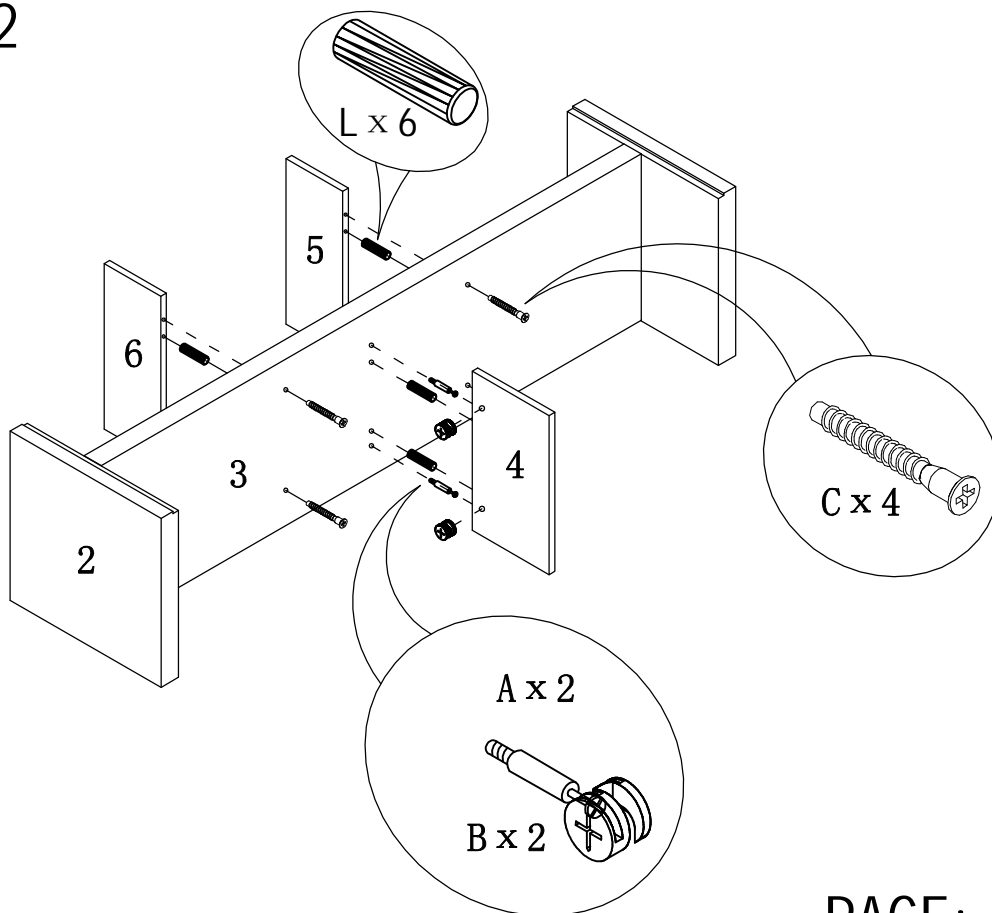

ASSEMBLY INSTRUCTIONS

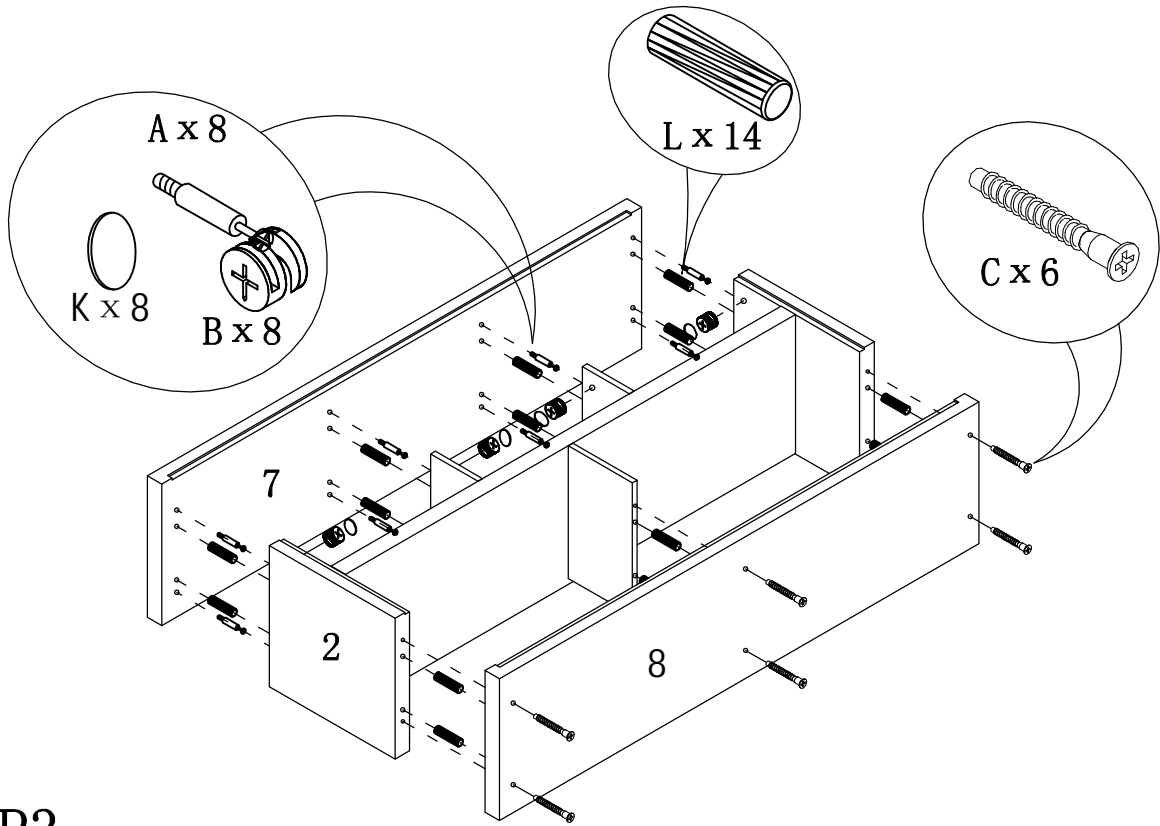

STEP 3

STEP 4

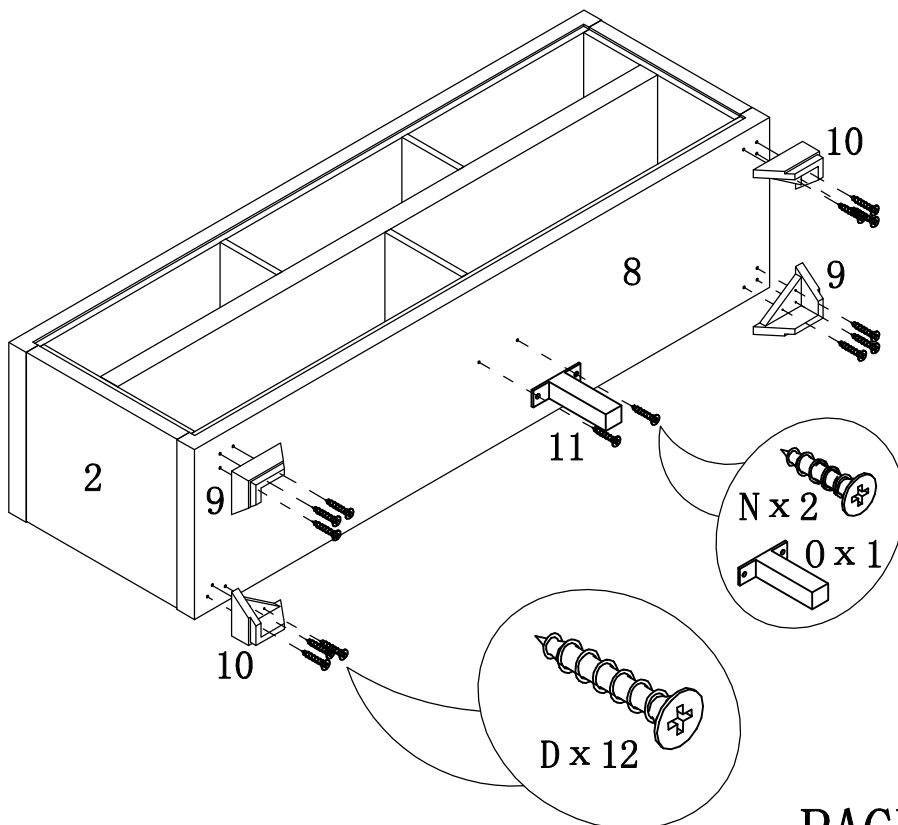

ASSEMBLY INSTRUCTIONS

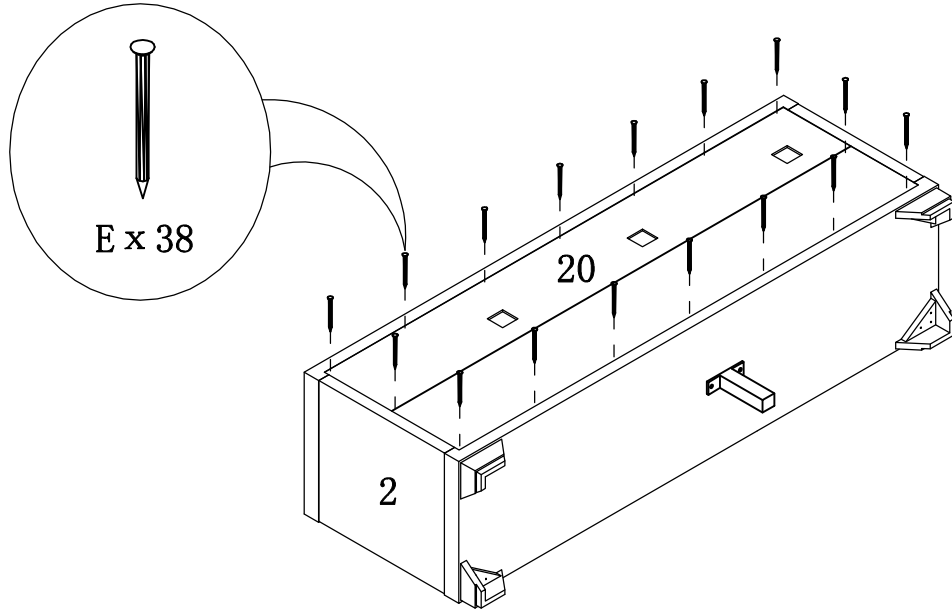

STEP5

STEP6

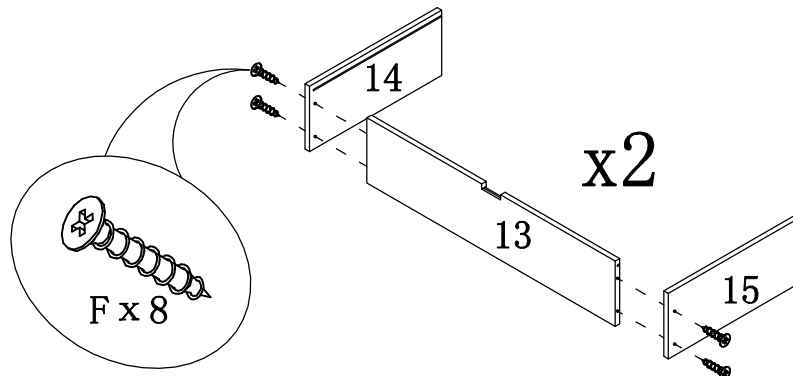

STEP7

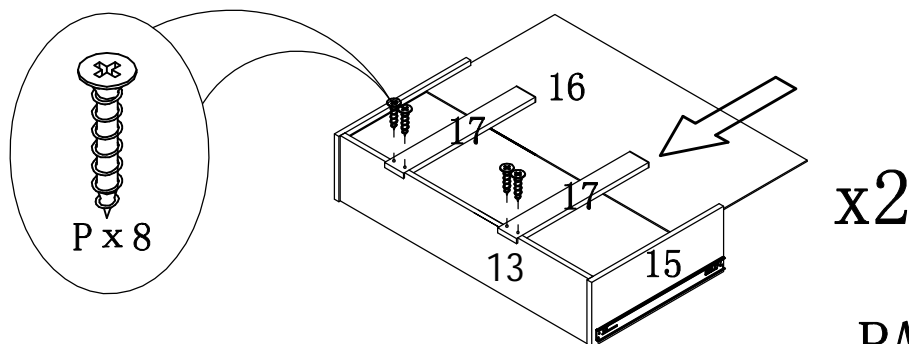

ASSEMBLY INSTRUCTIONS

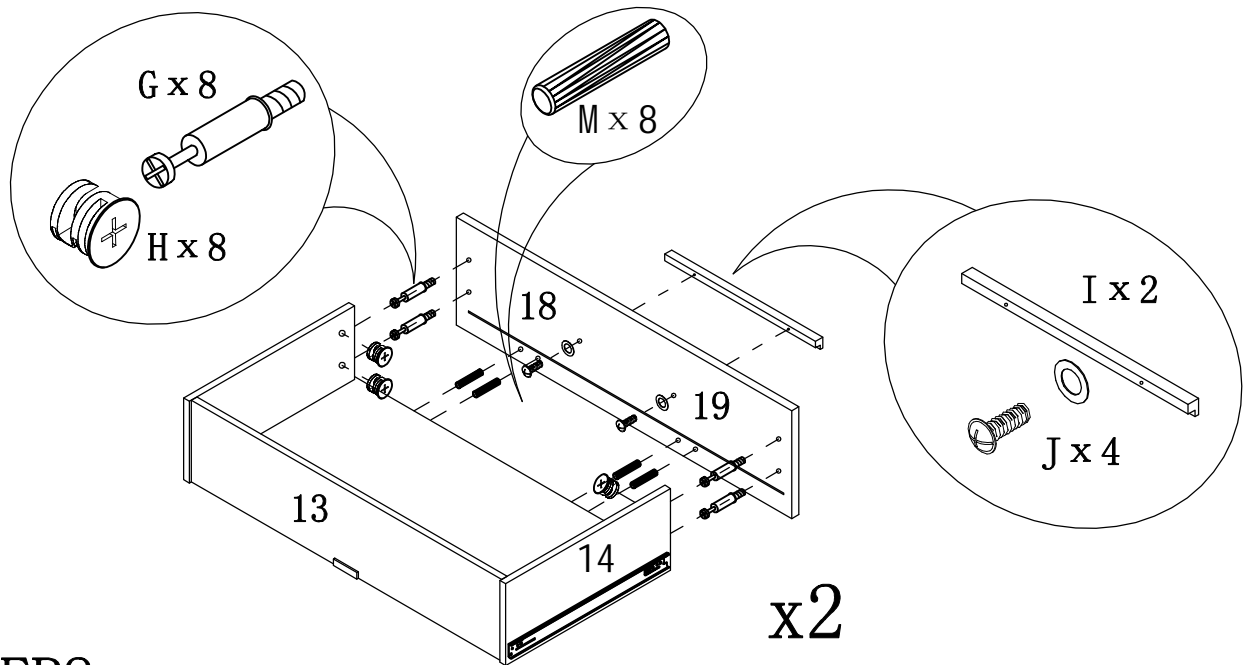

STEP8

STEP9

