





- **Antes de iniciar a montagem, verifique se você recebeu todos os componentes e peças do produto.**
- Before starting assembly, make sure you have received all the components and parts for the product.
- Antes de comenzar el montaje, asegúrese de haber recibido todos los componentes y piezas del producto.

- **Para montagem, sugerimos contratação de um profissional.**
- For assembly, we suggest hiring a professional.
- Para el montaje, sugerimos contratar a un profesional.

INSTRUÇÕES DE MONTAGEM ASSEMBLY INSTRUCTIONS INSTRUCCIONES DE MONTAJE



Pessoas necessárias.
Necessary people.
Gente necesaria.



Grau de dificuldade - alto.
Difficult level - high.
Nível de dificultad - alto.



Evitar batidas e objetos cortantes.
Avoid bumps and sharp objects.
Evitar golpes y objetos afilados.



Pano levemente umedecido com água, seguido de pano seco.
Cloth slightly dampened with water, followed by a dry cloth.
Paño ligeramente humedecido con agua, seguido de un paño seco.

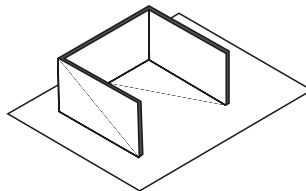

Deve-se fazer a montagem do módulo em cima de uma superfície macia. **Dica:** Usar a caixa.
The module must be mounted on a soft surface.
Tip: Use the box.
El módulo debe montarse sobre una superficie blanda. **Consejo:** Usa la caja.



Não utilizar químicos ou abrasivos na limpeza.
Do not use chemicals or abrasives for cleaning.
No utilice productos químicos o abrasivos

Ferramentas Necessárias required tools / herramientas requeridas (não fornecidas / not provided / no provisto)



Fita métrica
Measuring tape
Cinta métrica



Chave Philips
Philips Screwdriver
Destornillador Philips



Chave Philips Pequena
Philips Screwdriver Small
Destornillador Philips Pequeño



Martelo
Hammer
Martillo



Furadeira
Power Drill
Taladro



ø 6mm e 10mm
ø 6mm and 10mm
ø 6mm y 10mm

Componentes do Módulo

Module Components

Componentes del Módulo



A - Cavilha 8x30 (12x)
 A - Peg 8x30 (12x)
 A - Espiga 8x30 (12x)

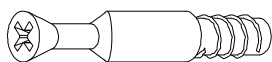

B - Minifix (6x)
 B - Minifix (6x)
 B - Minifix (6x)

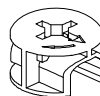

C - Tambor (6x)
 C - Drum (6x)
 C - Tambor (6x)

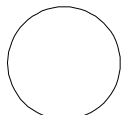

D - Tapa Furo Adesivo (6x)
 D - Self Adhesive Cap Cover (6x)
 D - Tapa Aguejo Autoadhesivos (6x)



F11 - Parafuso Euro Ø6x10 (16x)
 F11 - Screw Euro Ø6x10 (16x)
 F11 - Tornilo Euro Ø6x10 (16x)

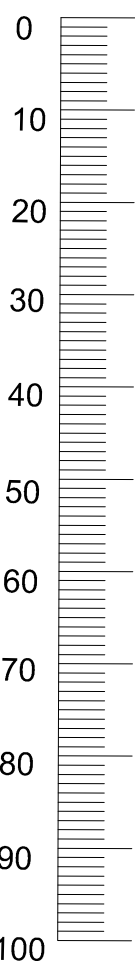

medidas em mm / measures in mm / medidas en mm

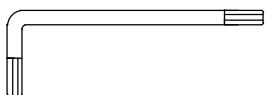

R1 - Chave Allen (1x)
 R1 - Key Allen (1x)
 R1 - Llave Allen (1x)



F4 - Parafuso Travessa Ø4x25 (8x)
 F4 - Screw Platter Ø4x25 (8x)
 F4 - Tornilo Plato Ø4x25 (8x)



F9 - Parafuso Euro Ø5x35 (6x)
 F9 - Screw Euro Ø5x35 (6x)
 F9 - Tornilo Euro Ø5x35 (6x)



F6 - Parafuso Pé Ø4x40 (8x)
 F6 - Screw Foot Ø4x40 (8x)
 F6 - Tornilo Pie Ø4x40 (8x)

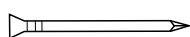

E - Prego 10x10 (22x)
 E - Nail 10x10 (22x)
 E - Clavo 10x10 (22x)

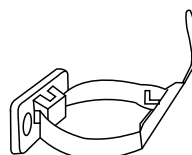

Z - Kit Anti Tombamento (1x)
 Z - Kit Anti tipping (1x)
 Z - Kit Antivuelco (1x)

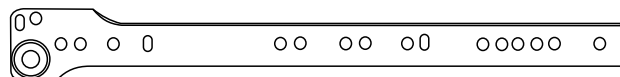

I2 - Corrediça Módulo (8x)
 I2 - Module Slide (8x)
 I2 - Corrediza Módulo (8x)

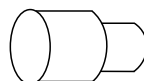

L - Suporte para prateleira (4x)
 L - Shelf support (4x)
 L - Soporte de estantería (4x)



F3 - Parafuso da dobradiça Ø4x16 (8x)
 F3 - hinge screw Ø4x16 (8x)
 F3 - Tornillo de bisagra Ø4x16 (8x)

Componentes do Módulo

Module Components

Componentes del Módulo

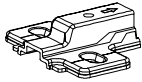

J2 - Calço de dobradiça (2x)
J2 - Hinge shim (2x)
J2 - Cuña de bisagra (2x)

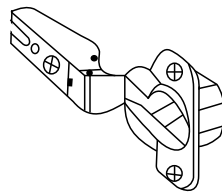

K1 - Dobradiça (2x)
K1 - Hinge (2x)
K1 - Bisagra (2x)

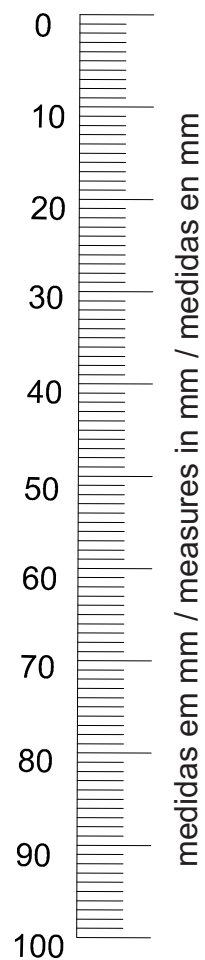

Componentes da Gaveta

Drawer Components

Componentes del Cajón

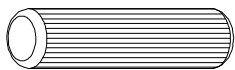

A - Cavilha 8x30 (16x)
 A - Peg 8x30 (16x)
 A - Espiga 8x30 (16x)

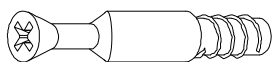

B - Minifix (8x)
 B - Minifix (8x)
 B - Minifix (8x)

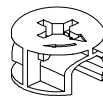

C - Tambor (8x)
 C - Drum (8x)
 C - Tambor (8x)

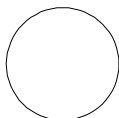

D - Tapa Furo Adesivo (8x)
 D - Self Adhesive Cap Cover (8x)
 D - Tapa Aguejo Autoadhesivos (8x)



F2 - Parafuso 4x14 (16x)
 F2 - Screw 4x14 (16x)
 F2 - Tornilo 4x14 (16x)



F9 - Parafuso Euro Ø5x35 (8x)
 F9 - Screw Euro Ø5x35 (8x)
 F9 - Tornilo Euro Ø5x35 (8x)

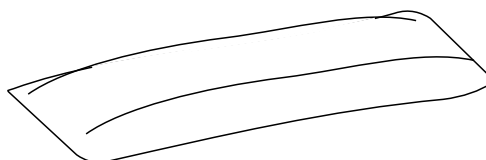

G - Cola (2x)
 G - Glue (2x)
 G - Pegamento (2x)

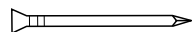

E - Pregão 10x10 (28x)
 E - Nail 10x10 (28x)
 E - Clavo 10x10 (28x)

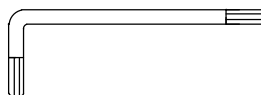

R1 - Chave Allen (1x)
 R1 - Key Allen (1x)
 R1 - Llave Allen (1x)



I 2 - Corrediça Gaveta (8x)
 I 2 - Slide Drawer (8x)
 I 2 - Corrediza Cajón (8x)

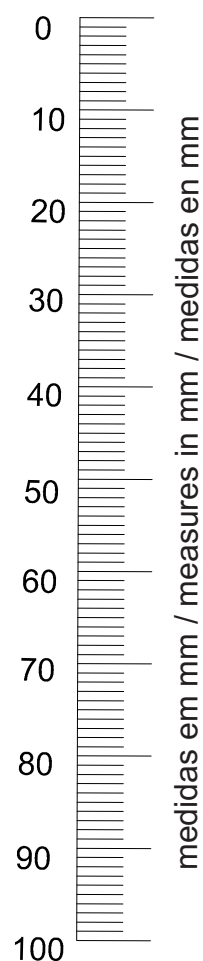

Partes do módulo

Module Parts

Partes del módulo

- 1** Base Superior (1x)
Top Base (1x) / Base Superior (1x)
- 2** Base Inferior (1x)
Bottom Base (1x) / Base Inferior (1x)
- 3** Lateral Direita (1x)
Right Side (1x) / Lado Derecho (1x)
- 4** Lateral Esquerda (1x)
Left Side (1x) / Lado Izquierdo (1x)
- 5** Costa (2x)
Coast (2x) / Costa (2x)
- 11** Porta Direita (1x)
Right Door (1x) / Puerta Derecha (1x)
- 9** Divisória (1x)
Partition (1x) / División (1x)
- 14** Prateleira (1x)
Shelf (1x) / Estante (1x)
- 100** Pés (4x)
Foot (4x) / Pies (4x)
- 101** Travessas (2x)
Traviesas (2x) / Sleepers (2x)
- 103** Conector de Fundo (1x)
Bottom Connector (1x) / Conector Inferior (1x)

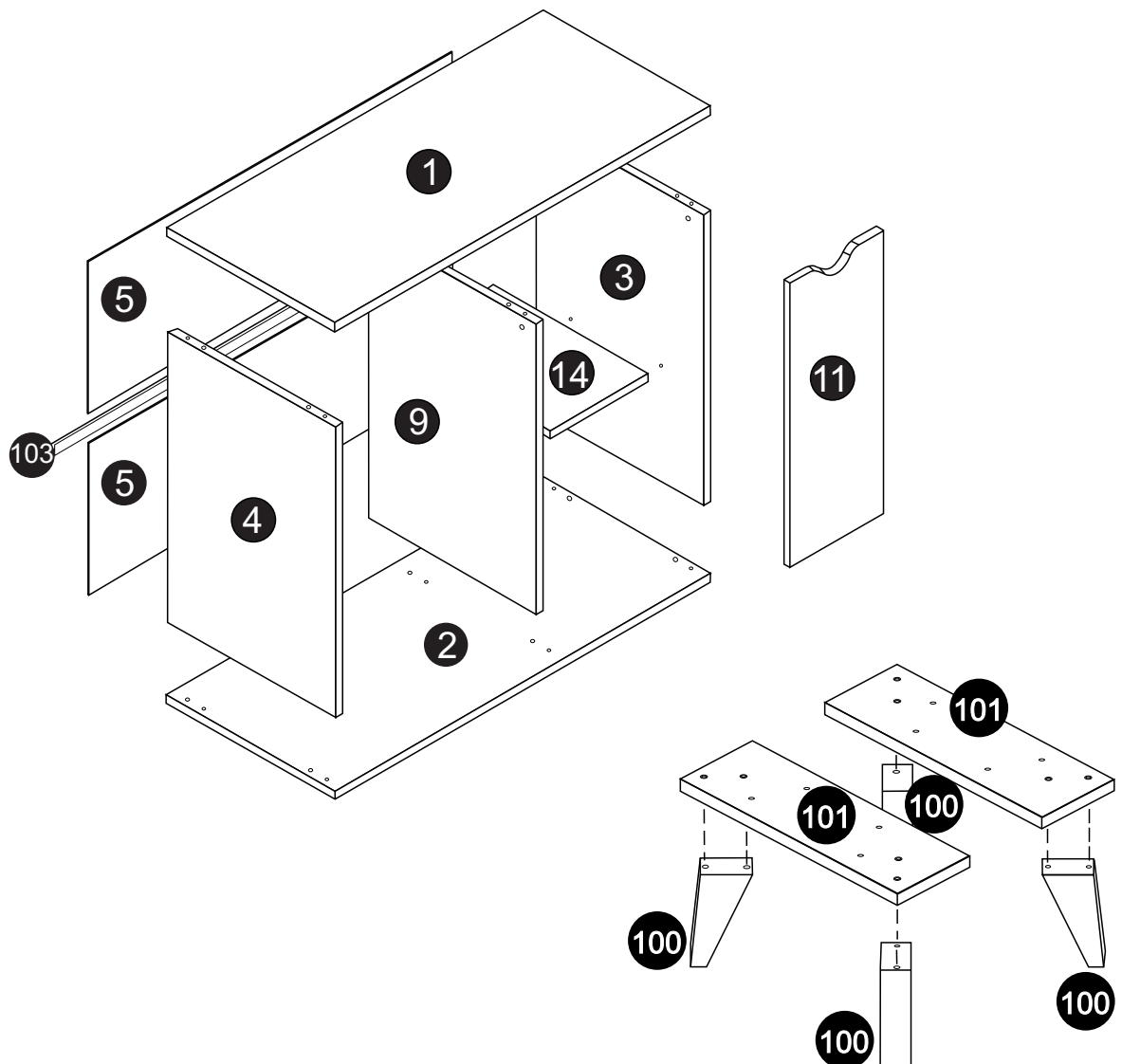

Partes da Gaveta

Drawer Parts

Partes del Cajón

50 Lateral Gaveta Esq. (4x)
Left Side Drawer (4x) / Cajón Lado Izquierdo (4x)

51 Lateral Gaveta Dir. (4x)
Right Side Drawer (4x) / Cajón Lado Derecho (4x)

52 Fundo de Gaveta (4x)
Drawer Bottom (4x) / Fondo Del Cajón (4x)

53 Base de Gaveta (4x)
Drawer Base (4x) / Base Del Cajón (4x)

54 Frente de Gaveta (4x)
Drawer Front (4x) / Frente Del Cajón (4x)

04 Unidades

04 Units

04 Unidades

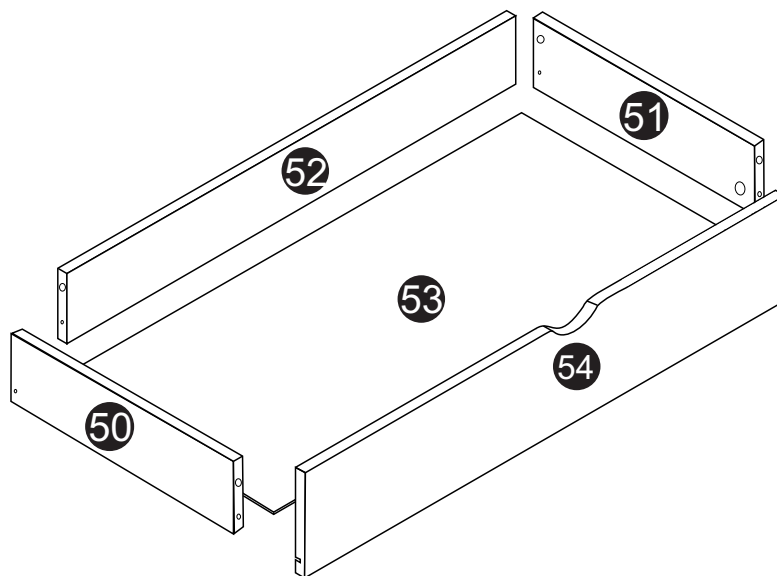

Pré montagem do módulo

Module pre-assembly

Premontaje del módulo

01

Lateral Esquerda
Left Side
Lado Izquierdo

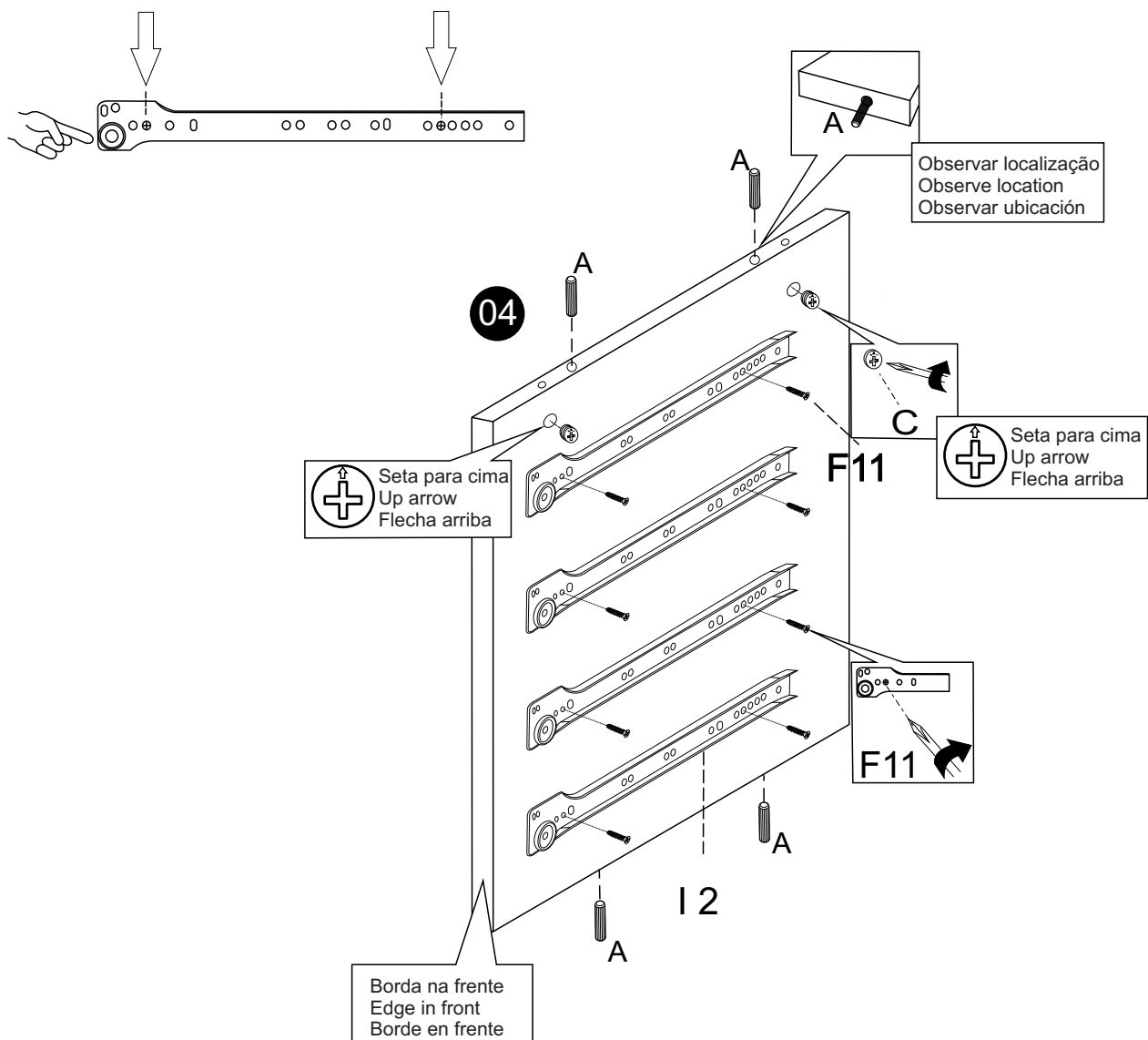

C		2 PÇS
A		4 PÇS
I 2		4 PÇS
F11		8 PÇS

03

Lateral Direita
Right Side
Lado Derecho

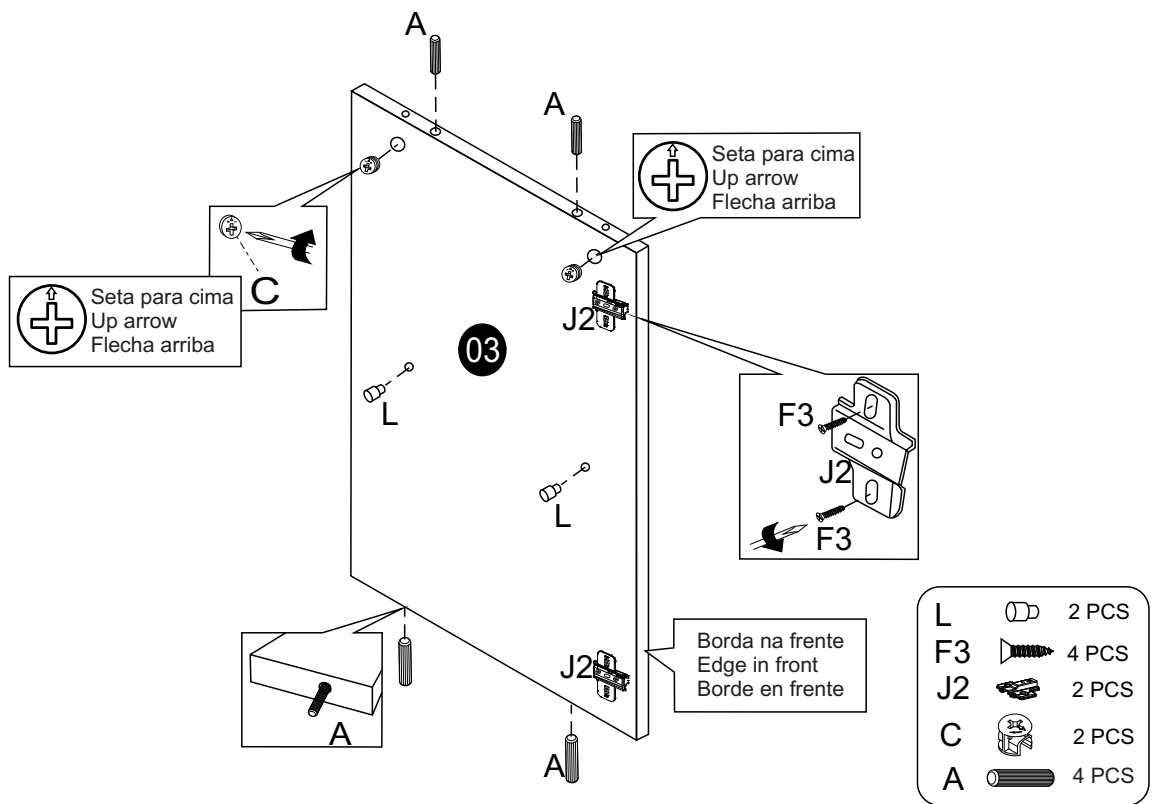

04

Base Superior
Top Base
Base Superior

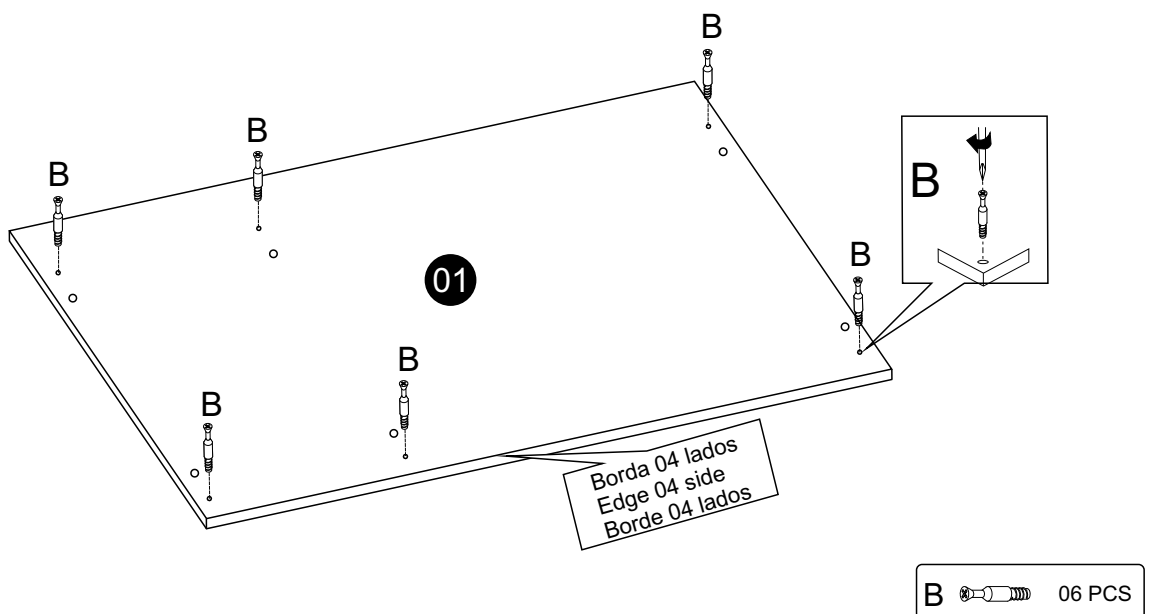

05

Base Inferior - Conferencia do desenho parte externa
Botton Base - External design conference
Base Inferior - Conferencia de dibujo exterior

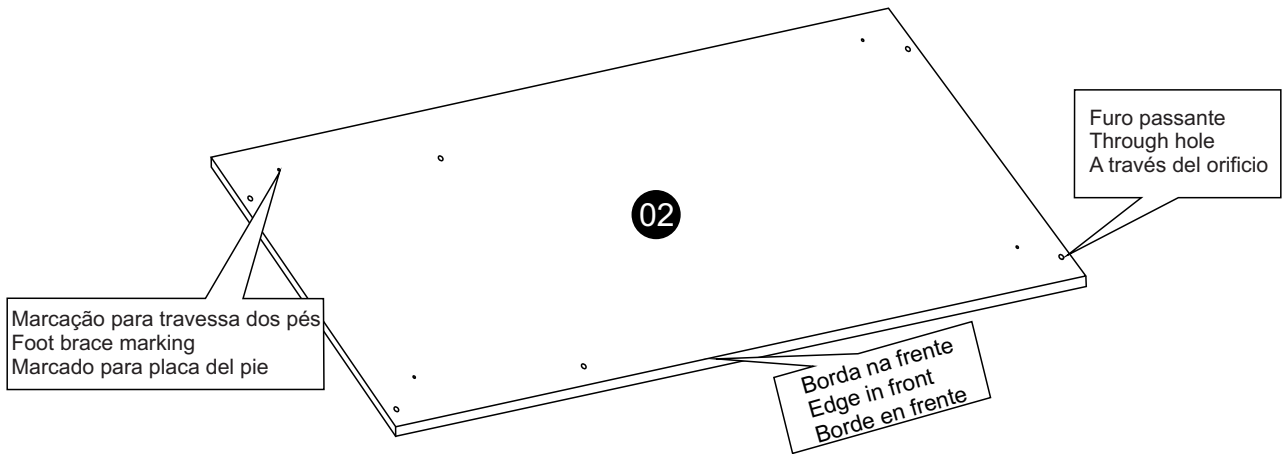

06

Base Inferior - Conferencia do desenho parte interna
Botton Base - Internal design conference
Base Inferior - Conferencia de dibujo interior

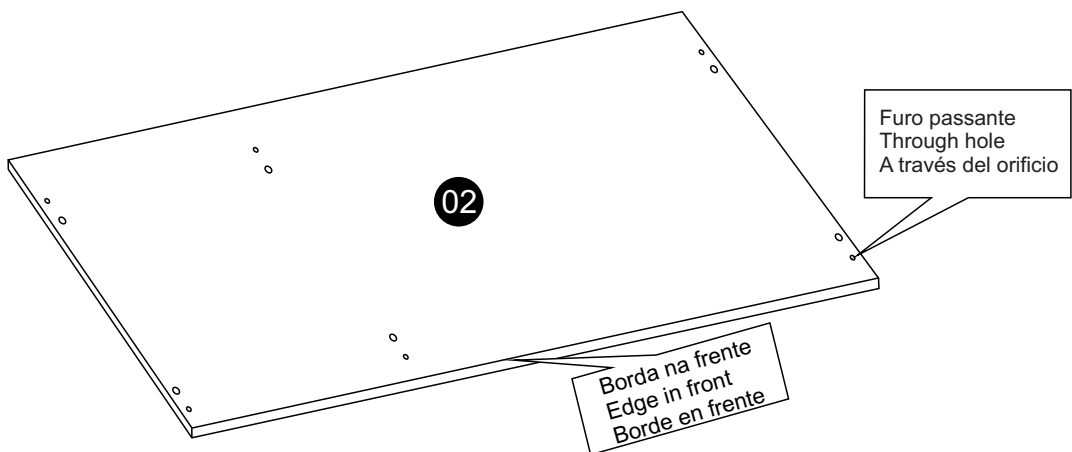

07

Costa
Coast
Costa

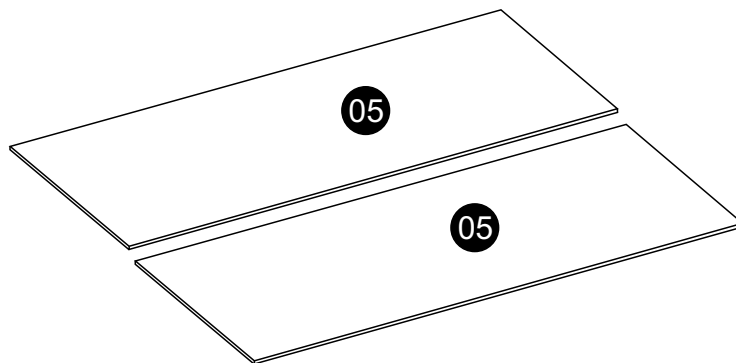

08

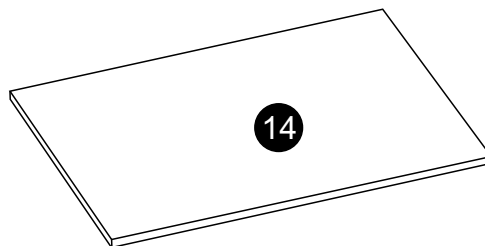

Prateleira
Shelf
Estante

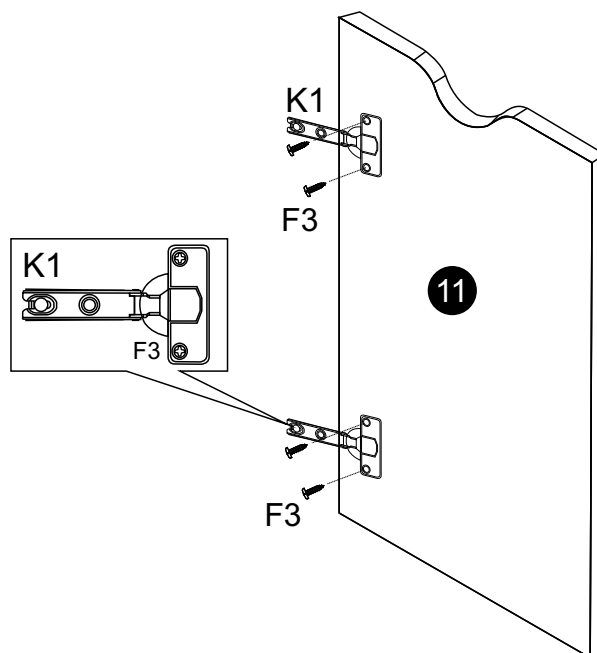

09

Porta
Door
Puerta



K1		2 PCS
F3		4 PCS

Montagem do módulo

Module assembly

Montaje del módulo

01

Base Superior + Lat. Direita

Top Base + Right Side

Base Superior + Lado Derecho

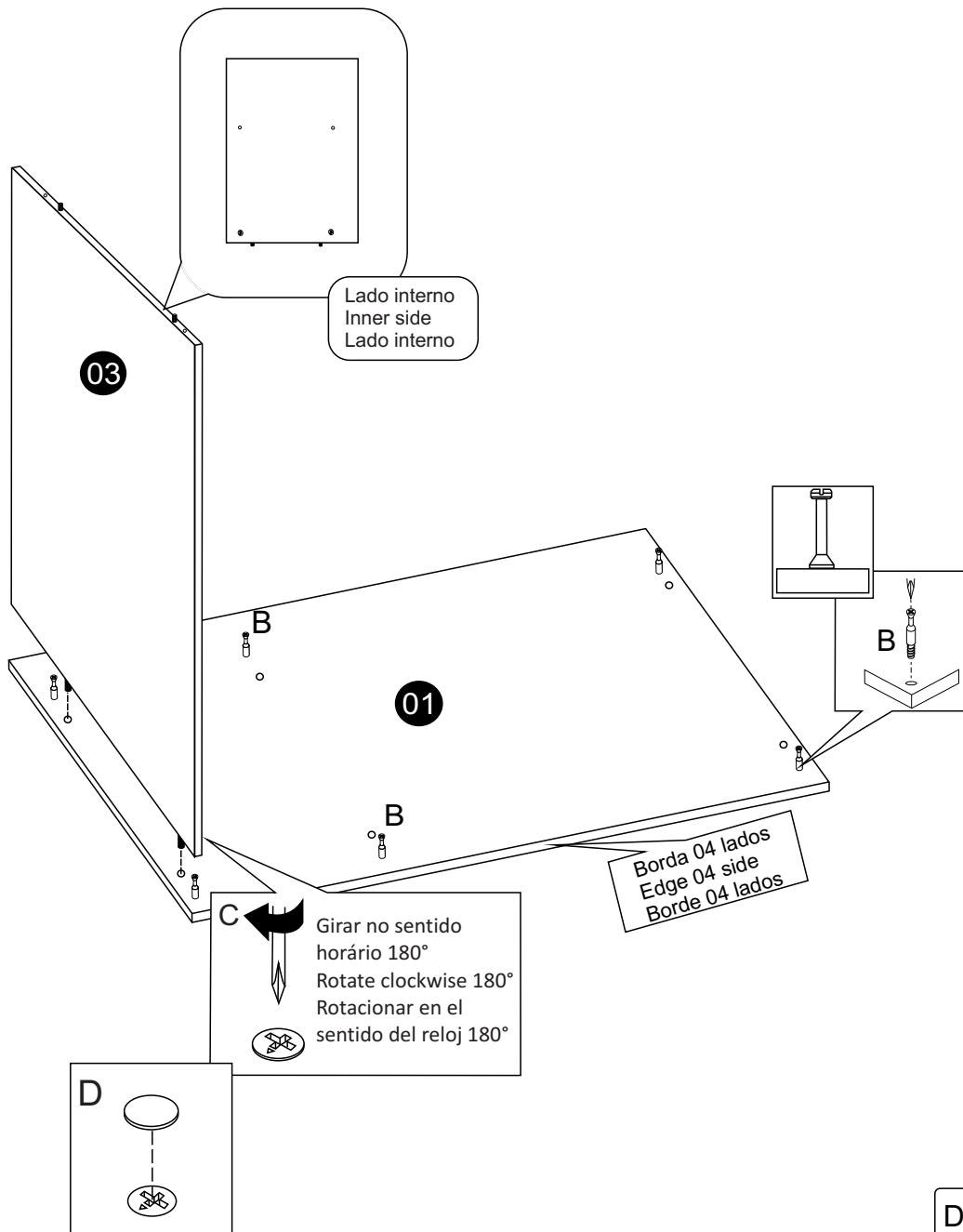

02

Base Superior + Lat. Direita + Divisória
Top Base + Right Side + Partition
Base Superior + Lado Derecho + División

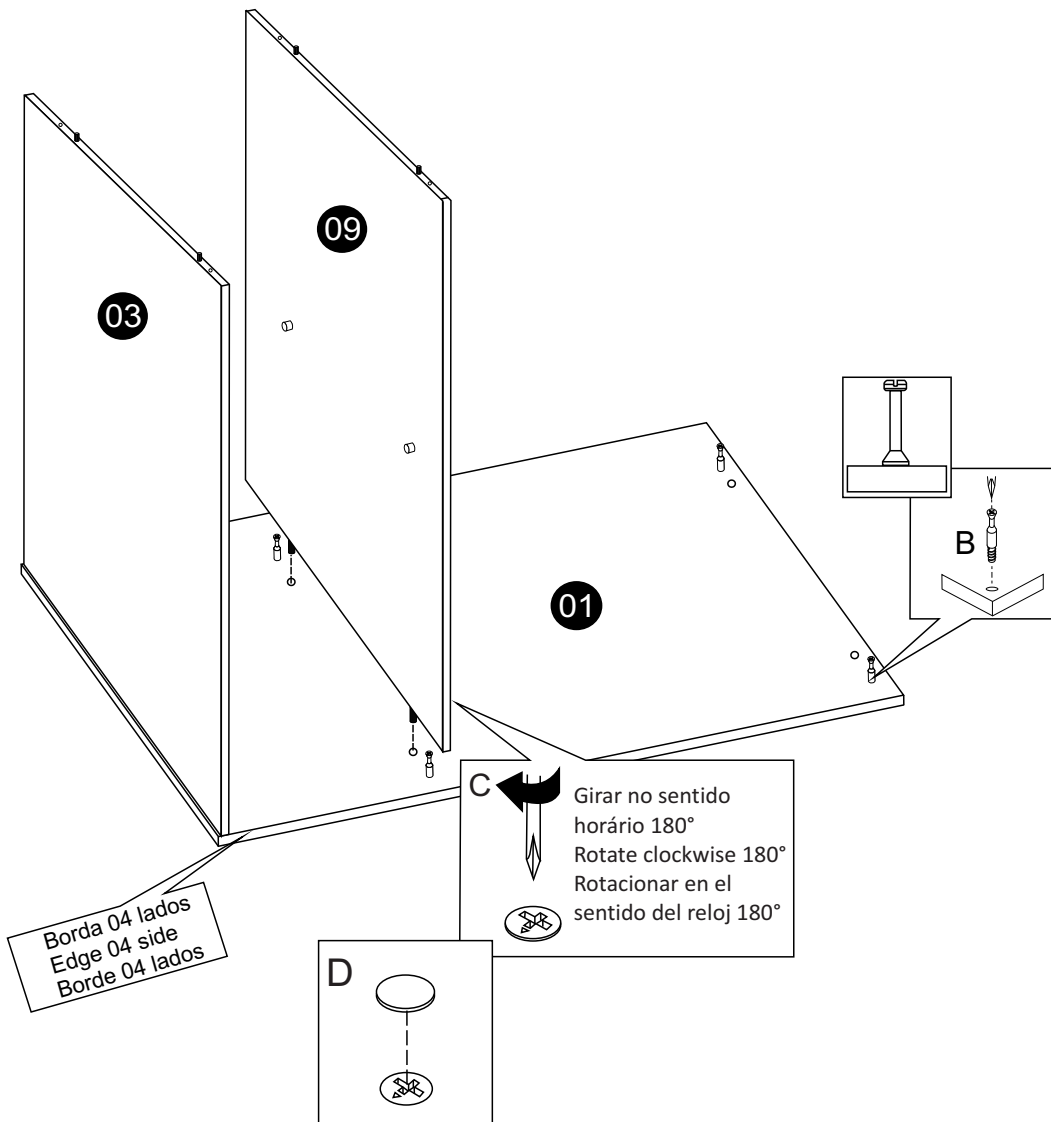

D ○ 02 PCS

04

Base Superior + Lat. Direita + Divisória + Lateral Esquerda
Top Base + Right Side + Partition + Left Side
Base Superior + Lado Derecho + División + Lado Izquierdo

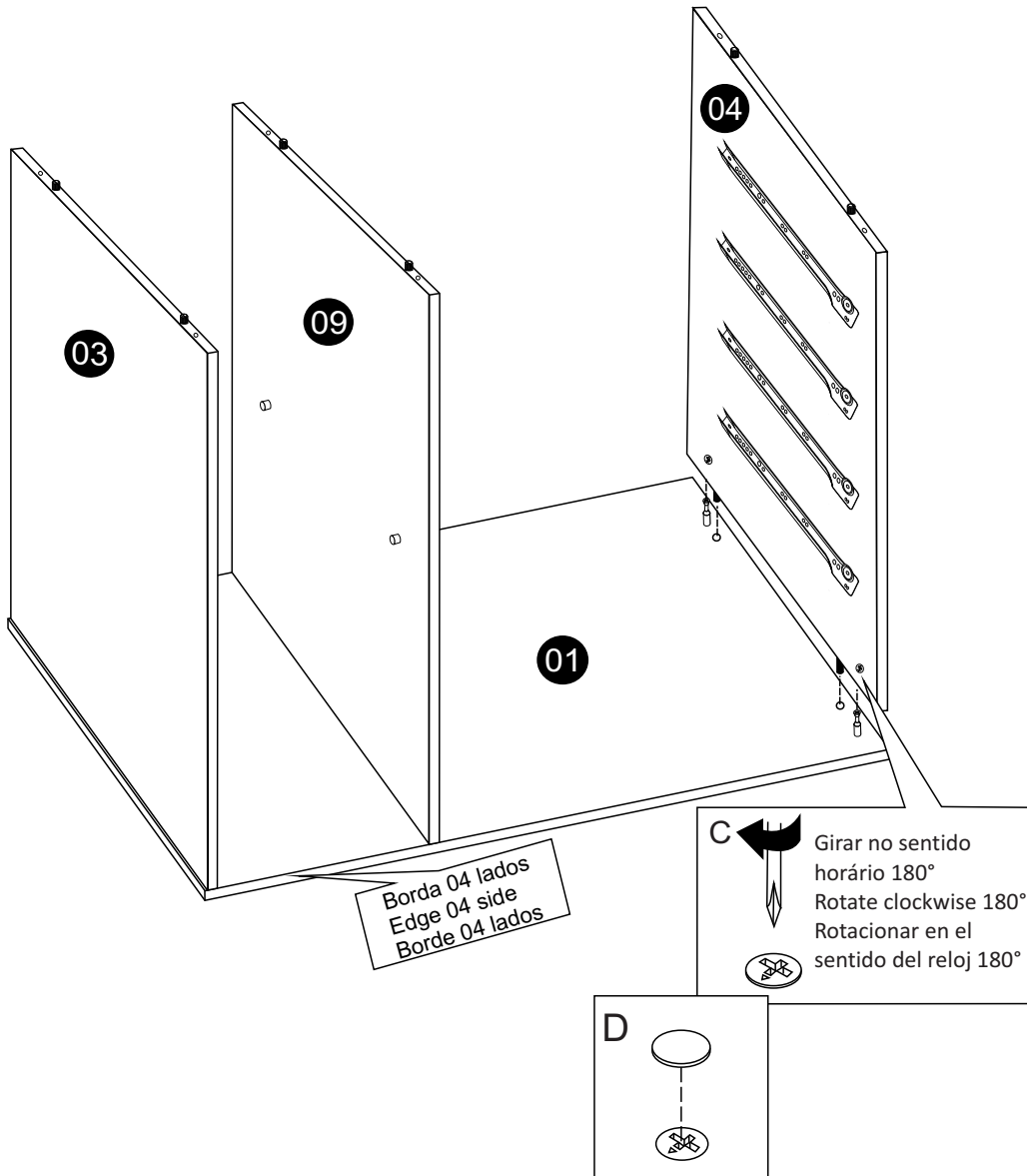

D ○ 02 PCS

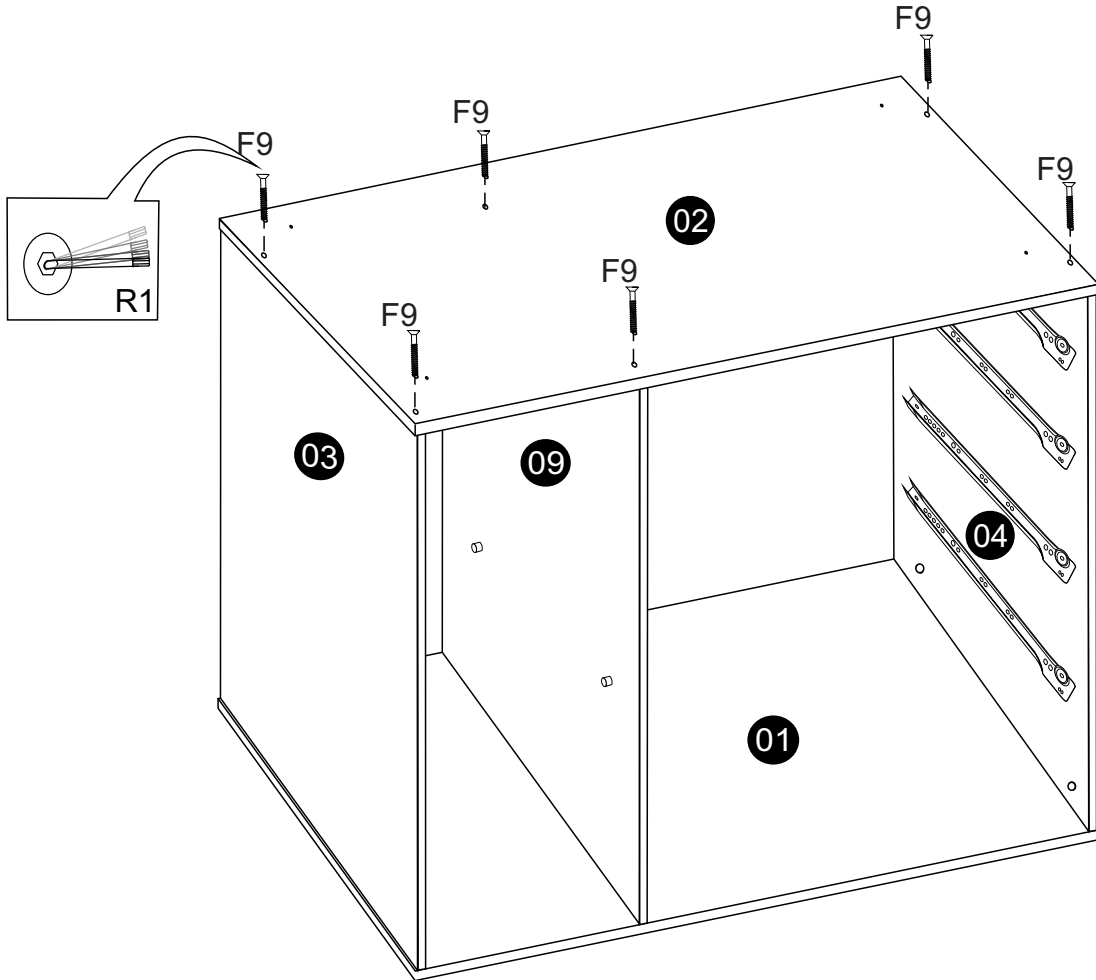

05

Base Inferior
Botton Base
Base Inferior



Utilizar a chave Allen para fixar a base inferior nas laterais.
Use the key Allen to fix the lower base on the sides.
Usa la llave Allen para fijar la base inferior a los lados.

R1 

F9  06 PCS
R1  01 PCS

06

Conector de fundo e chapinha de união
Bottom connector and union plate
Conector inferior y placa de unión

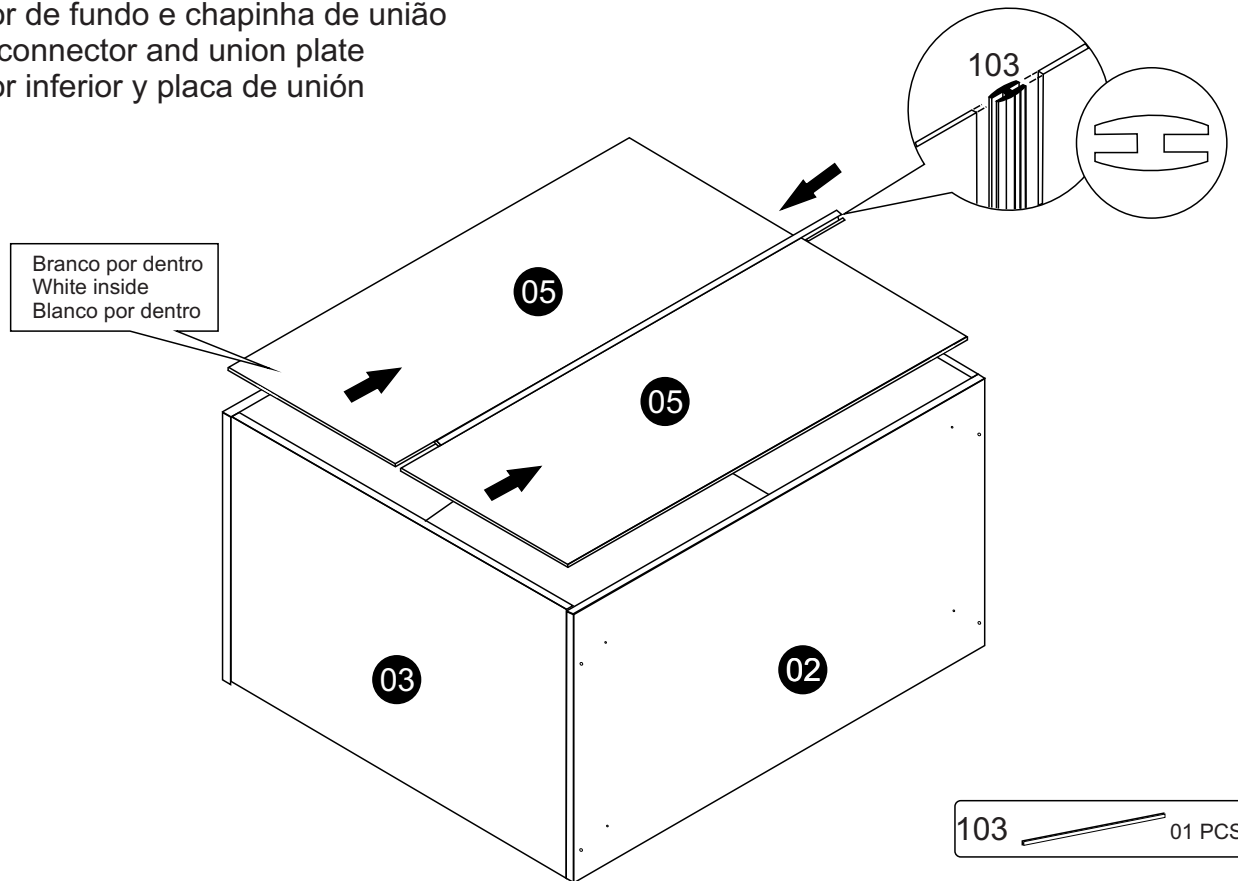

07

Conferir o esquadro da costa
Check the coast square
Revisa la plaza de la costa

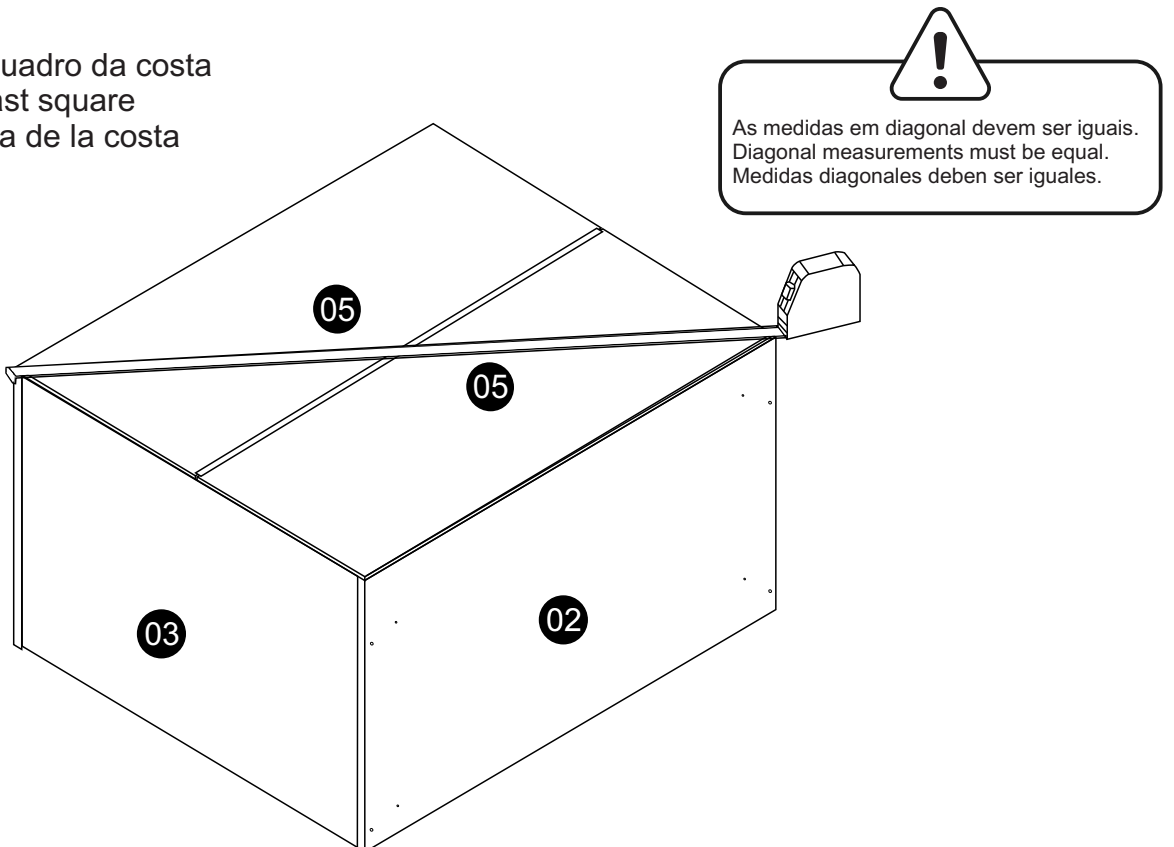

08

Montagem da costa
Mounting of coast
Montaje del costa

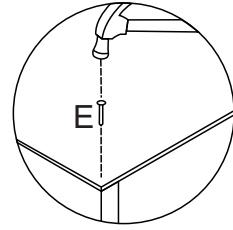
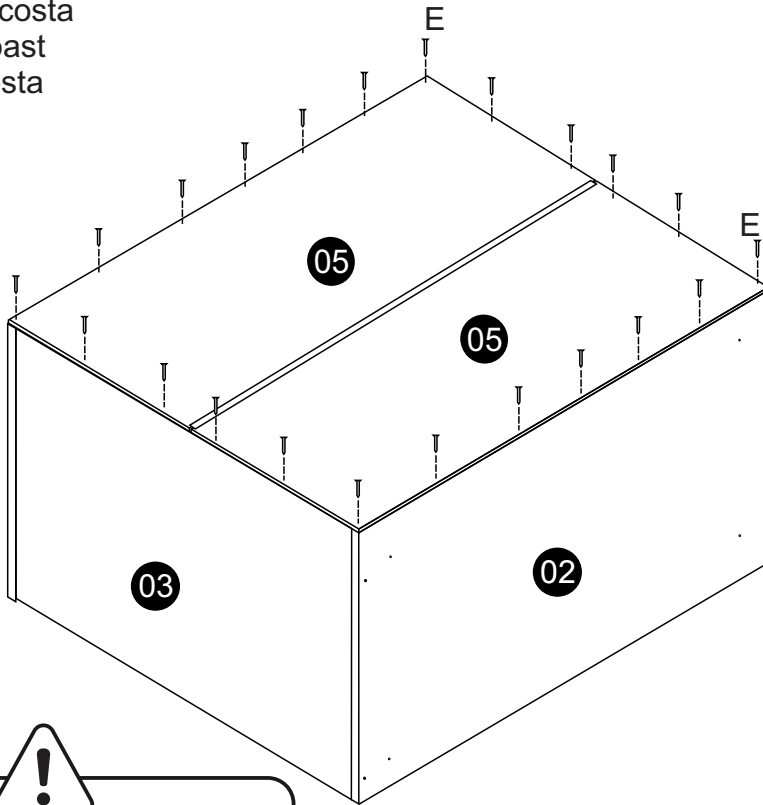

Observe a quantidade de pregos necessários.
Note the amount of nails needed.
Tenga en cuenta la cantidad de clavos necesarios.

E  22 PCS

09

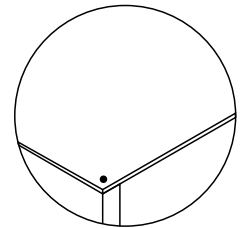
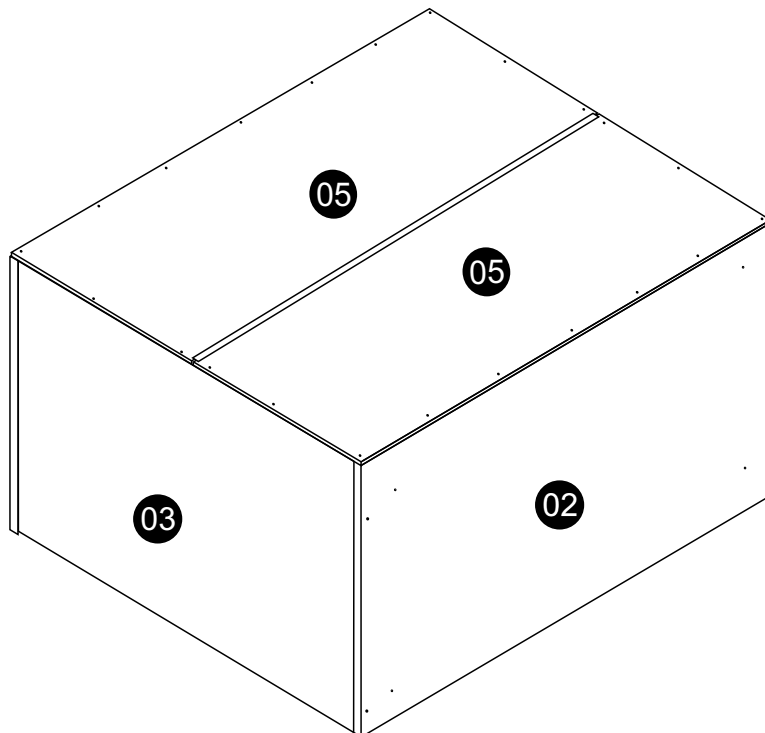

Pré montagem da gaveta

Drawer pre-assembly

Premontaje del cajón

01

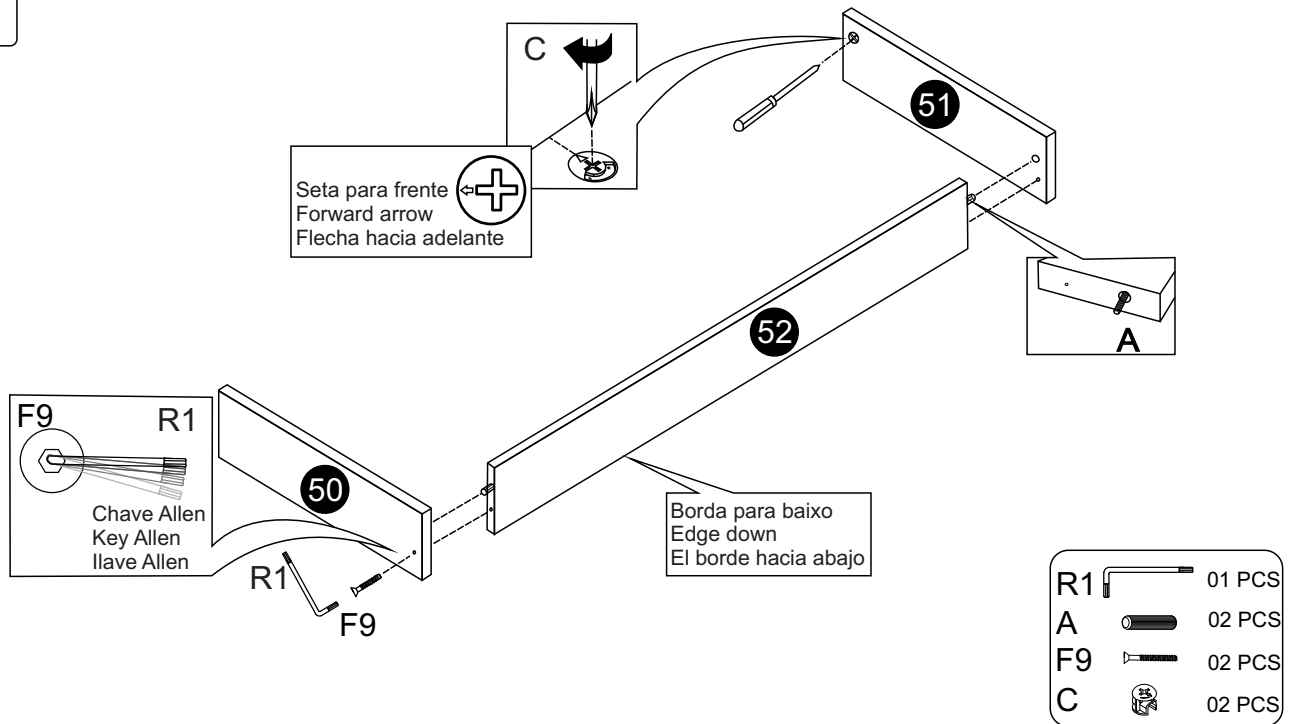

02

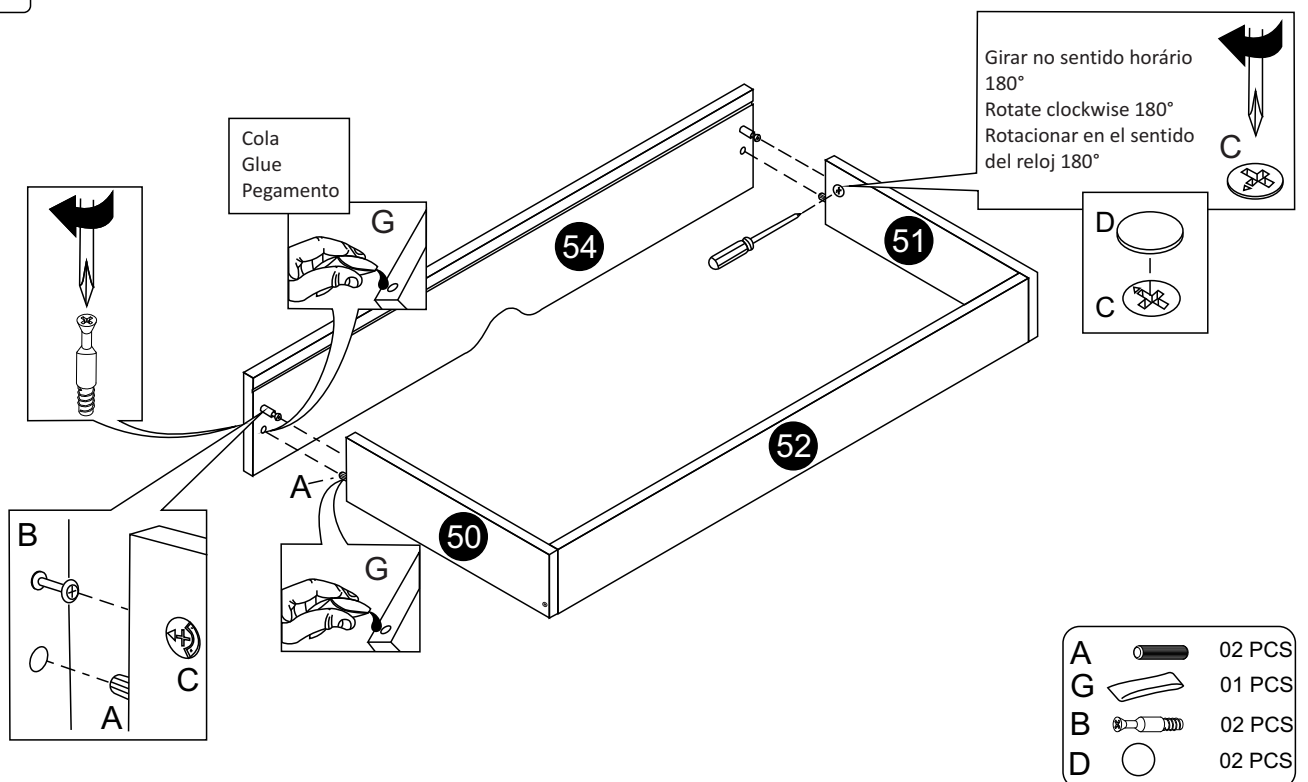

03

Aplicação de cola na frente da gaveta
Glue application on the front of the drawer
Aplicación de cola en el frente del cajón

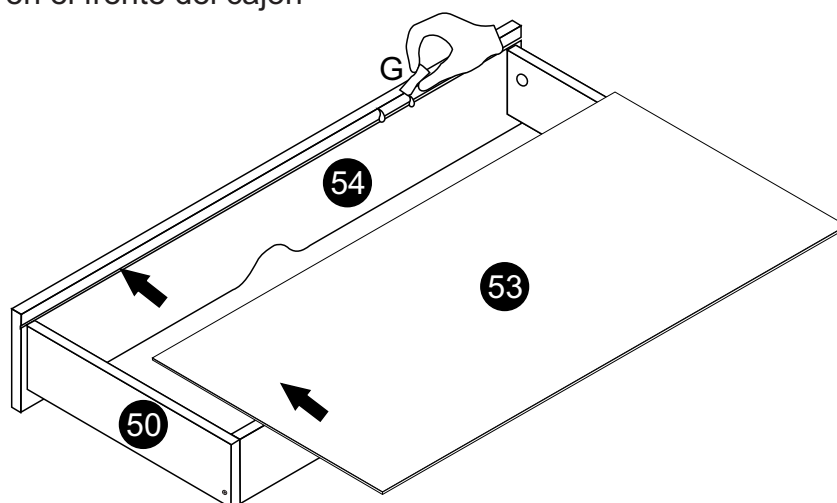

G  01 PCS

04

Conferir o esquadro da gaveta
Check the drawer square
Revisa la plaza del cajón

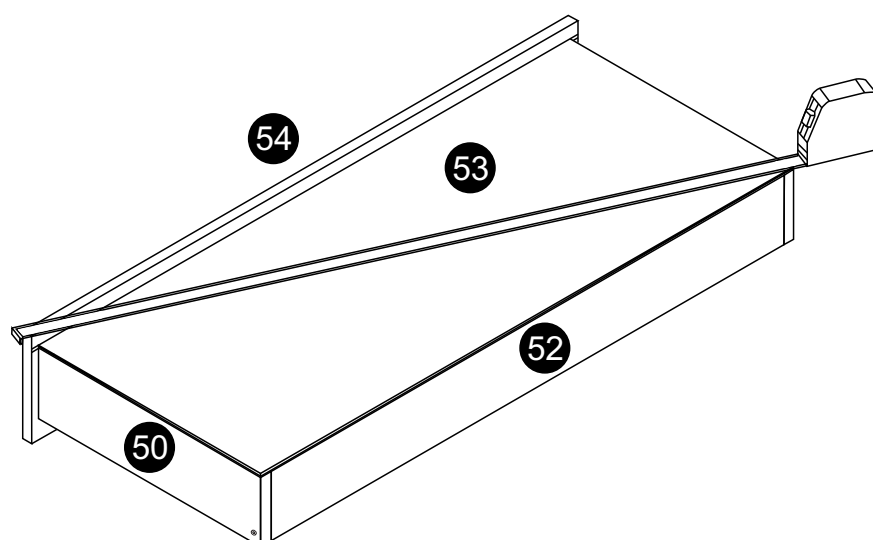

05



Observe a quantidade de pregos necessários.
 Note the amount of nails needed.
 Tenga en cuenta la cantidad de clavos necesarios.

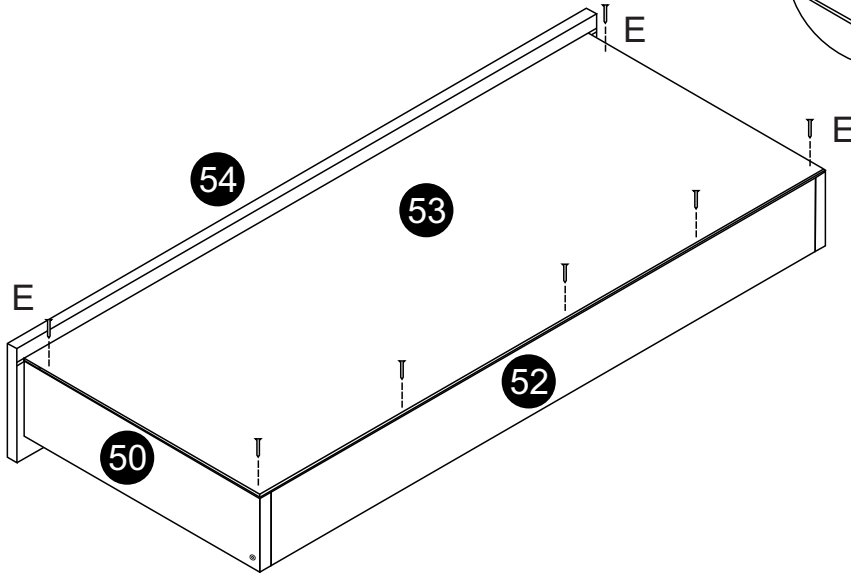
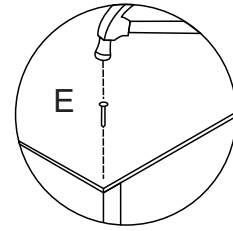

E  07 PCS

06

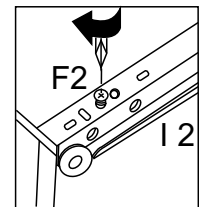
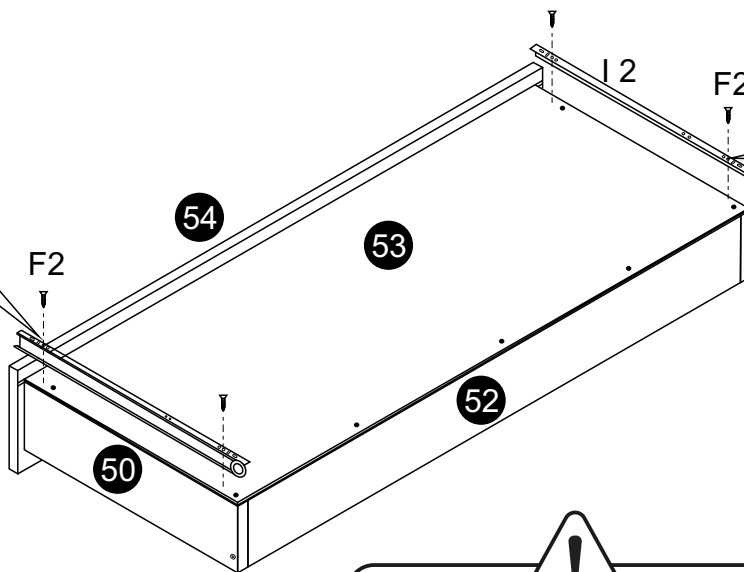
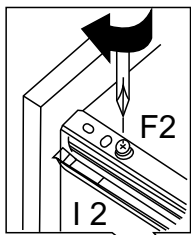

Encostar a corredeira na frente da gaveta.
 Place the slide in front of the drawer.
 Coloque la corredera frente al cajón

I2  02 PCS

F2  04 PCS

07

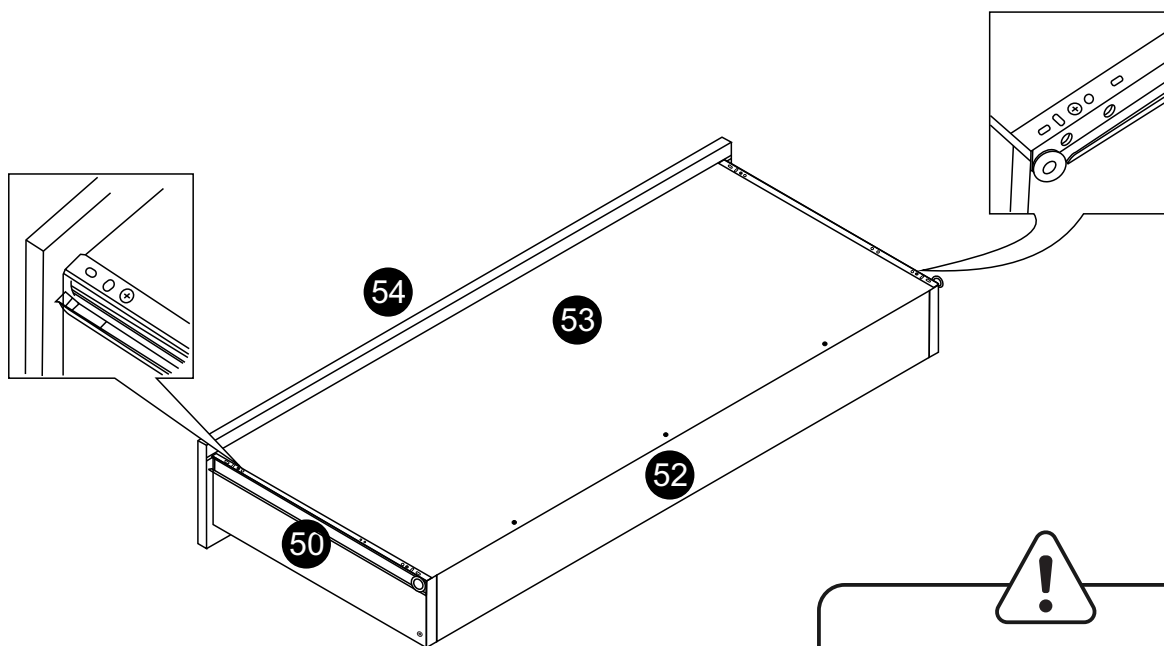

Encostar a corrediça na frente da gaveta.
Place the slide in front of the drawer.
Coloque la corredera frente al cajón

08

Kit Anti tombamento - Seguir o manual do produto
Kit Anti tipping - Follow the product manual
Kit Antivuelco - Siga el manual del producto

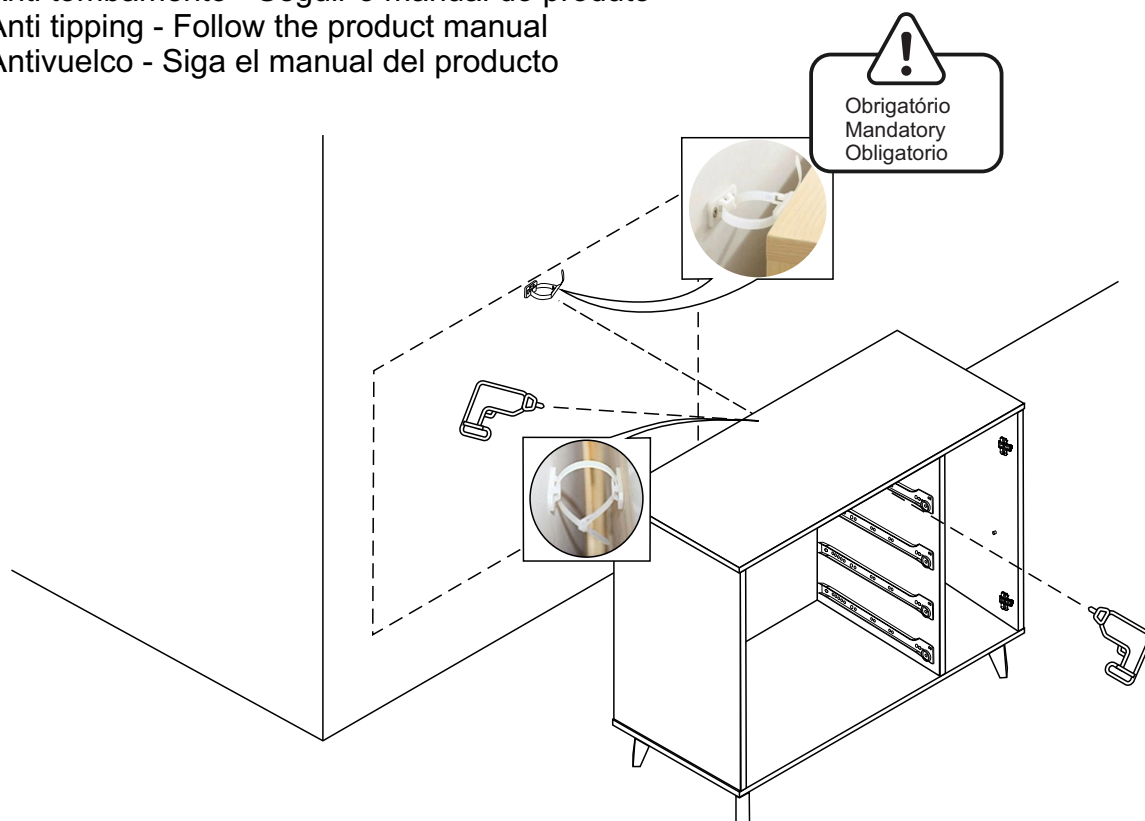

Obrigatório
Mandatory
Obligatorio

Z  01 PCS

09

Prateleira
Shelf
Estante

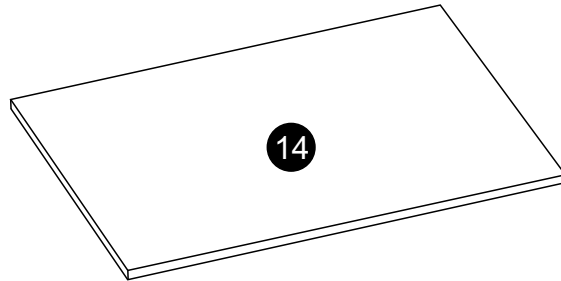

10

Instalação da prateleira
Shelf installation
Instalación de estantes

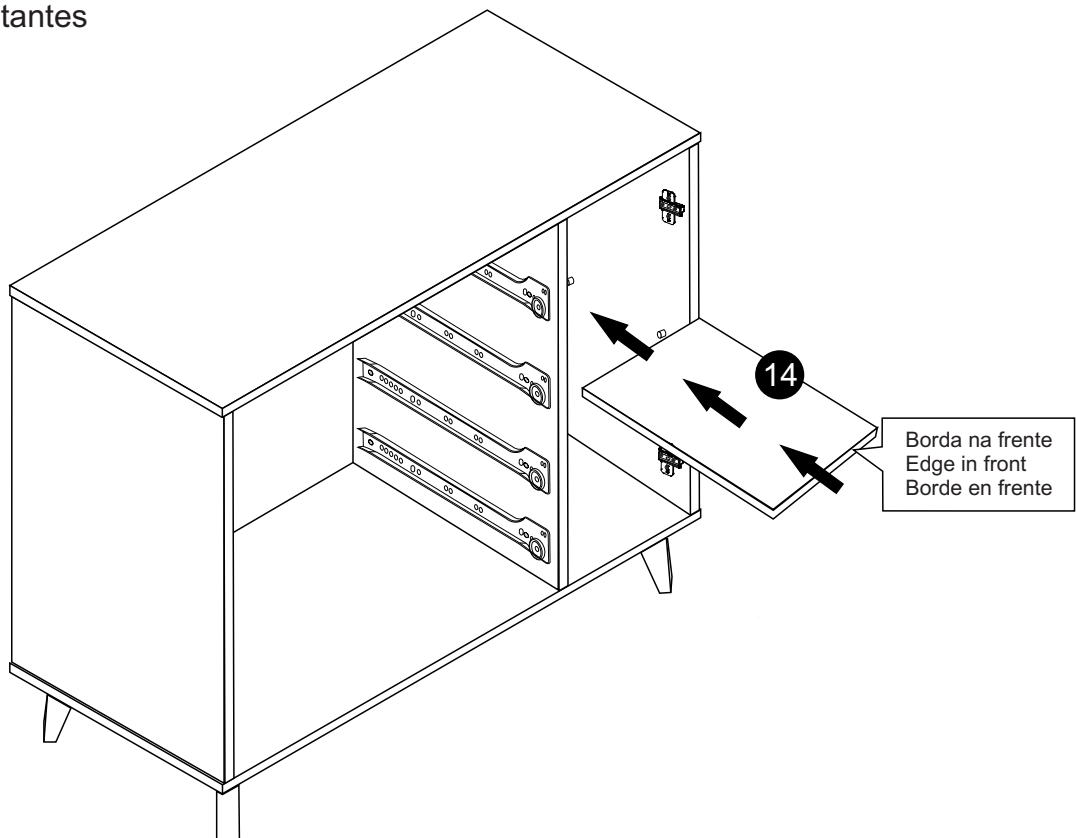

12

Porta
Door
Puerta

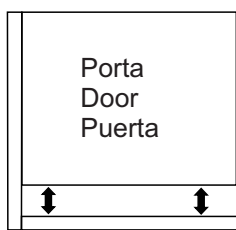
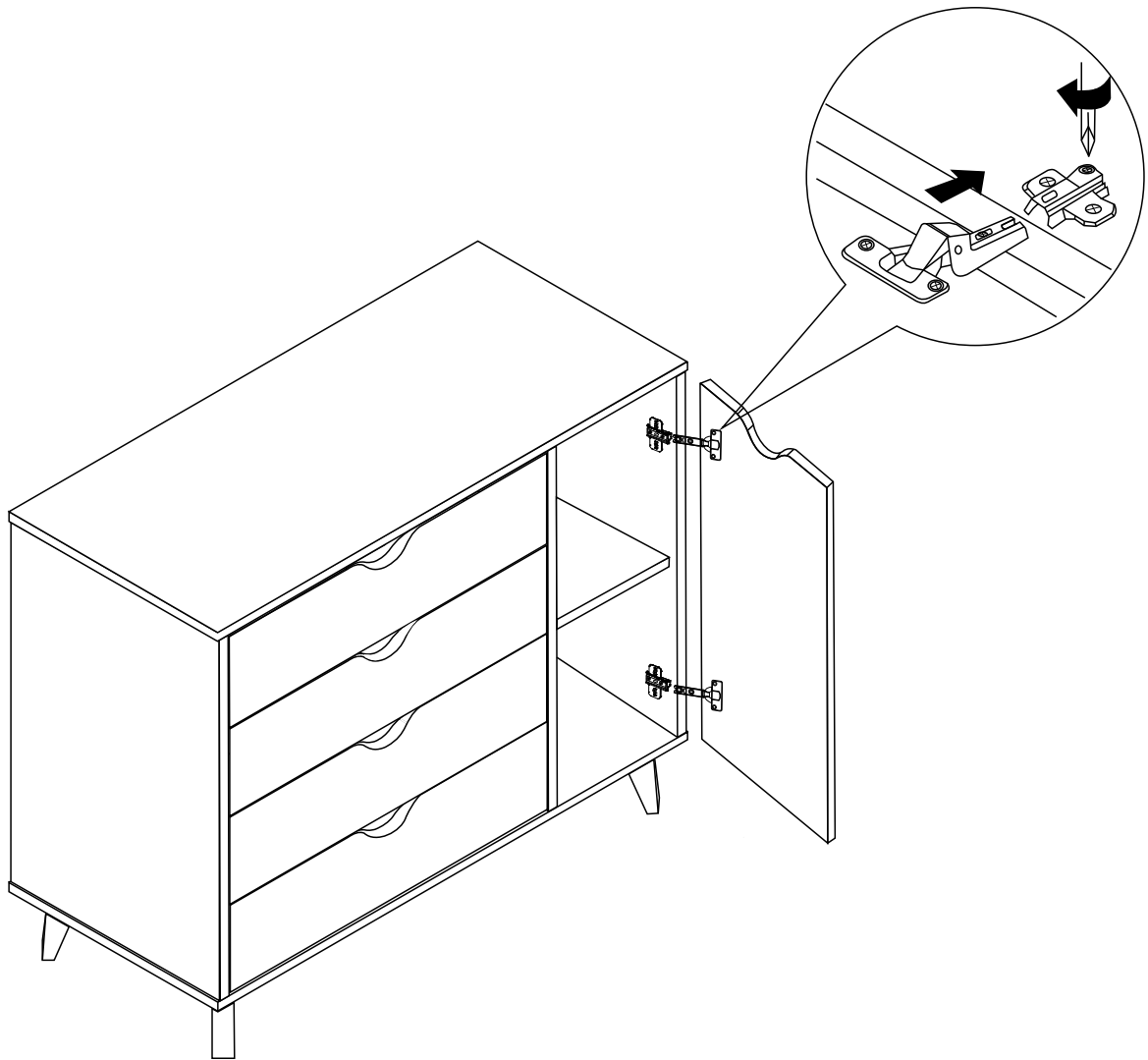

Ajuste de altura
Height adjustment
Ajuste de altura

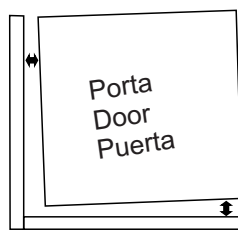

Ajuste interno
Internal adjustment
Ajuste interno

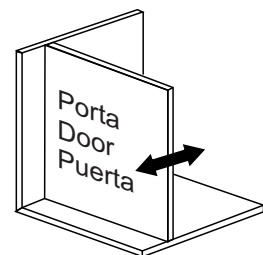

Ajuste de profundidade
Depth adjustment
Ajuste de profundidad

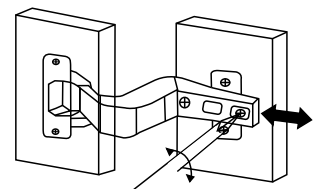
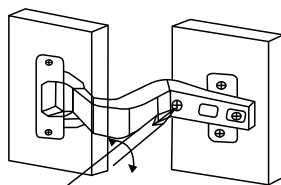
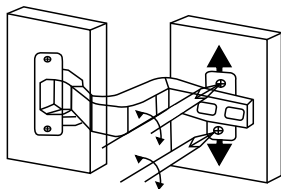

11

Finalizado
Finished
Acabado





Ferimentos por esmagamentos graves ou fatais podem ocorrer com a queda do móvel.

Para reduzir o risco de tombamento de móveis:

- SEMPRE instale o sistema de antitombamento fornecido.
- NUNCA instale uma TV sobre esse produto.
- NUNCA permita que crianças fiquem em pé, subam ou se pendurem em gavetas, portas ou prateleiras.
- NUNCA abra mais de uma gaveta ao mesmo tempo.
- Coloque os objetos mais pesados nas gavetas inferiores.
-

Informação permanente.
Não remova!



Serious or fatal crushing injuries can occur from the tipover.

To reduce the risk of furniture tipover:

- ALWAYS install tipover restraint provided.
- NEVER put a TV on this product.
- NEVER allow children to stand, climb or hang on drawers, doors or shelves.
- NEVER open more than one drawer at a time.
- Place heaviest items in the lowest drawers.

This is a permanent label.
Do not remove!



Riesgo de aplastamiento graves o fatales en caso de caídas de los muebles.

Para reducir el riesgo de que los muebles se vuelquen:

- Instale siempre el sistema antivuelco proporcionado.
- NUNCA instale una TELE en este producto.
- NUNCA permita que los niños se paren, trepen o cuelguen de cajones, puertas o estantes.
- NUNCA abra más de un cajón al mismo tiempo.
- Coloque los objetos más pesados en los cajones inferiores.

Información permanente.
¡No retires!