

ASSEMBLY INSTRUCTIONS

KING BED F1750-13/14/15

Caution: Please read instructions thoroughly before unpacking assembly parts. Sharp exposed staple tips can cause injury, therefore, for your protection, please remove any exposed staples used in packing.

- 1 We recommend that you should assemble this product with the assistance of another person; this will make assembly easier, and will help to eliminate damage to the product or injury to persons during assembly
- 2 Be sure to check all packing materials carefully for small parts that may have come loose inside the carton during shipment.
- 3 Please do not over-tighten screws or bolts
- 4 Please put all parts on a non-abrasive floor before assembly, and follow the assembly steps to assemble your newly purchased product correctly and efficiently



Hardware List For Headboard - F 1750-13			
1		Bolt (Ø5/16" x 50mm)	8 Pcs
2		Spring washer (Ø5/16"x13x1.2)	8 Pcs
3		Flat washer (Ø5/16"x19x2)	8 Pcs
4		Allen Key M4 x L100 mm	1 Pc
Hardware List For Rails F 1750-15			
5		Full Thread Bolt (Ø5/16"x80)	8 Pcs
6		Corved Washer (Ø5/16")	8 Pcs
7		NUT washer (Ø5/16")	8 Pcs
8		Wrench key 1/2"x90mm	1 Pc

Hardware For Footboard F 1750-14			
9		Wood Screw Ø4x25	8 Pcs

Tool Required: Please use a screwdriver for the screwdriver is not included

PARTS LIST - LISTA DE PARTES

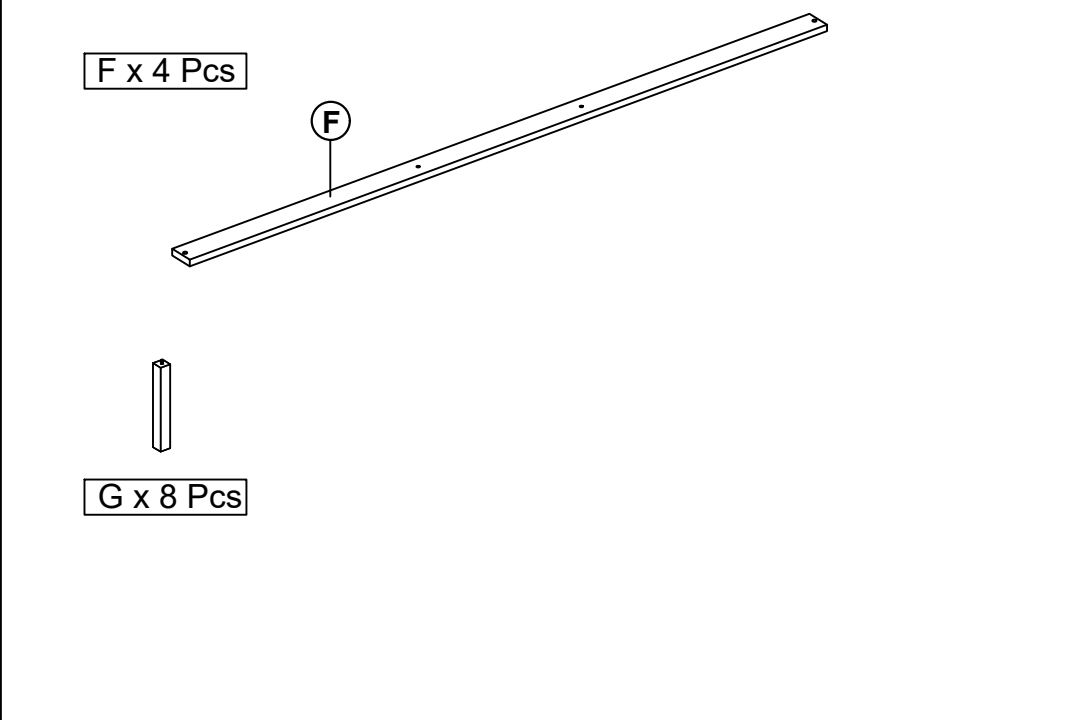
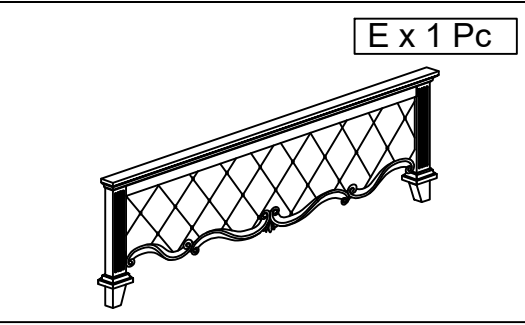
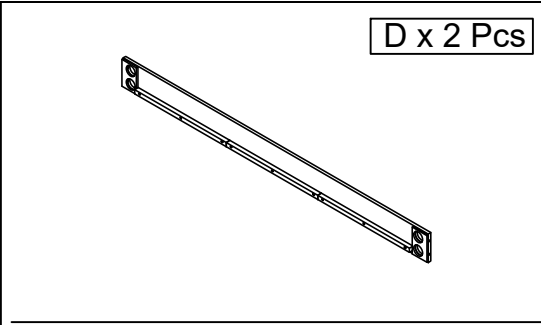
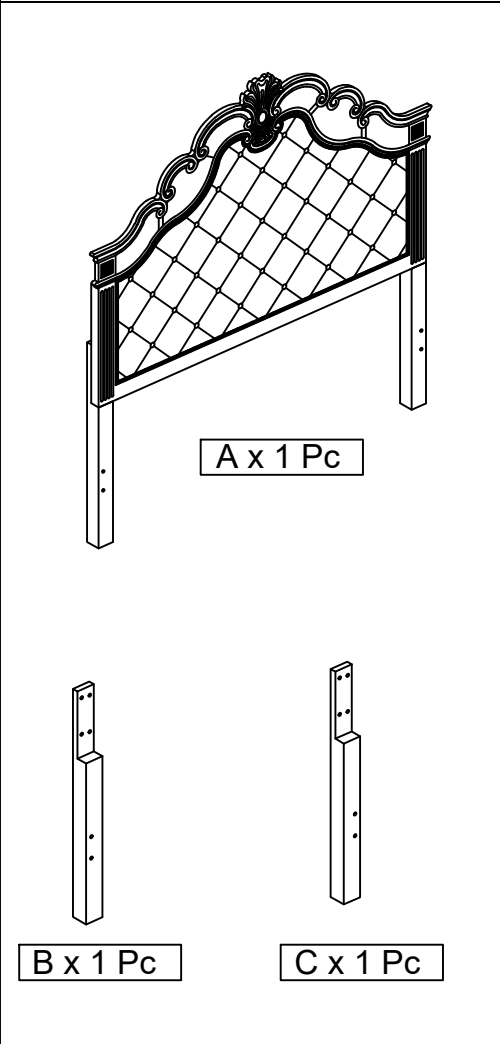

ASSEMBLY INSTRUCTIONS

KING BED F1750-13/14/15

STEP 1

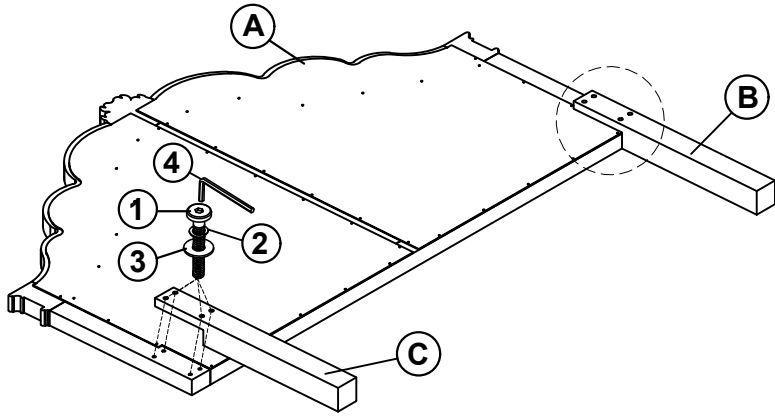

STEP 2

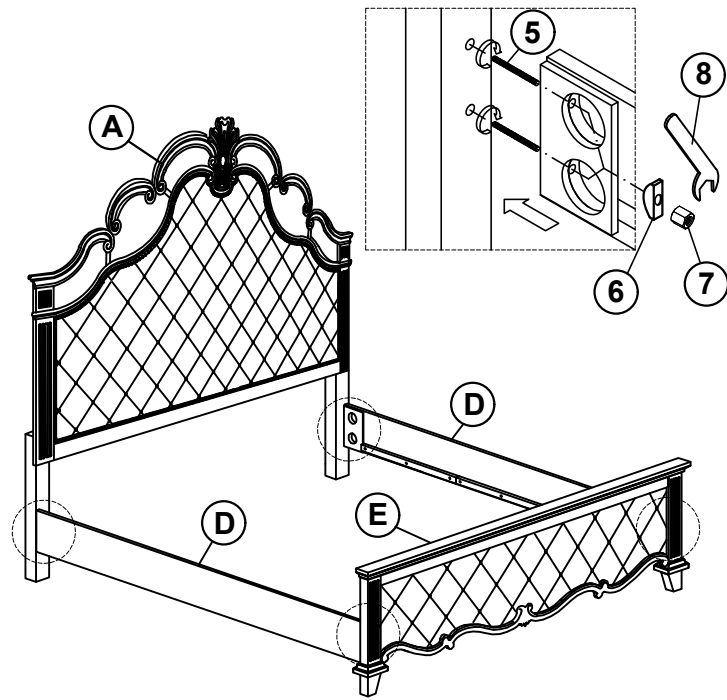

STEP 3

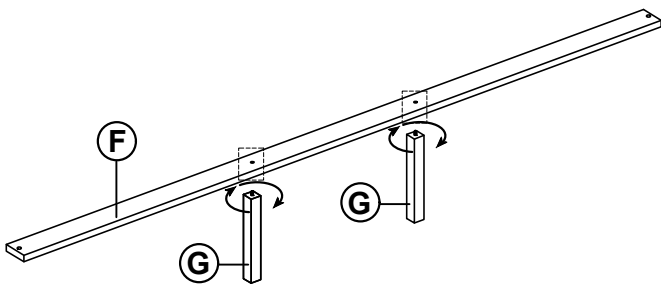

STEP 4

